

TECHNICAL MANUAL

**OPERATOR'S, ORGANIZATIONAL, DIRECT
SUPPORT, AND GENERAL SUPPORT
MAINTENANCE MANUAL INCLUDING
REPAIR PARTS AND SPECIAL TOOLS LISTS
FOR
SPECTRUM ANALYZER RF SECTION PL-1399/U
(NSN 6625-00-432-5055)
(HEWLETT - PACKARD MODEL 8553B)**

**H E A D Q U A R T E R S , D E P A R T M E N T O F T H E A R M Y
27 NOVEMBER 1981**



5

SAFETY STEPS TO FOLLOW IF SOMEONE IS THE VICTIM OF ELECTRICAL SHOCK

1

DO NOT TRY TO PULL OR GRAB THE INDIVIDUAL

2

IF POSSIBLE, TURN OFF THE ELECTRICAL POWER

3

IF YOU CANNOT TURN OFF THE ELECTRICAL POWER, PULL, PUSH, OR LIFT THE PERSON TO SAFETY USING A DRY WOODEN POLE OR A DRY ROPE OR SOME OTHER INSULATING MATERIAL

4

SEND FOR HELP AS SOON AS POSSIBLE

5

AFTER THE INJURED PERSON IS FREE OF CONTACT WITH THE SOURCE OF ELECTRICAL SHOCK, MOVE THE PERSON A SHORT DISTANCE AWAY AND IMMEDIATELY START ARTIFICIAL RESUSCITATION

WARNINGS

The **WARNING** sign denotes a hazard. It calls attention to procedure, practice, or the like, which, if not correctly performed or adhered to, could result in injury or loss of life. Do not proceed beyond a **WARNING** sign until the indicated conditions are fully understood and met.

If this instrument is to be energized through an auto-transformer (for voltage reduction), make sure the common terminal is connected to the earthed pole of the power source.

BEFORE SWITCHING ON THE INSTRUMENT, the protective earth terminal of the instrument must be connected to the protective conductor of the (mains) power cord. The mains plug shall only be inserted in a socket outlet provided with protective earth contact. The protection action must not be negated by using an extension cord (power cable) without a protective grounding conductor. Grounding one conductor of a two-conductor outlet is not sufficient protection.

Any interruption of the protective (grounding) conductor, inside or outside the instrument, or disconnection of the protective earth terminal is likely to make this instrument dangerous. Intentional interruption of the earth ground is prohibited. Whenever it is likely that the protection has been impaired, the instrument must be secured against unintended operation.

Servicing this instrument often requires that you work with the instrument's protective covers removed and with ac power connected. Be very careful; the energy at many points in the instrument may, if contacted, cause personal injury.

Adequate ventilation should be provided while using **TRICHLOROTRIFLUOROETHANE**. Prolonged breathing of vapor should be avoided. The solvent should not be used near heat or open flame; the products of decomposition are toxic and irritating. Since **TRICHLOROTRIFLUOROETHANE** dissolves natural oils, prolonged contact with skin should be avoided. When necessary, use gloves which the solvent cannot penetrate. If the solvent is taken internally, consult a physician immediately.

This manual contains copyrighted material reproduced by permission of the Hewlett-Packard Company. All rights reserved.

TECHNICAL MANUAL }
 No. 11-6625-2781-14&P-2 }

HEADQUARTERS
 DEPARTMENT OF THE ARMY
 WASHINGTON, DC, 27 November 1981

**OPERATOR'S, ORGANIZATIONAL, DIRECT SUPPORT
 AND GENERAL SUPPORT MAINTENANCE MANUAL
 INCLUDING REPAIR PARTS AND SPECIAL TOOLS LIST
 FOR
 SPECTRUM ANALYZER RF SECTION PL-1399/U
 (NSN 625-0-432-5055)**

REPORTING ERRORS AND RECOMMENDING IMPROVEMENTS
 You can help improve this manual. If you find any mistakes or if you know of a way to improve the procedures, please let us know. Mail your letter or DA Form 2028 (Recommended Changes to Publications and Blank Forms), directly to Commander, US Army Communications-Electronics Command, ATTN: DRSEL-ME-MQ, Fort Monmouth, NJ 07703.
 In either case, a reply will be furnished directly to you.

TABLE OF CONTENTS

Section	Page	Page
Section 0	INTRODUCTION	
0-1	Scope	0-1
0-2	Indexes of Publications.....	0-1
0-3	Maintenance Forms, Records and Reports.....	0-1
0-4	Reporting Equipment Improvement Recommendations.....	0-1
0-5	Administrative Storage.....	0-2
0-6	Destruction of Army Electronics Material.....	0-2
Section I	GENERAL INFORMATION.....	1-1
1-1.	Introduction.....	1-1
1-5.	Instruments Covered by Manual.....	1-1
1-7.	Description.....	1-1
1-11.	Options.....	1-1
1-13.	Equipment Required but not Supplied.....	1-2
1-17.	Optional Equipment.....	1-2
1-24.	Test Equipment Required.....	1-2
1-26.	Warranty.....	1-2
Section II	INSTALLATION.....	2-1
2-1.	Shipping Information.....	2-1
2-3.	Initial Inspection.....	2-1
2-4.	Mechanical Check.....	2-1
2-6.	Performance Checkout.....	2-1
2-8.	Deleted.....	2-1
2-10.	Power Requirements.....	2-1
2-11.	Source Power.....	2-1
2-13.	Preliminary Power Settings.....	2-1
2-15.	Power Cable.....	2-1
2-17.	Connections.....	2-1
2-20.	Installation Checkout.....	2-2
Section III	OPERATION.....	3-1
3-1.	Introduction.....	3-1
3-3.	Controls, Indicators and Connectors.....	3-1
3-5.	Operator's Checks.....	3-1
3-7.	Operating Considerations.....	3-1
3-8.	Control Grouping.....	3-1
3-17.	Variable Persistence and Storage Functions.....	3-2
3-22.	Photographic Techniques.....	3-2
3-24.	Applications of Spectrum Analysis.....	3-2
Section IV	PERFORMANCE TESTS.....	4-1
4-1.	Introduction.....	4-1
4-5.	Front Panel Checks.....	4-1
4-7.	Performance Tests.....	4-1
4-12.	Front Panel Check Procedure.....	4-1
4-13.	Preset Adjustments.....	4-1
4-16.	Display Section Adjustments.....	4-2
4-17.	IF Section Adjustments.....	4-2
4-18.	Ampl Cal Adjustment (RF Section).....	4-4
4-19.	Ampl Cal Check for Linear Sensitivity Accuracy.....	4-4
4-22.	Performance Test Procedures.....	4-6
4-23.	Input Impedance.....	4-6
4-24.	Scan Width Accuracy.....	4-8
4-25.	Tuning Dial Accuracy.....	4-11
4-26.	Frequency Response.....	4-13
4-27.	Average Noise Level.....	4-15
4-28.	Spurious Responses.....	4-16
4-29.	Residual Responses.....	4-18
4-30.	Noise Sidebands.....	4-20
4-31.	Local Oscillator Stability and Residual Frequency Modulation.....	4-21
Section V	ADJUSTMENTS.....	5-1
5-1.	Introduction.....	5-1
5-4.	Equipment Required.....	5-1
5-15.	Factory Selected Components.....	5-2
5-17.	Related Adjustments.....	5-2
5-22.	First Local Oscillator Adjustment.....	5-5
5-23.	Tuning Range Adjustment.....	5-8

This manual is an authentication of the manufacturer's commercial literature which, through usage, has been found to cover the data required to operate and maintain this equipment. Since the manual was not prepared in accordance with military specifications and AR 310-3, the format has not been structured to consider levels of maintenance.

	Page		Page
5-24.	200 MHz IF Bandpass Adjustment.....	5-10	Section VIII SERVICE
5-25.	150 MHz Oscillator Adjustment.....	5-12	8-1. Introduction.....
5-26.	120 MHz Low Pass Filter Check and Adjust- ment.....	5-14	8-3. Line Voltage Requirements.....
5-27.	100 kHz Reference Oscillator Check	5-16	8-5. Maintenance Aids.....
5-28.	APC Sampler Adjustment	5-18	8-7. Test Equipment and Accessories Required
5-29.	APC Search Oscillator Checks	5-20	8-10. Adjustments
5-30.	APC 100kHz Rejection Adjustment.....	5-21	8-12. General Procedures
5-31.	APC Tuning Stabilizer Final Check.....	5-23	8-15. General Service Information
Section VI	REPLACEABLE PARTS	6-1	8-22. Basic Transistor Circuits
Section VII	MANUAL CHANGES.....	7-1	8-34. Standard Diode Circuits
7-1.	Introduction.....	7-1	8-38. Special Types of Semiconductors
7-4.	8553B Option H01/H02.....	7-1	8-44. Repair.....
7-7.	Performance Test Procedure Changes for Op- tion H 10/H 02	7-1	8-53. Switching Information
7-8.	Input Impedance.....	7-1	Appendix
7-9.	Average Noise Level.....	7-1	Appendix A. References.....
7-10.	Spurious Responses	7-3	Appendix B. Difference Data Sheets
7-11.	Residual Responses	7-4	Appendix C. Maintenance Allocation Chart.....
7-12.	Manual Back-Dating.....	7-6	Appendix D. Repair Parts and Special Tools List
			Appendix E. Manual Supplement.....

LIST OF ILLUSTRATIONS

Figure	Title	Page	Figure	Title	Page
1-1.	Model 8553B Spectrum Analyzer RF Section ... with 141T Display Section and 8552A Spec- trum Analyzer IF Section	1-0	5-5.	200 MHz Bandpass Shape Adjustment: CRT Display	5-11
1-2.	Instrument Identification	1-2	5-6.	150 MHz Oscillator Adjustment Test Setup	5-12
1-3.	Typical Resolution	1-5	5-7.	120 MHz Low Pass Filter Adjustment Test Setup.....	5-14
1-4.	Typical Frequency Response	1-5	5-8.	120 MHz Bandpass Shape.....	5-15
1-5.	Typical Dynamic Range.....	1-6	5-9.	100 kHz Reference Oscillator Check Test Set- up	5-16
1-6.	HP 11592 Service Kit Required for Mainte- nance	1-9	5-10.	Reference Oscillator Output Measurement	5-17
1-7.	Test Fixture	1-10	5-11.	APC Sampler Adjustment Test Setup	5-18
2-1.	RF Section and IF Section Interconnections.	2-3	5-12.	APC Sampler Adjustment.....	5-19
3-1.	Spectrum Analyzer Controls, Indicators and Connectors.....	3-3	5-13.	APC Search Oscillator Check Test Setup.....	5-20
3-2.	Operational Adjustments	3-6	5-14.	APC 100 kHz Rejection Adjustment Test Set- up	5-21
3-3.	General Operating Procedures.....	3-8	5-15.	APC Tuning Stabilizer Final Check Test Setup.....	5-23
3-4.	Spectrum Analyzer, Rear Panel Controls and ... Connectors.....	3-10	7-1.	Sensitivity Measurement: CRT Display	7-2
4-1.	30 MHz Calibrator Signal and Harmonics	4-2	7-2.	Intermodulation Distortion Test.....	7-3
4-2.	Vertical Gain Adjustment.....	4-2	7-3.	Residual Response Test: 10 to 110 MHz CRT Display	7-5
4-3.	Input Impedance Accuracy Test: 500 kHz to.... 110 MHz.....	4-6	7-4.	H01/H02 Schematic Changes for Service Sheet 4, Figure 8-31	7-7
4-4.	Input Impedance Accuracy Test: 1 kHz to 500.. kHz.....	7-5		H01/H02 Schematic Changes for Service Sheet 3, Figure 8-26	7-8
4-5.	Scan Width Accuracy Test: 10 MHz/Div.....	4-8	8-1.	8553B A5 Voltage Control Assy Extended for Maintenance	8-2
4-6.	Scan Width Accuracy Measurement.....	4-9	8-2.	8553B Inverted Extension for Maintenance.	8-2
4-7.	Scan Width Accuracy Test: .05 MHz/Div.....	4-9	8-3.	Transistor Operation.....	8-5
4-8.	Tuning Dial Accuracy Test	4-11	8-4.	Examples of Diode and Transistor Marking Methods	8-5
4-9.	Frequency Response Test: 10 MHz ,to 110..... MHz.....	4-13	8-5.	Basic Transistor Circuits	8-6
4-10.	Frequency Response Test: 1 kHz to 10 MHz....	4-14	8-6.	Basic Flip-Flop Circuits	8-7
4-11.	Sensitivity Measurement: CRT Display	4-16	8-7.	Basic One-Shot Multivibrator Circuits.....	8-7
4-12.	Intermodulation Distortion Test.....	4-17		Field Effect Transistor Operation	8-8
4-13.	Residual Response Test: 10 to 110 MHz CRT . Display	4-19	8-9.	Basic Diode Circuits	8-8
4-14.	Noise Sideband Test	4-20	8-10.	Silicon Controlled Rectifier used as a Crowbar.....	8-9
4-15.	Demodulation Sensitivity Measurement	4-21	8-11.	Zener Diode Characteristics	8-9
5-1.	First Local Oscillator Adjustment Test Setup.	5-5	8-12.	Varactor Characteristics	8-9
5-2.	First Local Oscillator Adjustment: CRT Dis- play.....	5-6	8-13.	Dial Restranging Procedure.....	8-11
5-3.	Tuning Range Adjustment Test Setup	5-8	8-14.	Evolution of Straight-Line Switch Presenta- tion	8-12
5-4.	200 MHz IF Bandpass Adjustment Test Setup.	5-10	8-15.	Three Positions of Index Light Selector Wafer.....	8-12

<i>Figure</i>	<i>Title</i>	<i>Page</i>
8-16.	Wafer Switch Presentation Versus Straight-Line Presentation.....	8-13
8-17.	Schematic Diagram Notes.....	8-20
8-18.	8553B Assembly and Adjustment Locations (Top and Bottom View).....	8-21
8-19.	Block Diagram of 8553B RF Section.....	8-23
8-20.	Bandwidth Switch Assembly A1 (08663-60126)	8-24

<i>Figure</i>	<i>Title</i>	<i>Page</i>
8-21.	Scan Width Attenuator Assembly A2 (08553-60125)	8-24
8-22.	Input Attenuation Assembly A3 (08553-6021)	8-24
8-23.	Overall Wiring and Switching Diagram	8-25

ILLUSTRATIONS (Cont'd)

<i>Figure</i>	<i>Page</i>	<i>Figure</i>	<i>Page</i>
8-24.	Input Attenuator Assembly (08553-6021) Component Locations	8-29	
8-25.	120 MHz Low Pass Filter A11 (08553-6001) Component Locations	8-29	
8-26.	RF Input Attenuator Control and 120 MHz Low Pass Filter	8-29	
8-27.	Functional Block Diagram	8-30	
8-28.	200 MHz IF Assembly A9 (08553-6004) Component, Connections and Adjustment Locations	8-31	
8-29.	A9A2 (08553-6002) Component Locations	8-31	
8-30.	A9A3 (08553-6006) Component Locations	8-31	
8-31.	First Converter and 200 MHz IF Amplifier	8-31	
8-32.	200-310 MHz VTO Assembly A7 (08553-6003) Component Locations	8-33	
8-33.	200-310 MHz Voltage Tuned Oscillator	8-33	
8-34.	APC Assembly A6 (08553-6010) Component Locations	8-35	
8-35.	APC A6 (08553-6010) Adjustment Point and Connector Locations	8-35	
8-36.	Automatic Phase Control and Sampler/Amplifier Circuits	8-35	
8-37.	Reference Assembly A8 (08553-60131) Component Locations	8-37	
8-38.	1 MHz Crystal Oscillator, Frequency Divider and APC Compensation Circuits	8-37	
8-39.	Preset Scan A4 (08553-6008) Connectors, Test Point Voltages and Component Locations	8-39	
8-40.	Frequency Range Assembly A13 (08553-60123) Adjustment and Component Locations	8-39	
8-41.	Voltage Control A5 (08553-6007) Adjustments, Test Point and Component Locations	8-39	
8-42.	First LO Tuning Voltage, Marker Generator and Frequency Range Control Circuits	8-39	
8-43.	Simplifier Diagram of Second Converter	8-40	
8-44.	Second Converter A10 (08553-60132) Component and Connector Locations	8-41	
8-45.	Second Converter	8-41	
8-46.	Scan Width Attenuator A2 (08553-60125) Test Component Locations	8-43	
8-47.	Scan Width Voltage Divider Circuits	8-43	
8-48.	Bandwidth Control Circuits for IF Section	8-45	
8-49.	Bandwidth Switch A1 (08553-60126) Test Points	8-47	
8-50.	Analogic Switching Matrix	8-47	
8-51.	RF Section, IF Section, Display Section Interconnections	8-49	

TABLES

<i>Table</i>	<i>Page</i>	<i>Table</i>	<i>Page</i>
1-1.	Specifications	1-3	
1-2.	Supplemental Performance Characteristics	1-5	
1-3.	Test Equipment	1-7	
1-4.	Test Accessories	1-8	
3-1.	Display Calibration Conditions(8553B/8552A)	3-11	
4-1.	Accessories and Test Equipment Required for		
	Performance Tests	4-3	
4-2.	Analyzer Front Panel Checks	4-5	
4-3.	Performance Test Record	4-23	
5-1.	Recommended Test Equipment	5-2	
5-2.	Factory Selected Components	5-4	
5-3.	First Local Oscillator Adjustments	5-7	
5-4.	Check and Adjustment Test Record	5-25	
6-1.	Part Numbers for Assy Exchange Orders	6-1	
6-2.	Reference Designators	6-1	
6-3.	Replaceable Parts	6-2	
6-4.	*Part to NSN Cross Reference	6-15	
7-1.	H01/H02 Changes to Replaceable Parts, Table 6-3	7-6	
7-2.	Back-Dating Serial Numbers	7-6	
7-3.	Back-Dating Changes	7-6	
8-1.	 Test Equipment and Accessories List	8-1	
8-2.	Out-of-Circuit Transistor Testing	8-4	
8-3.	Ohmmeters Used for Transistor Testing	8-4	
8-4.	System Test and Troubleshooting Procedure	8-14	
8-5.	8553B Assembly and Component Locations	8-21	
8-6.	8553B Cable Connections	8-24	
8-7.	8553B Plug and Jack Identification	8-25	

* Part Number - National Stock Number Cross Reference Index

**8553B
SPECTRUM ANALYZER
RF SECTION**

SERIAL NUMBERS

This manual applies directly to instruments with serial numbers prefixed 1215A.

With changes described in Section VII, this manual also applies to instruments with serial numbers prefixed 945-, 972-, 982-, 982A, and 1144A.

For additional important information about serial numbers see INSTRUMENTS COVERED BY MANUAL in Section 1.

OPTIONS H01 AND H02

With changes described in Section VII, this manual also applies to instruments with the 75-ohm input options, H01 and H02.

CERTIFICATION

Hewlett-Packard Company certifies that this product met its published specifications at the time of shipment from the factory. Hewlett-Packard further certifies that its calibration measurements are traceable to the United States National Bureau of Standards, to the extent allowed by the Bureau's calibration facility, and to the calibration facilities of other International Standards Organization members.

WARRANTY

This Hewlett-Packard instrument product is warranted against defects in material and workmanship for a period of one year from date of shipment. During the warranty period, Hewlett-Packard Company will, at its option, either repair or replace products which prove to be defective.

For warranty service or repair, this product must be returned to a service facility designated by HP. Buyer shall prepay shipping charges to HP and HP shall pay shipping charges to return the product to Buyer. However, Buyer shall pay all shipping charges, duties, and taxes for products returned to HP from another country.

HP warrants that its software and firmware designated by HP for use with an instrument will execute its programming instructions when properly installed on the instrument. HP does not warrant that the operation of the instrument, or software, or firmware will be uninterrupted or error free.

LIMITATION OF WARRANTY

The foregoing warranty shall not apply to defects resulting from improper or inadequate maintenance of Buyer, Buyer-supplied software or interfacing, unauthorized modification or misuse, operation outside of the environmental specifications for the product, or improper site preparation or maintenance.

NO OTHER WARRANTY IS EXPRESSED OR IMPLIED. HP SPECIFICALLY DISCLAIMS THE IMPLIED WARRANTIES OR MERCHANTABILITY AND FITNESS FOR A PARTICULAR PURPOSE.

EXCLUSIVE REMEDIES

THE REMEDIES PROVIDED HEREIN ARE BUYER'S SOLE AND EXCLUSIVE REMEDIES. HP SHALL NOT BE LIABLE FOR ANY DIRECT, INDIRECT, SPECIAL, INCIDENTAL OR CONSEQUENTIAL DAMAGES, WHETHER BASED ON CONTRACT, TORT, OR ANY OTHER LEGAL THEORY.

SECTION 0

INTRODUCTION

0-1. Scope

This manual describes the PL-1399/U Spectrum Analyzer. It includes technical data, installation, operation and maintenance instructions. The PL-1399/U is referred to throughout this manual as the Hewlett-Packard Model 8553B.

0-2. Indexes of Publications

Refer to the latest issue of the DA Pam 310-4 to determine if there are any new editions, changes, additional publications or modification work orders pertaining to the equipment.

0-3. Maintenance Forms, Records and Reports

a. Reports of Maintenance and Unsatisfactory Equipment. Department of the Army forms and procedures used for equipment maintenance will be those prescribed by TM 38-750, The Army Maintenance Management System.

b. Report of Packaging and Handling Discrepancies. Fill out and forward SF-364 (Report of Discrepancy (ROD)) as prescribed in AR 735-11-2/DLAR 4140.55/NAVMATINST 4355.73/AFR 400.54/MCO 4430.3E.

c. Discrepancy in Shipment Report (DISREP) (SF361). Fill out and forward Discrepancy in Shipment Report (DISREP) (SF-361) as prescribed in AR 55-38/NAVSUPINST 4610.33BIAFR 75-18/MCO P4610.19C/DLAR 4500.15.

0-4. Reporting Equipment Improvement Recommendations (EIR)

If your 8853B Plug-In needs improvement, let us know. Send us an EIR. You, the user, are the only one who can tell us what you don't like about your equipment. Let us know why you don't like the design. Tell us why a procedure is hard to perform. Put it on an

SF-368 (Quality Deficiency Report). Mail it to Commander, US Army Communications-Electronics Command, ATTN: DRSEL-ME-MQ, Fort Monmouth, NJ 07703. We'll send you a reply.

0-5. Administrative Storage

The 8853B RF Section can be stored in stockrooms, warehouses or other protected facilities. The equipment should be protected from excessive humidity, sand, dust and chemical contaminants. Before putting the 8853B RF Section in administrative storage, make the following preparations:

a. Complete the performance tests of Section IV, and if necessary, perform adjustments as indicated in Section V to assure that the unit is completely operable.

b. If the original packing material is not available, at least protect the unit with protective plastic or paper wrapping. Place the unit in a carton or box with makeshift protective packing material around it.

c. Store the equipment indoors, protected from the elements. Maintain the equipment at moderate temperatures and humidity.

0-6. Destruction of Army Electronics Materiel

Destruction of Army electronics materiel to prevent enemy use shall be in accordance with TM 750-244-2.

0-7. Warranty Information

The Spectrum Analyzer, PL-1399/U is warranted by Hewlett-Packard for 12 months. Warranty starts on the date found on DA Form 2410 or DA Form 2408-16 in the logbook. Report all defects in material or workmanship to your supervisor, who will take appropriate action.

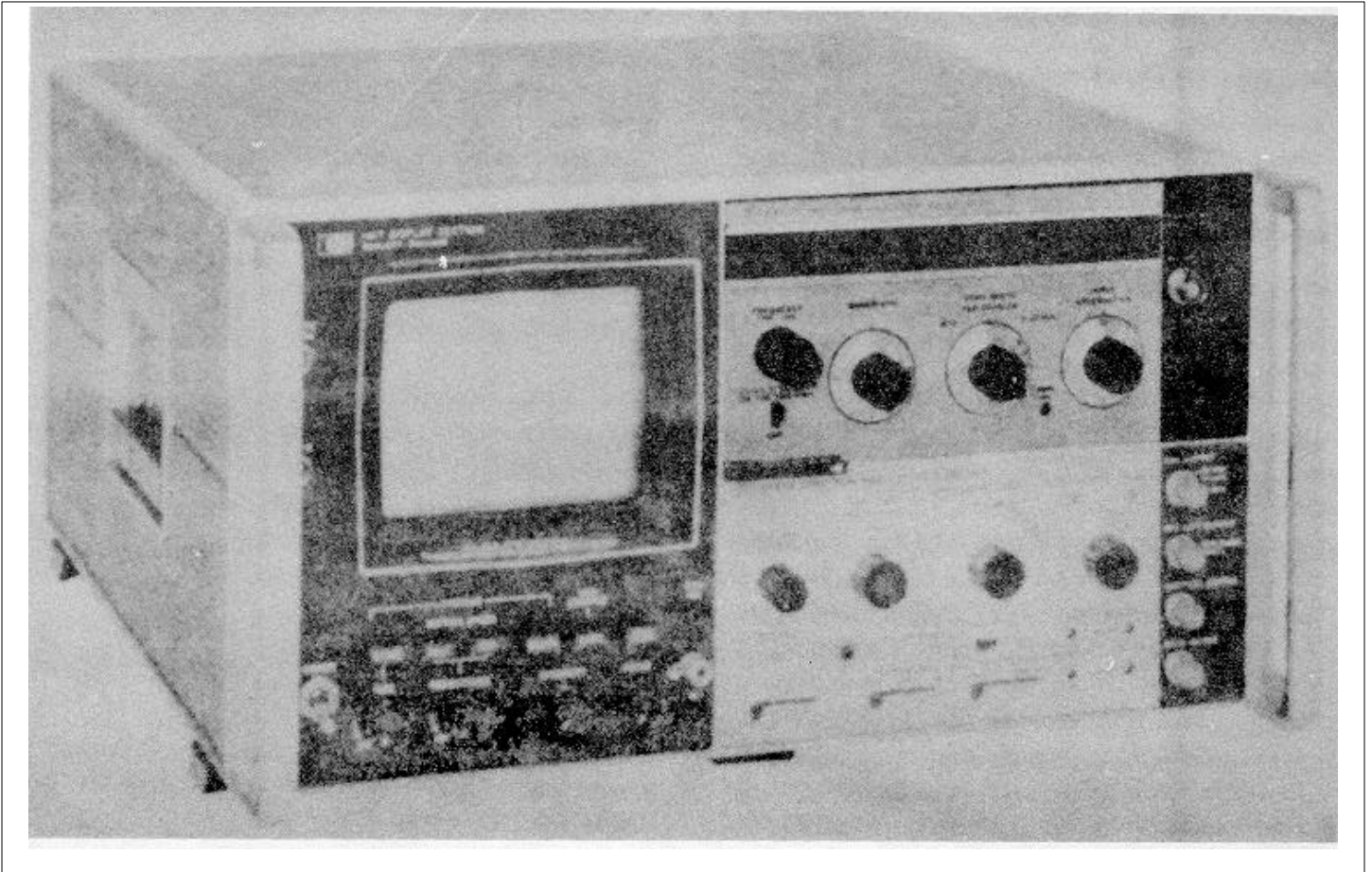

Figure 1-1. Model 8553B Spectrum Analyzer RF Section with 141T Display Section and 8552A Spectrum Analyzer IF Section

Section I**SECTION I****GENERAL INFORMATION****1-1. INTRODUCTION.**

1-2. This manual contains all information required to install, operate, test, adjust and service the Hewlett-Packard Model 8553B Spectrum Analyzer RF Section. This section covers instrument identification, description, options, accessories, specifications and other basic information.

1-3. Figure 1-1 shows the Hewlett-Packard Model 8553B Spectrum Analyzer RF Section with the Model 8552A Spectrum Analyzer IF Section and the Model 141T Display Section.

1-4. The various sections in this manual provide information as follows:

SECTION II, INSTALLATION, provides information relative to incoming inspection, power requirements, mounting, packing and shipping, etc.

SECTION III, OPERATION, provides information relative to operating the equipment.

SECTION IV, PERFORMANCE TESTS, provides information required to ascertain that the instrument is performing in accordance with published specifications.

SECTION V, ADJUSTMENTS, provides information required to properly adjust and align the instrument.

SECTION VI, PARTS LIST, provides ordering information for all replaceable parts and assemblies.

SECTION VII, MANUAL CHANGES, contains information required to adapt this manual to 75 ohm, H01/H02 RF Sections. Also contains manual backdating information.

SECTION VIII, SERVICE, includes information for servicing the instrument.

1-5. INSTRUMENTS COVERED BY MANUAL.

1-6. Hewlett-Packard instruments carry an eight digit serial number (see Figure 1-2) on the back panel. When the serial number prefix on the instrument serial number plate of your instrument is the same as one of

the prefix numbers on the inside title page of this manual, the manual applies directly to the instrument. When the instrument serial number prefix is not listed on the inside title page of initial issue, manual change sheets and manual up-dating information is provided. Later editions or revisions to the manual will contain the required change information in Section VII.

1-7. DESCRIPTION.

1-8. The HP Model 8553B Spectrum Analyzer RF Section is shown in Figure 1-1 with the Model 8552A Spectrum Analyzer IF Section and the Model 141T Display Section. Table 1-1, Specifications, and Table 1-2, Supplemental Performance Characteristics, are for the 8553B RF Section when used with an 8552A IF Section and the 140 Display Section.

1-9. The Analyzer is a highly sensitive super-heterodyne receiver with spectrum scanning capabilities up to 110 MHz. Output video from the receiver circuits is applied to the CRT in the display section; thus, a signal or group of signals can be analyzed in the frequency domain. Input signals are plotted on the CRT as a function of amplitude versus frequency. The amplitude (y-axis) of the CRT is calibrated in absolute units of power (dBm) or voltage ($\mu\text{V}/\text{mV}$); accordingly, absolute and relative measurements of both amplitude and frequency can be made.

1-10. Controls of the instruments are arranged for easy operation. For wide spectrum analysis, the operator can use a preset scan of 0 to 100 MHz. For more detailed study, the spectrum width can be progressively narrowed to .2 kHz, or the scanning capabilities can be eliminated altogether to use the instrument as a fixed frequency receiver. A bandwidth of 300 kHz is automatically selected for preset scan operation; for variable scan and fixed frequency operation, narrower bandwidths can be selected by the operator.

1-11. OPTIONS

1-12. The 8553B/8552 Spectrum Analyzer is available with 75 ohms input/output impedance. The 8553B Option H01 has a Western Electric WE-506A type input connector and the 8553B Option H02 has a BNC input connector. Specifications for the 75 ohm options are listed in Table 1-1 and Section VII lists the changes necessary to adapt this manual to them.

Section I

1-13. EQUIPMENT REQUIRED BUT NOT SUPPLIED

1-14. The 8553B RF Section must be mated with an 8552A or 8552B IF Section and one of the 140 series Display Sections before the units can perform as a spectrum analyzer.

1-15. The 8552A IF Section features calibrated bandwidths, log and linear amplitude calibration and calibrated scan times. The 8552B IF Section has all of the features of the 8552A and, in addition, manual scan, greater frequency stability, narrower bandwidths, and an expanded log scale (2 dB per division).

1-16. The 140S and 140T Display Sections are equipped with a fixed persistence, non-storage CRT; the 141S and 141T Display Sections are equipped with a variable persistence, storage CRT. The 143S Display Section has a large screen (8 x 10 inch) CRT. Overlays are available for the standard 140A and 141A Oscilloscope Mainframes to provide log and linear graticule scales.

1-17. OPTIONAL EQUIPMENT

1-18. The instruments listed below can be used to expand the analyzer's measurement capability. The brief descriptions list some of the features and applications of each instrument. For more information, contact your local Hewlett-Packard Sales and Service Office.

1-19. The 8443A Tracking Generator/Counter is a companion instrument to the 8553B/8552 Spectrum Analyzer. The tracking generator provides a CW signal that precisely tracks the analyzer's tuning frequency. The signal's amplitude is calibrated and can be set, in 0.1 dB increments, from +10 dBm to less than -120 dBm. The counter section of the 8443A applies a marker to the analyzer's CRT and counts the frequency at the marker. The marker can be positioned to measure the frequency, within 10 Hz, of any signal being displayed. The 8443B Tracking Generator is the tracking-generator-only version of the 8443A.

1-20. The 1121A Active Probe may be used to make measurements on sensitive circuits without loading. The

probe power jack on the front panel of the 8553B supplies power for the probe's amplifier. The probe's gain is 1: 1, flat to ±0.5 dB across the full range to 110 MHz, and does not affect the analyzer's absolute amplitude calibration.

1-21. The 8447A Amplifier provides 20 dB of gain, flat ±0.5 dB to 400 MHz, maintaining the analyzer's absolute amplitude calibration. It has noise figure of 5 dB and can be used to improve the sensitivity of the analyzer by 16 dB.

1-22. The 8721A Directional Bridge can be used to make swept VSWR measurements with the analyzer/tracking generator combination.

1-23. The 196B and 197A Oscilloscope Cameras attach directly to the analyzer's CRT bezel and can be used to permanently record any signal displayed on the CRT (see paragraph 3-22).

1-24. TEST EQUIPMENT REQUIRED

1-25. Tables 1-3 and 1-4 list the test equipment and test equipment accessories required to test, adjust and repair the 8553B.

1-26. WARRANTY

1-27. The HP 8553B Spectrum Analyzer RF Section is warranted and certified as indicated on the inner first page.

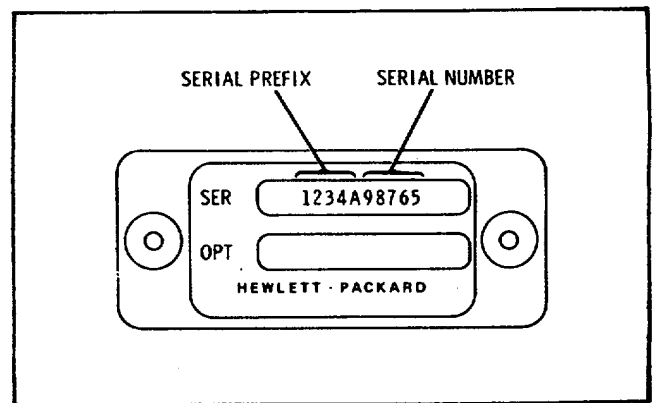

Figure 1-2. Instrument Identification

Section I

Table 1-1. 8553B/8552B Specifications

GENERAL SPECIFICATIONS

¹**Input Impedance:** 50 ohm nominal. Reflection coefficient <0.13 (1.3 SWR), input attenuator ≥10 dB.

¹**Maximum Input Level:** Peak or average power ± 13 dBm (1.4V ac peak), ±50 V dc.

Scan Time: 16 internal scan rates from 0.1 ms/div to 10 sec/div in a 1,2, 5 sequence, or manual scan.

Scan Time Accuracy:
0.1 ms/div to 20ms/div: ±10%
50 ms/div to 10 sec/div: ±20%.

Scan Mode:
Int: Analyzer repetitively scanned by internally generated ramp; synchronization selected by scan trigger.

Single: Single scan with reset actuated by front panel pushbutton.

Ext: Scan determined by 0 to ±8 volt external signal; scan input impedance >10 kΩ,

Blanking: -1.5V external blanking signal required.

Manual: Scan determined by front panel control; continuously variable across CRT in either direction.

Scan Trigger: For Internal Scan Mode, select between:
Auto: Scan free runs.

Line: Scan synchronized with power line frequency.

Ext: Scan synchronized with > 2 volt (20 volt max.) trigger signal (polarity selected by internally located switch in Model 8552B IF Section).

Video: Scan internally synchronized to envelope of RF input signal (signal amplitude of 1.5 major divisions peak-to-peak (required on display section CRT).

Auxiliary Outputs:

Vertical Output: Approximately 0 to --0.8V for 8 division deflection on CRT display; approx. 100 Ω output impedance.

Scan Output: Approx. -5 to ±5V for 10 div CRT deflection, 5 k.Ω output impedance.

Pen Lift Output: 0 to 14V (0V, pen down). Output available in Int and Single Scan modes and Auto, Line, and Video scan trigger.

Power Requirements: 115 or 230 volts ±10%, 50 to 60 Hz, normally less than 225 watts.

Dimensions:

Model 140T or 141T Display Section: 9-1/5 in. high (incl. height of feet) x 163/4 in wide x 18-3/8 in. deep (229 x 425 x 467 mm).

Model 143S Display Section: 21 in. high (incl. height of feet) x 163/4 in. wide x 18-3/8 in. deep (533 x 425 x 467 mm).

Weight:

¹Model 8553B RF Section: Net 12 lb (5,5 kg).

AMPLITUDE SPECIFICATIONS

Absolute Amplitude Calibration Range:

LOG: From -130 to ±10 dBm, 10 dB/div on a 70 dB display; or 2 dB/div on a 16 dB display.

LINEAR: From 0.1 μV/div to 100 mV/div in a 1, 2 sequence on an 8-division display.

¹**Dynamic Range:**

Average Noise Level: <-100 dBm with 10 kHz IF bandwidth.

Spurious Responses: For -40 dBm signal level at the input mixer. 2 Image responses, out-of-band mixing responses, harmonic and intermodulation distortion are all more than 70 dB below the signal level at input mixer 2, 2 MHz to 110 MHz; 60 dB, 1 KHz. to 2 MHz.

Third Order Intermodulation Products: For -40 dBm total signal level at input mixer, 2 third order intermodulation products are more than 70 dB down for input signals of 100 kHz to 110 MHz; signal separation >300 Hz.

¹**Residual Responses:** 200 kHz 100 MHz < -110 dBm, 20 kHz 200 kHz < -95 dBm.

Amplitude Accuracy:

	Log	Linear
¹ Frequency Response (Flatness: attenuator settings ≥10 dB)		
1 kHz to 110 MHz	±0.5 dB	±5.8%
Switching between Bandwidths (at 20°C)		
0.1-300 kHz	± 0.5 dB	± 5.8%
0.03-300 kHz	± 1.0 dB	± 12% ^o
0.01-300 kHz	± 1.5 dB	± 19%
Amplitude Display	±0.25 dB/dB but not more than ± 1.5 dB over the full 70 dB display	±2.8% of full 8 div deflection

Calibrator Output:

Amplitude: -30 dBm, ±0.3 dB.

Frequency: 30 MHz, ±3 kHz.

¹Applies to 8553B

²Signal level at input mixer = Signal level at RF INPUT - INPUT ATTENUATION

Section I

Table 1-1. 8553B/8552B Specifications (cont'd)

FREQUENCY SPECIFICATIONS

¹**Frequency Range:** 1 kHz -110 MHz (0-11 MHz and 0-110 MHz tuning ranges).

¹**Scan Width:** (on 10 division CRT horizontal axis).

Per Division: 18 calibrated scan widths from 10 MHz/div to 20 Hz/div in a 1, 2, 5 sequence.

Preset: 0-100 MHz.

Zero: Analyzer is fixed tuned receiver.

¹**Frequency Accuracy:**

Center Frequency Accuracy: The dial indicates the display center frequency within ± 1 MHz on the 0-110 MHz tuning range; ± 200 kHz on the 0-11 MHz tuning range with FINE TUNE centered, and temperature range of 20 to 30 degrees C.

Scan Width Accuracy: Scan widths 10 MHz/div to 2 MHz/div and 20 kHz/div to 20 Hz/div: Frequency error between two points on the display is less than $\pm 3\%$ of the indicated frequency separation between the two points. Scan widths 1 MHz/div to 50 kHz/div: Frequency error between two points on the display is less than $\pm 10\%$ of the indicated frequency separation.

Resolution:

Bandwidth: IF bandwidths of 10 Hz to 300 kHz provided in a 1, 3 sequence.

Bandwidth Accuracy: Individual IF bandwidth 3 dB points calibrated to $\pm 20\%$ (10 kHz bandwidth $\pm 5\%$).

Bandwidth Selectivity: 60 dB/3 dB IF bandwidth ratios: <11 : 1 for IF bandwidths 10 Hz to 3 kHz, <20 : 1 for IF bandwidths from 10 kHz to 300 kHz, 60 dB points separated by <100 Hz for 10 Hz bandwidth.

¹**Stability:**

Residual FM:

Stabilized: Sidebands >60 dB down 50 Hz or more from CW signal, scan time ≥ 1 sec/div, 10 Hz bandwidth.

Unstabilized: <1 kHz peak-to-peak.

Noise Sidebands: More than 70 dB below CW signal, 50 kHz or more away from signal, with 1 kHz IF bandwidth.

H01/H02 SPECIFICATIONS

NOTE

All specifications for the 75-ohm 8553B/8553B are identical to the 50-ohm 8553B/8552B except for the following.

¹**Input Impedance:** 75 ohms nominal. Reflection Coefficient ≤ 0.13 ($6 \leq 1.30$ SWR, 18 dB return loss).

¹**Maximum Input Level:** Peak or average power to RF Input $< \pm 23$ dBm³ (4V rms, 5.6V peak, ± 50 Vdc).

Absolute Amplitude Calibration Range:

LOG: From -120 to ± 20 dBm, 10 dB/div on a 70 dB display, or 2 dB/div on a 16 dB display.

LINEAR: From 0.2 μ V/div to 200 mV/div in a 1, 2 sequence on an 8-division display.

¹**Dynamic Range:**

Average Noise Level:		Frequency ⁴
IF Bandwidth (kHz)	Avg. Noise Level (dBm) ³	Range (MHz)
1	-110	1-110
10	-100	1-110
100	90	1-110

Spurious Responses:

For -30 dBm Signal Level at Input Mixer:²

Image responses, out-of band mixing responses, harmonic and intermodulation distortion products, and IF feedthrough responses are all more than 70 dB below the Signal Level at Input Mixer. 2 (2 MHz to 110 MHz); 60 dB, 1 kHz to 2 MHz.

Third Order Intermodulation Products:

For -30 dBm Signal Level at Input Mixer 2 third order intermodulation products are more than 70 dB down for input signals of 100 kHz to 110 MHz.

Residual Responses:

(Referred to Signal Level at Input Mixer²):

200 KHz to 110 MHz: < -100 dBm

20 kHz to 200 kHz: < -85 dBm.

Calibrator Output:

Amplitude: -30 dBm³ ± 0.3 dB (8.66 mV into 75 ohms).

NOTE

RF INPUT and CAL OUTPUT connectors: Option H01, equivalent to Western Electric WE-560A; Option H02, standard BNC.

¹Applies to 8553B.

²Signal level at input mixer = Signal level at RF INPUT (10 dB \pm INPUT ATTENUATION).

³0 dBm = 1 mW into 75 ohms.

⁴Typical sensitivity vs. input frequency curves for frequencies from 1 kHz to 1 MHz shown in Figure 1-4 must be derated by 10 dB.

¹Applies to 8553B.

²Signal level at input mixer = Signal level at RF INPUT- INPUT ATTENUATION

Section I

Table 1-2. Supplemental Performance Characteristics

These supplemental Performance Characteristics expand the 8553B/8552B Specifications, describe the instrument's unique features and characteristics, and provide other information useful in applying the instrument.

FREQUENCY CHARACTERISTICS

Frequency Range: For operation of the analyzer outside the 1 kHz to 110 MHz range, see Figure 1-4. Average Noise Level vs. Input Frequency Curve.

Scan Width:

Preset 0 100 MHz: Inverted marker identifies the frequency that becomes the center frequency for SCAN WIDTH PER DIVISION and ZERO scan modes.

Zero: Analyzer becomes fixed-tuned receiver with frequency set by FREQUENCY and FINE TUNE controls and selectable bandwidths set by BANDWIDTH control. Amplitude variations are displayed vs. time on the CRT.

Resolution: See Figure 1-3 for curves of typical 8553B/8552B Spectrum Analyzer resolution using different IF bandwidths.

Stability: First local oscillator can be automatically stabilized (phase-locked) to internal reference for scan widths of 20 kHz/div or less. Signal display shift with stabilization <10 kHz.

Long Term Drift: (At fixed center frequency, after 1 hr. warmup).

Stabilized: 100 Hz/10 min.

Unstabilized: 5 kHz/min; 20 kHz/10 min.

Temperature Drift:

Stabilized: 200 Hz/°C

Unstabilized: 10 kHz/°C.

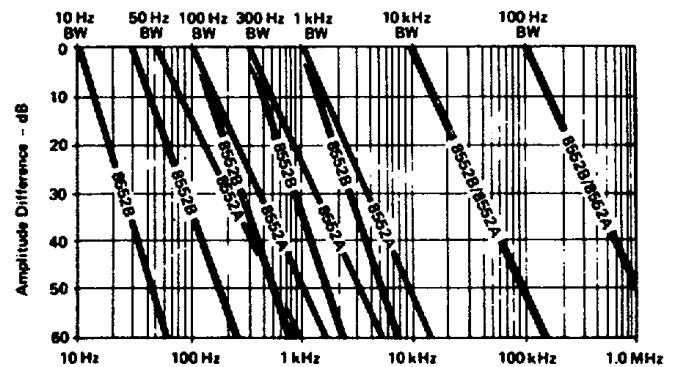

Figure 1-3. Typical Resolution

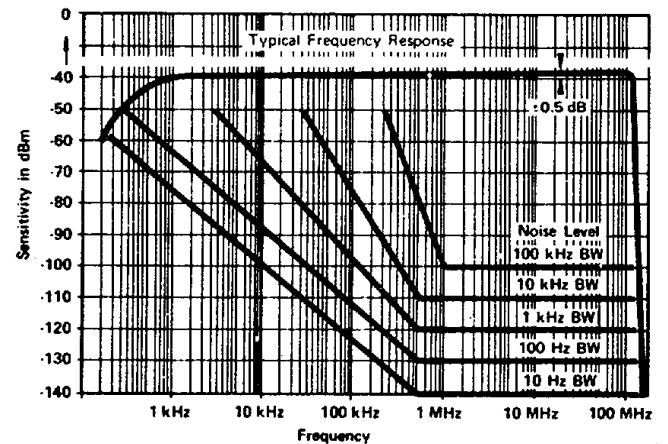

Figure 1-4. Typical Frequency Response

Section I

Table 1-2. Supplemental Performance Characteristics (cont'd)

AMPLITUDE CHARACTERISTICS

The average noise level determines the maximum sensitivity of the analyzer. For typical noise level curves see Figure 1-4.

Dynamic Range: For operation from 200 kHz to 110 MHz with other than -40 dBm inputs, see Figure 1-5.

Gain Compression: For -10 dBm signal level to the input mixer* gain compression <1 dB.

Third Order Intermodulation Products: Typically ≥ 60 dB below input signals separated by ≤ 300 Hz.

Amplitude Accuracy:

Measurement Accuracy: Largely determined by frequency response (± 0.5 dB) and display accuracy (± 1.5 dB) for general use. This ± 2.0 dB can be improved using IF substitution techniques.

Frequency Response (flatness): See Figure 1-4.

Log Reference Level: Controls provide continuous log reference levels from ± 10 dBm to -72 dBm (-2 dBm below 200 kHz).

Log Reference Level Control: Provides 70 dB range (60 dB below 200 kHz), in 10 dB steps. Accurate to ± 0.2 dB ($\pm 2.3\%$, LINEAR SENSITIVITY).

Log Reference Level Vernier: Provides continuous 12 dB range. Accurate to ± 0.1 dB ($\pm 1.2\%$) in 0, -6, and -12 dB positions; otherwise ± 0.25 dB ($\pm 2.8\%$).

Log Reference Level, Switching Between 10 dB/div and 2 dB/div log scales:

Amplitude Accuracy: ± 0.6 dB.

Temperature Stability: ± 0.07 dB/ $^{\circ}$ C.

Amplitude Stability: ± 0.07 dB/ $^{\circ}$ C in Log, ± 0.60 / $^{\circ}$ C in Linear.

Display Uncalibrated Light: Warns if a combination of control settings (IF or video bandwidth; scan width or scan time) degrades the absolute calibration for CW signals.

Video Filter: Averages displayed noise; 10 kHz, 100 Hz, and 10 Hz bandwidths.

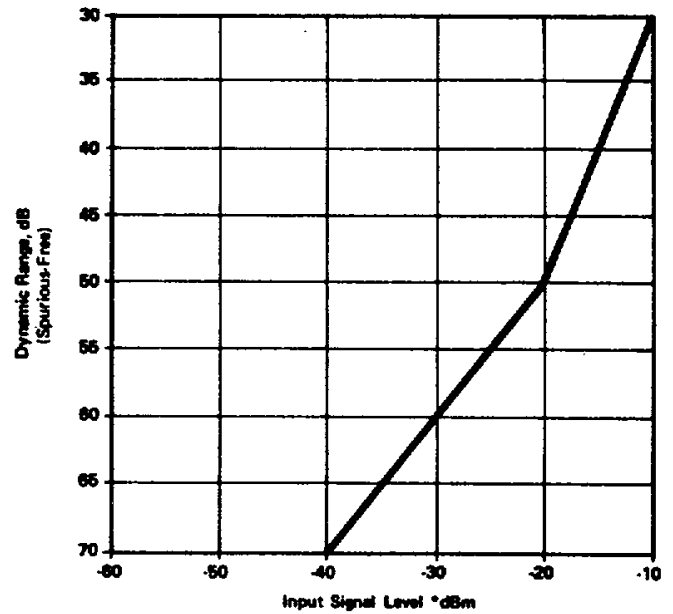

*0 dB Input Attenuation (Input Signal Level = RF Input Level - Input Atten.)

Figure 1-5. Typical Dynamic Range

RF INPUT CHARACTERISTICS

Impedance: 50 ohm nominal, BNC connector: For 75 ohm use matching transformer, such as Anzac TDN-5350.

Reflection Coefficient: When analyzer is tuned to input signal:

$p \leq 6.0.4$ (2.33 SWR) for input attenuation = 0 dB.

$p \leq 0.13$ (1.30 SWR) for input attenuation ≥ 10 dB.

Attenuator: 0 to 50 dB, in 10 dB increments coupled to Log Reference Level indicator automatically maintains absolute calibration.

Attenuator accuracy ± 0.2 dB.

*Signal level at input mixer =
Signal level at RF INPUT - INPUT ATTENUATION

Section I

Table 1-3. Test Equipment

Item	Minimum Specifications or Required Features	Suggested Model
Frequency Comb Generator	Frequency markers spaced 1, 10, 100 MHz apart; usable to 110 MHz Frequency Accuracy: $\pm 0.01\%$ Output Amplitude: > -60 dBm	HP 8406A Comb Generator
Oscillator	Frequency Range: 1 kHz to 10 MHz Output Amplitude: -30 dBm Output Flatness: $\pm 2\%$ from 1 kHz to 10 MHz Output Impedance: 50 ohms	HP 651B Test Oscillator
HF Signal	Generator Frequency Range: 1-50 MHz Output Amplitude: -20 dBm Output Amplitude Accuracy: $\pm 1\%$ Frequency Accuracy: $\pm 1\%$ Output Impedance: 50 ohms	HP 606A/B HF Signal Generator
VHF Signal	Generator Frequency Range: 10-310 MHz Frequency Accuracy: $\pm 1\%$ Output Amplitude: > -20 dBm Output Impedance: 50 ohms	HP 608E/F VHF Signal Generator
Tracking Generator	Frequency Range: 1-110 MHz Output Flatness: ± 0.5 dB over full band Output Impedance: 50 ohms Output Amplitude: at least 0 dBm (Do not substitute.)	HP 8443A Tracking Generator/Counter
AC Voltmeter Voltage	Accuracy: 3% of reading Voltage Range: 30 mV full scale Input Impedance: 10 megohms	HP 400E AC Voltmeter
RF Impedance Meter	Frequency Range: 500 kHz - 108 MHz Accuracy: $\pm 5\%$	HP 4815A RF Vector Impedance Meter with HP 00600A Acces. Kit
Frequency Counter	Frequency Range: 3-310 MHz Accuracy: $\pm 0.001\%$ Sensitivity: 100 mV rms Readout Digits: 7 digits	HP 5245L Frequency Counter with HP 5252A Plug-In
Audio Oscillator	Frequency Range: 50 kHz Output Amplitude: 2 V rms Frequency Accuracy: $\pm 2\%$ Output Impedance: 600 ohms	HP 200 CD Audio Oscillator
Square-Wave Generator	Frequency Range: 10 kHz Output Amplitude: 30V peak into 600 ohms Frequency Accuracy: $\pm 5\%$ Waveform Symmetry: Variable duty cycle Output Impedance: 600 ohms	HP 211B Square-Wave Generator
Power Supply	Output Voltage: Variable, 0-13 Vdc Output Current: 0-40 mA	HP 6217A Power Supply
Amplifier	Frequency Range: 40-60 MHz Amplifier Gain: 40 dB Input and Output Impedance: 50 ohms	HP 461A Amplifier

Section I

Table 1-3. Test Equipment (cont'd)

Item	Minimum Specifications or Required Features	Suggested Model
Tunable RF Voltmeter	Bandwidth: 1 kHz Frequency Range: 1-310 MHz Sensitivity: 10 mV to 1 V rms Input Impedance: >0.1 megohms	HP 8405A Vector Voltmeter
Wave Analyzer	Frequency Range: 90-110 kHz Frequency Accuracy: $\pm 2\%$ Bandwidth: 1000 Hz Voltage Accuracy: $\pm 6\%$ of full scale Input Impedance: >10k Sensitivity: <100 μ V rms	HP 310A Wave Analyzer
Digital Voltmeter	Voltage Accuracy: $\pm 0.2\%$ Voltage Range: 1-50 Vdc full scale Input Impedance: 10 megohms	HP 3440A Digital Voltmeter with HP 3443A Plug-In
Ohmmeter	Resistance Ranges: 10 ohm to 10 megohms Accuracy: $\pm 10\%$ of reading	HP 410C Volt-Ohm-Ammeter
Oscilloscope	Frequency Range: dc to 50 MHz Time Base: 1 μ s/div to 10 ms/div Time Base Accuracy: $\pm 3\%$ Dual Channel, Alternate Operation Ac or dc coupling External Sweep Mode Voltage Accuracy Sensitivity: 0.005 V/div	HP 180A w/ HP 1801A Vertical Amplifier, and HP 1821A Horizontal Amplifier

Table 1-4. Test Accessories

Item	Minimum Specifications or Required Features	Suggested Model
Service Kit	Contents: 140/141 Display Section to Spectrum Analyzer Plug-in Cable Assembly, Test Extender Assembly (HP 11592-60015) IF to RF Section Interconnection Cable Assembly (HP 11592-60016) Selectro Female to BNC Male Test Cable, Three each, 36" long (HP 11592-60001) Selectro Male to Selectro Female Test Cable, Two each, 8" long (HP 11592-60003) Selectro Female to Selectro Female Cable, Two each, 8" long, (HP 11592-60002)	HP 11592A Service Kit

Section I

Table 1-4. Test Accessories (cont'd)

Item	Minimum Specifications or Required Features	Suggested Model
	<p>Extender Board Assembly, 15 pins, 30 conductors, for Plug-in Circuit Boards (HP 11592-60011)</p> <p>Fastener Assembly, 8553B Circuit Board Extender, Two each (HP 11592-20001 and HP 1390-0170)</p> <p>Selectro Jack-to-Jack Adapter (HP 1250-0827)</p> <p>Wrench, open-end, 15/64" (HP 8710-0946)</p> <p>BNC Jack-to-OSM Plug Adapter (HP 1250-1200)</p> <p>OSM Plug-to-Plug Adapter (HP 1250-1158)</p> <p>Cable Assembly, R and P Connector (HP 11592-60013)</p>	

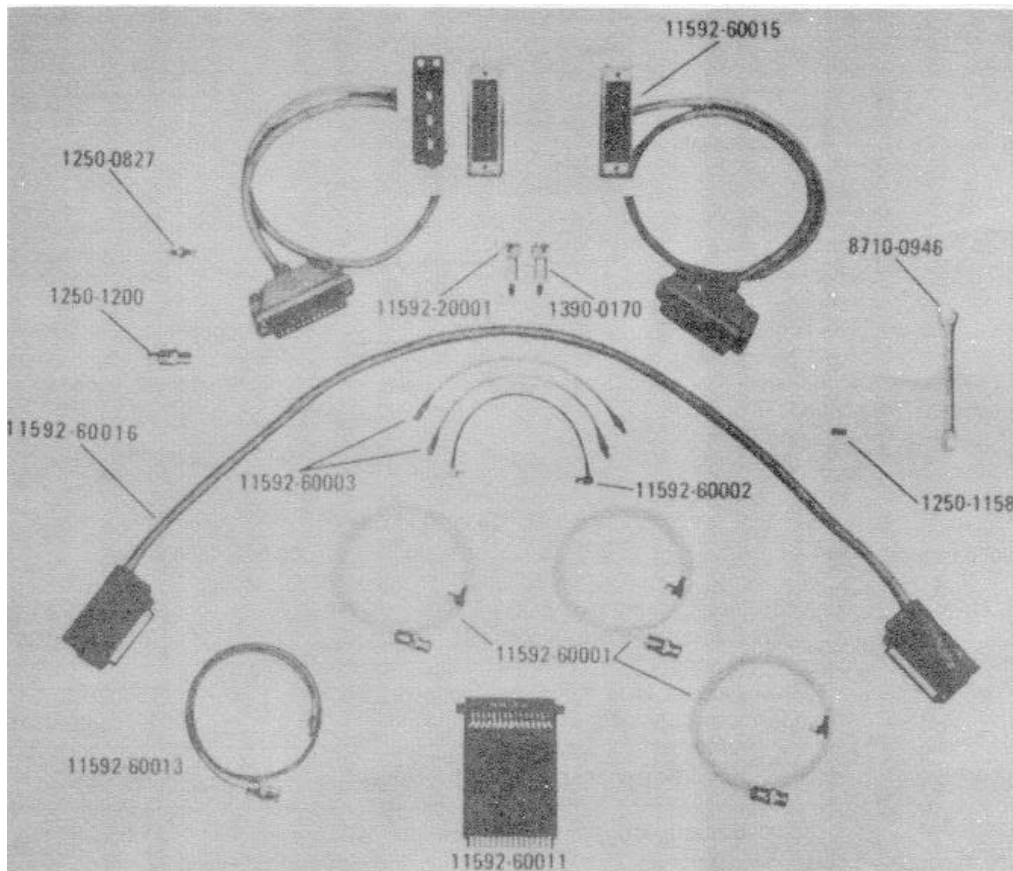
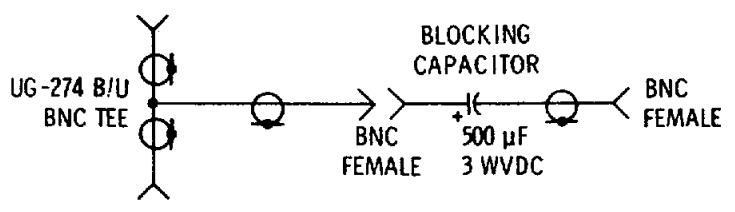

Figure 1-6. HP 11592A Service Kit Required for Maintenance

Section I

Table 1-4. Test Accessories (cont'd)

Item	Minimum Specifications or Required Features	Suggested Model
50-Ohm Tee	Type N female connectors on two ports, with the third port able to accept HP 8405A probe tips.	HP 11536A 50-ohm
10-dB Fixed Attenuator	Attenuation: 10 dB 0.2 dB	HP 8491A, Option 10
50-Ohm Termination	Frequency Range: Dc to 500 MHz VSWR: 1.1 Power Rating: 0.5 Watts Connector: BNC Male	HP 11593A
Three-Port	Mixer Frequency Range: 40-150 MHz Impedance: 50 ohms Connectors: Female BNC on all ports Input Power: 5 mW nominal	HP 10514A Mixer
BNC Tee	Two BNC Female Connectors, one Male BNC Connector	UG-274B/U HP 1250-0781
Adapter	BNC Male to Type N Female	UG-349A/U HP 1250-0077
Adapter	BNC Male to Binding Post	HP 10110A
Adapter (2)	BNC Female to Type N Male	UG-201A/U HP 1250-0780
Test Fixture	<p>Consists of:</p>  <p style="text-align: center;"><i>Figure 1-7. Test Fixture</i></p> <p>Blocking Capacitor 500 μF 3V BNC Female Connectors (2)</p>	<p>HP 0180-1734 HP 1250-0083</p>
Voltage Probe	Dual Banana Plug to Probe Tip and Clip (Ground) Lead	HP 10025A Straight-Through Voltage Probe
Cable Assembly (3)	Male BNC Connectors, 48 inches long	HP 10503A
Cable Assembly	Dual Banana Plug to Clip Leads, 45 in. long	HP 11002A
Cable Assembly	Dual Banana Plug to Dual Banana Plug, 44 in. long	HP 11000A

Section I

Table 1-4. Test Accessories (cont'd)

Item	Minimum Specifications or Required Features	Suggested Model
Cable Assembly	BNC Male to one end only; 44 in. long. (Attach Test Clips to Shield and Center Conductor.)	HP 10501A
Tuning Tool, Blade	Nonmetallic Shaft, 6 inches long	General Cement 5003 HP 8730-0013
Tuning Tool, Slot	Nonmetallic, 5-inch Shaft	Gowanda PC-9668-1 HP 8710-1010
Wrench	Open-end, 15/64 inch	HP 8710-0946
Screwdrivers	Phillips #1; Phillips #2 Pozidriv #1 (Small); Stanley #5331 Pozidriv #2 (Medium); Stanley #5332	HP 8710-0899 HP 8710-0900
Tuning Tool, Slot	Nonmetallic, 2.5 inch shaft	HP 8710-0095
Adapter	Subminiature jack-to-jack adapter	HP 1250-0837
Adapter	BNC Female to sub-miniature Male	HP 1250-0832
Termination	Sub-miniature 50-ohm Termination	HP 1250-0839
Adapter	8405A Probe to Male BNC	HP 10218A
Load Assembly	50-ohm Load Assembly	HP 08553-60122
Cable Assembly	Interconnection cable between Tracking Generator and Spectrum Analyzer	HP 08443-60049

Section II**SECTION II****INSTALLATION****2-1. SHIPPING INFORMATION**

2-2. Since the RF and IF Sections are received separately, the plug-ins must be mechanically fitted together, electrically connected, and inserted in an oscilloscope mainframe of the 140-series. For mechanical and electrical connections, refer to Figure 2-1 and Paragraph 2-17.

2-3. INITIAL INSPECTION**2-4. Mechanical Check**

2-5. If shipping carton is damaged, ask that agent of carrier be present when instrument is unpacked. Inspect instrument for mechanical damage such as scratches, dents, broken knobs, or other defects. Also, check cushioning material for signs of severe stress.

2-6. Performance Checkout

2-7. As soon as possible after receipt, the instrument should be performance-tested in accordance with the Performance Test, Section IV.

2-8. DELETED.**2-10. POWER REQUIREMENTS****2-11. Source Power**

2-12. The Spectrum Analyzer can be operated from a 50 to 60-hertz input line that supplies either 115-volt or 230-volt ($\pm 10\%$ in each case) power. Consumed power varies with the plug-ins used but is normally less than 225 watts.

2-13. Preliminary Power Settings

2-14. The 115/230 power selector switch at rear of display section must be set to agree with the available line voltage that is, if the line voltage is 115 volts, the slide switch must be positioned so that 115 is clearly visible. (The instrument is internally fused for 115-volt operation; if 230-volt power is used, refer to fuse replacement procedures in the display section manual.)

2-15. Power Cable

2-16. To protect operating personnel, the National Electrical Manufacturers' Association (NEMA) recommends that instrument panel and cabinet be grounded. The analyzer is equipped with a three conductor power cable; the third conductor is the ground conductor and, when the cable is plugged into an appropriate receptacle, the instrument is grounded. To preserve the protection feature when operating the instrument from a two-contact-outlet, use a three-prong to two-prong adapter and connect the green lead on the adapter to ground.

2-17. CONNECTIONS

2-18. Since the RF and IF Sections are shipped separately, the plug-ins must be mechanically fitted together, electrically connected, and then inserted into the display section mainframe. To make these connections, refer to Figure 2-1 and proceed as follows:

- a. Set the IF section on a level bench. Locate slot near right rear corner of RF section; also, locate metal tab on IF section that engages with this slot.
- b. Grasp the 8553B RF section near middle of chassis and raise until it is a few inches above the IF section.
- c. Tilt RF section until front of assembly is about 2 inches higher than the rear.
- d. Engage assemblies in such a way that metal tab on the rear of the IF section slips through the slot on RF section.
- e. With the preceding mechanical interface completed, gently lower RF section until electrical plug and receptacle meet.
- f. Position RF section as required to mate the plug and receptacle. When plug and receptacle are properly aligned, only a small downward pressure is required to obtain a snug fit.

Section II

g. After the RF and IF sections are joined mechanically and electrically, the complete assembly is ready to insert in the display section mainframe.

h. Pick up the RF/IF sections and center in opening of display section. Push forward until assembly fits snugly into display section mainframe.

i. Push in front panel latch to securely fasten assembly in place.

2-19. To separate the RF/IF sections from display section and then to separate the RF section from the IF section, proceed as follows:

a. Push front panel latch in direction of arrow until it releases.

b. Firmly grasp the middle part of latch flange and pull RF/IF sections straight out.

c. Locate black press-to-release lever near left front side of RF section. Press this lever and simultaneously exert an upward pulling force on front edge of RF section.

d. When the two sections separate at the front, raise RF section two or three inches and slide metal tab at rear of IF section out of the slot with which it is engaged.

2-20. INSTALLATION CHECKOUT

2-21. After equipping the display mainframe with the plug-in RF/IF sections (Paragraph 2-17), the operation procedures specified in Section III should be performed.

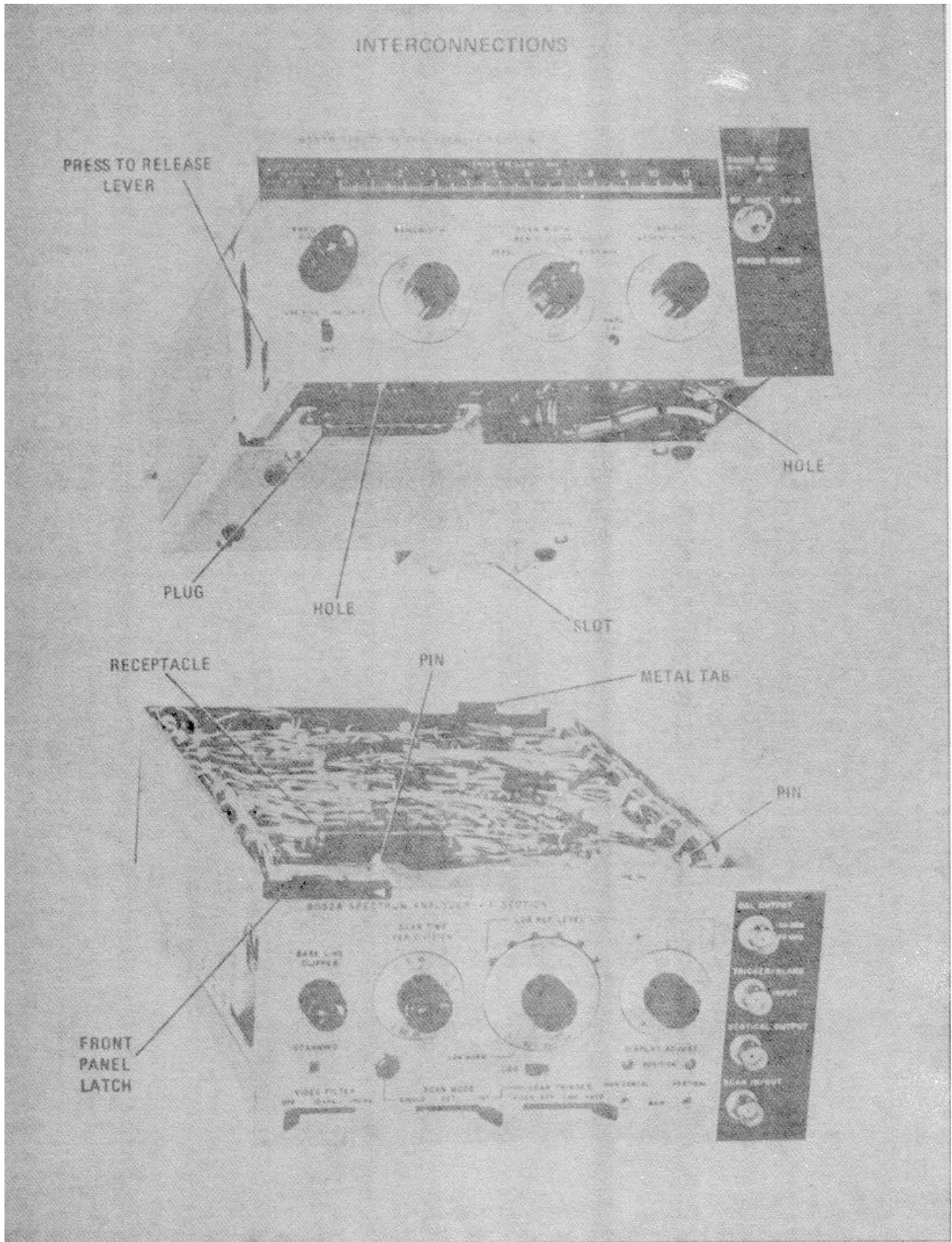

Figure 2-1. RF Section and IF Section Interconnections 2-3/2-4

Section III

**SECTION III
OPERATION**

3-1. INTRODUCTION

3-2. This section provides complete operating instructions for the HP 8553B Spectrum Analyzer RF Section. It also provides a brief description of IF Section and Display Section controls; for a detailed description of these sections, refer to their manuals.

3-3. CONTROLS, INDICATORS AND CONNECTORS

3-4. The RF Section is used with either an 8552A or 8552B IF Section and one of the 140 series display sections. The instruments shown in Figure 3-1 are, respectively, an 8553B RF Section with an 8552A IF Section and a 140T Display Section, and an 8553B RF Section with an 8552B IF Section and a 141T Display Section. The rear panel of the instrument shown in Figures 3-2, 3-3, and 3-4 is the same for either display section.

3-5. OPERATOR'S CHECKS

3-6. Upon receipt of the analyzer, or when one or more sections are changed, perform the operational adjustments listed in Figure 3-2. This procedure corrects for minor differences between units and ensures that the RF section, IF section and display section are properly matched.

3-7. OPERATING CONSIDERATIONS

3-8. Control Grouping

3-9. The analyzer front panel controls fall into three general groups: those that deal with the display, those that deal with frequency, and those that deal with amplitude.

3-10. Display. The display group consists of:

- | | |
|-------------------|---------------|
| SCAN TIME | BASE LINE |
| CLIPPER SCAN MODE | INTENSITY |
| SCAN TRIGGER | FOCUS DISPLAY |
| ADJUST | AMPL CAL |
| VIDEO FILTER | |

In addition, MANUAL SCAN on the 8552B and the variable persistence and storage controls on the 141T (see paragraph 3-17) fall into this category.

3-11. The display group enables the operator to calibrate the display and to select a variety of scan and display conditions. The controls are explained in Figure 3-1. However, there is one analyzer characteristic that an operator should consider when he is using an externally generated scan (and MANUAL SCAN in the 8552B). The DISPLAY UNCAL lamp only responds to the analyzer's control settings, not to the signal itself. So the lamp will not indicate that an external sweep is too fast, causing the display to become uncalibrated.

- 3-12. Frequency.** The frequency group consists of:
- | | |
|------------|------------|
| FREQUENCY | BANDWIDTH |
| FINE TUNE | SCAN WIDTH |
| STABILIZER | RANGE MHZ |

3-13. The frequency group enables the operator to control how the analyzer samples the frequency domain. The SCAN WIDTH controls permit the operator to look at a spectrum that varies in width from 0 100 MHz to ZERO. FREQUENCY and FINE TUNE set the center frequency of the spectrum, and BANDWIDTH controls the resolution of the signals seen on the CRT.

3-14. Amplitude. The amplitude group consists of:

- LOG REF LEVEL · LINEAR SENSITIVITY
- LOG/LINEAR
- INPUT ATTENUATION

3-15. The amplitude group enables the operator to measure signal amplitude in voltage or dBm. INPUT ATTENUATION is used to control the signal level at the analyzer's input mixer.* For minimum distortion and maximum dynamic range, always set it for -40 dBm at the mixer. For example, initially set INPUT ATTENUATION at 20 dB or more (this ensures that any signal that is less than 1V rms is below compression). Then note the highest level signal on the display, and subtract that reading from 40 dB; set INPUT ATTENUATION for the result. (If the signal is about -10 dBm, 40 dB -10 dB = 30 dB; set the attenuator for 30 dB.)

*Signal level at input mixer =
Signal level at RF INPUT - INPUT ATTENUATION

Section III

3-16. If the operator is only interested in measuring amplitude, the signal at the mixer can be as high as -10 dBm. (Signals above this level will compress.)

3-17. Variable Persistence and Storage Functions

3-18. With the 141T Display Section the operator can set trace persistence for a bright, steady trace that does not flicker, even on the slow sweeps required for narrow band analysis. The variable persistence also permits the display of low repetition rate pulses without flickering and, using the longest persistence, intermittent signals can be captured and displayed. The storage capability allows side-by-side comparison of changing signals.

3-19. Persistence and Intensity. These controls largely determine how long a written signal will be visible. Specifically, PERSISTENCE controls the rate at which a signal is erased and INTENSITY controls the trace brightness as the signal is written. With a given PERSISTENCE setting, the actual time of trace visibility can be increased by greater INTENSITY. Since the PERSISTENCE control sets the rate of erasing a written signal, it follows that a brighter trace will require more time to be erased. Conversely, a display of low intensity will disappear more rapidly. The same principle applies to a stored display of high and low intensity.

CAUTION

Excessive INTENSITY will damage the CRT storage mesh. The INTENSITY setting for any sweep speed should just eliminate trace blooming with minimum PERSISTENCE setting.

3-20. Storage. These controls select the storage mode in which the CRT functions. In ERASE, STORE and WRITING SPEED are disconnected and all written signals are removed from the CRT. The STORE selector disconnects the WRITING SPEED and ERASE functions and implements signal retention at reduced intensity. In the STORE mode, PERSISTENCE and INTENSITY have no function.

3-21. Writing Speed. In the FAST mode, the rate of erasing a written display is decreased. Since the erasing rate is decreased, the entire screen becomes

illuminated more rapidly and the display is obscured. The effective persistence and storage time are thus considerably reduced.

3-22. Photographic Techniques

3-23. Excellent oscillographic photography is possible when the Spectrum Analyzer is used with proper optics and when proper techniques are employed. Both the HP 196B and the 197A Oscilloscope Cameras attach directly to the analyzer's CRT bezel without adapters. Both cameras also have an Ultra-Violet light source that causes a uniform glow of the CRT phosphor. This gives the finished photograph a gray background that contrasts sharply with the white trace and the black graticule lines. Ultra-Violet illumination is normally used only when the CRT is of the non-storage and fixed persistence type (140T Display Section). For a storage or variable persistence CRT (141T Display Section), a uniform gray background is obtained by simply taking the photograph in STORE rather than in VIEW.

3-24. APPLICATIONS OF SPECTRUM ANALYSIS

3-25. Signal analysis in the frequency domain is recognized as a tremendous aid in the evaluation of circuits and systems. Frequency-domain techniques are logical, easy to use, and the results are easy to interpret. Some of the more important frequency domain phenomena are: spectral purity and distortion of oscillators, frequency response, parasitic oscillations, and distortion characteristics of amplifiers, frequency parameters of networks and filters, and all types of modulation.

3-26. The Spectrum Analyzer is capable of analytically resolving almost any problem whose unknowns are amplitude and frequency; thus, over and above the general-purpose applications, the instrument is a powerful observation-and-measurement tool for surveillance, EMC, and systems work. To define each instrument application is beyond the scope of this manual. For further details, there is a complete discussion of Spectrum Analyzer applications in Application Note 63A-D. These application notes are available from the nearest HP Sales and Service Office.

Section III

NOTE

See foldout on page 3-5 illustration.

1. Display Screen with Graticule.
 - a. LINear calibration (read from bottom to top of screen).
 - b. LOGarithmic calibration (read from top LOG REF line towards bottom of screen).
 - c. Amplitude calibration reference. (Refer to Items 15 and 26.)
 - d. Center frequency of selected scan width.
 - e. Relative frequencies with respect to center frequency.
2. Lights when relationship between scan time, scan width, bandwidth, and video filtering is such that accuracy of vertical calibration is impaired.
3. Coarse-tunes analyzer center frequency.
4. Fine-tunes analyzer center frequency.
5. In TUNING STABILIZER position, first LO is automatically phase-locked to a reference crystal harmonic for scan widths of 20kHz/DIV and less.
6. Selects 3-db IF bandwidths.
7. Indicates center frequency to which instrument is tuned.
8. Indicates per-division scan width.
9. Selects 0-100 MHz full-spectrum "preset" scan, PER DIVISION SCAN as determined by setting of outer dial (8), or "fixed-frequency" receiver in ZERO scan position.
10. RF amplitude gain calibration.
11. Attenuates input signal in 110-dB steps and lights one index lamp (15) for each of its six positions. The left index lamp lights for 0 (zero) attenuation. The lighted lamp and steps-in attenuation then progress in clockwise order; thus, absolute amplitude calibration is preserved.
12. Controls the tuning range of the FREQUENCY control. In 0-11 MHz position tuning range of the FREQUENCY control is limited to 11 MHz.
13. In 0-110 MHz position, tuning range of FREQUENCY control is extended to 110 MHz.
14. 50-Ohm coaxial input connector.
15. Supplies power to active probe.
16. With LOG/Linear switch (25) set to LOG, lighted index lamp refers matching dB graduation to top LOG REF line of graticule; for example, if -30dBm and so serves as an absolute amplitude reference. With LOG/LINEAR switch set to LIENEAR, lighted index lamp indicates the matching voltage graduation to be used as a per-division multiplier for calibrated voltage readings. (blue marking).
17. Provides a 30-MHz signal at -30dBm for amplitude calibration of spectrum analyzer.

CAUTION

To prevent mixer burnout, attenuator damage, or both, the RF INPUT level should never exceed 1.4 Vac peak or ± 50 Vdc.

17. Provides penlift operation to HP 7005, 7035, 7004, 7034 and all new TTL compatible HP recorders. Provides a banking input for external scan mode operation. Provides an input for external trigger operation.
18. Detected video output proportional to vertical deflection on CRT.
19. For receiving an external scan ramp or output coupling for the internally-generated scan ramp. Input or output function determined by INT/EXT positions of SCAN MODE switch.
20. Plus "+" lights when logarithmic amplification (25) is selected; times "x" lights when linear amplification (25) is selected. With "+" lighted, LOG REF lines (1c) is sum (black numerals) of LOG REF LEVEL controls. With "x" lighted,

Figure 3-1. Spectrum Analyzer Controls, Indicators and Connectors

Section III

per division absolute voltage amplitude (1a) is product (blue numerals) of LINEAR SENSITIVITY controls.

21. Adjusts vertical position and gain of trace.
22. Adjusts horizontal position and gain of trace.
23. Indicates 1-dB increments for logarithmic amplification; indicates multiplication factors up to unity for linear amplification.
24. Selects scan trigger mode.
25. Selects logarithmic or linear display mode.
26. Assuming that dB graduation (black numerals) matches position of lighted index lamp, LOG REF graticule line indicates power level when LOG/LINEAR (25) is set to LOG. With LOG/LINEAR set to LINEAR, indicates per division multiplier for calibrated voltage amplitude for whatever voltage graduation (blue numerals) matches position of lighted index lamp.
27. Selects scan ramp mode. Ramp is internally generated for SINGLE/INT positions but it must be externally supplied for EXT position. (Refer to Item 19).
28. Press to initiate scan with SCAN MODE switch set to SINGLE; press during scan to stop and reset scan.
29. Controls SCAN TIME.
30. May select 100 Hz, 10 kHz or OFF position of low-pass filter for detected video.
31. Lights for duration of each scan for SINGLE and INT scan modes.
32. Blanks lower part of trace to prevent overexposure of photographs (due to high

intensity baseline). Blanking function also prevents blooming with a variable-persistence/storage display section.

33. Provides 1- and 10-volt, peak-to-peak, 60 Hz squarewave outputs.

CAUTION

These calibrated outputs must never be used with the spectrum analyzer. (These outputs are for use only with the 1400-series oscilloscope plug-ins).

34. Makes base line parallel with the horizontal graticule line.
35. Adjusts brightness of CRT display.

CAUTION

Excessive brightness for a static or very slow moving trace may burn the phosphor and permanently damage the CRT. This caution is applicable to both the fixed and variable persistence/storage CRT; however, the latter is especially vulnerable to operational errors of this type.

36. Used with FOCUS control (37) to obtain smallest spot with maximum roundness.
37. Focuses CRT beam.
38. Lights when line voltage is applied and instrument is turned on.
39. Switches line voltage to instrument.
40. When used with 1400-series oscilloscope plug-ins, intensifies and returns beam to CRT, regardless of deflection potentials. When used with 8550 series plug-ins, the beam finder has no function.

41. Selects non-storage function.

8552B ONLY

CAUTION

Use storage function when possible to prevent damage to the CRT.

42. Press to ERASE when in STD or FAST writing speed.

43. Selects writing speed.

44. Varies time the trace is visible.

45. Selects storage time.

46. Press to store signal display. Storage time (relative display brightness) in storage mode is adjusted by Item 45.

47. Controls scan in MAN position of SCAN MODE (27).

48. Selects LINEAR, 10 dB LOG or 2 dB LOG display modes. To use 2 dB LOG, first find signal using 10 dB LOG; display desired portion in top 16 dB of screen, then switch to 2 dB LOG. Top of screen (LOG REF) remains the same; -70 dB line is now -14 dB (each major division is 2 dB).

NOTE

Do NOT make any VERTICAL GAIN or POSITION adjustments in the 2 dB LOG mode as the front panel calibration will become invalid.

Figure 3-1. Spectrum Analyzer Controls, Indicators and Connectors (cont'd)

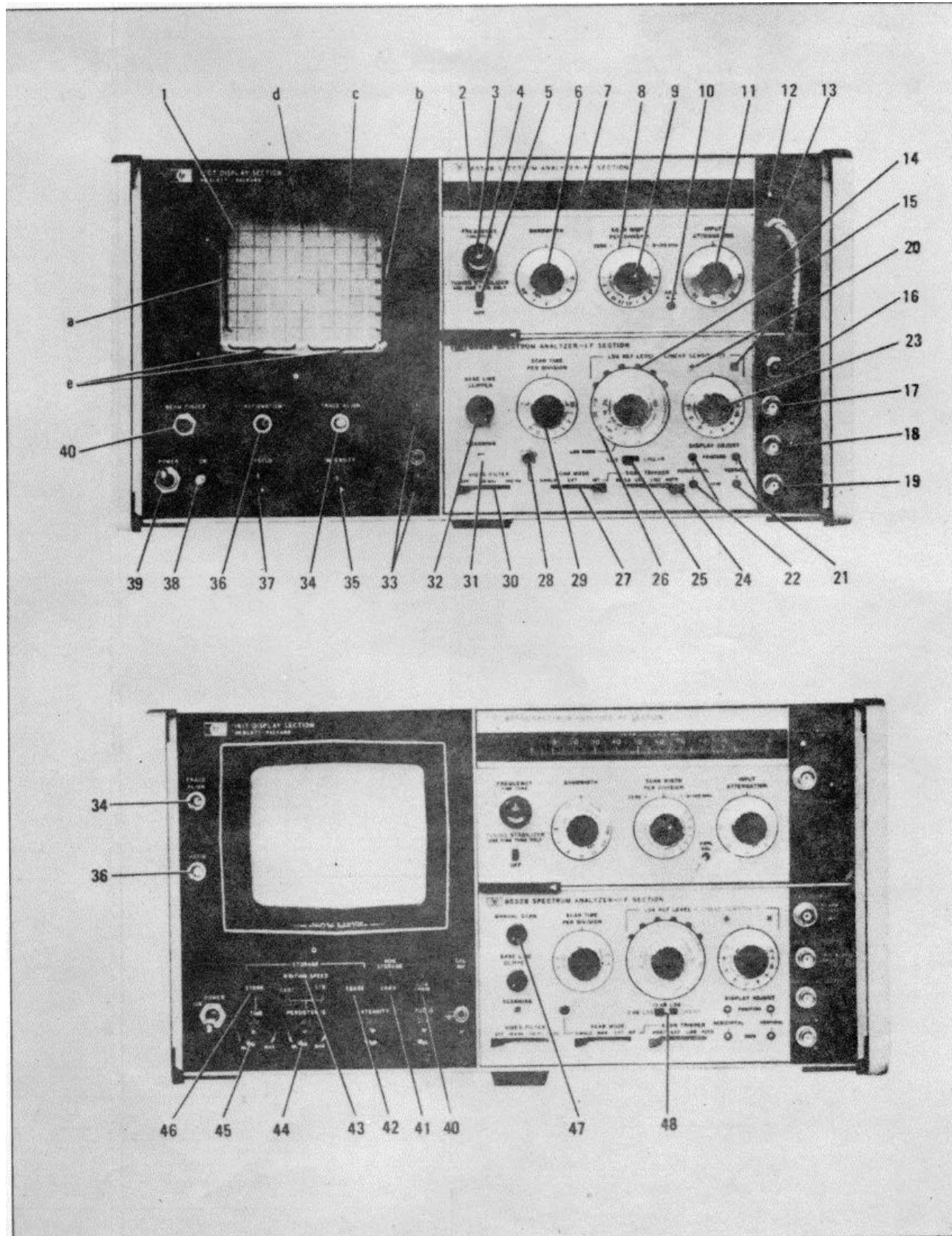

Figure 3-1. Spectrum Analyzer Controls, Indicators and Connectors (cont'd)

INPUT POWER AND INTENSITY MODULATION

1. Set 115/230 switch to correspond with available input voltage. (The instrument is fused for 115-volt, 50/60 Hz operation; if 230-volt power is used, refer to the display section service manual for fuse replacement procedures.)
2. Set INT/EXT switch to INT. (Set to EXT only if CRT is to be externally modulated - normally used with 1400-series time-domain plug-ins.)
3. Connect 8553B Load Assembly A14.

FOCUS AND ASTIGMATISM ADJUSTMENTS

4. Set:
POWER ON (up observe that ON lamp lights)
BASE LINE CLIPPER, fully ccw
SCAN WIDTH (inner/red) to ZERO
INPUT ATTENUATION to 10 dB
BANDWIDTH to .3 kHz
SCAN TIME PER DIVISION to 10 SECONDS
SCAN MODE to INT SCAN TRIGGER to AUTO
LOG REF LEVEL controls: -20 dBm graduation matching lighted index lamp and vernier set to 0
INTENSITY clockwise until trace is medium bright (approx. 1 o'clock position).
RANGE-MHz to 0-110
5. Adjust FOCUS and ASTIGMATISM controls until combined effect produces best resolution (maximum roundness without fuzz) of the dot.

TRACE ALIGNMENT

6. Set SCAN TIME PER DIVISION to 5 MILLISECONDS.
7. If not already aligned, adjust TRACE ALIGN until trace is aligned with horizontal line of graticule. HORIZONTAL POSITION AND GAIN
8. For convenience in making these adjustments, move trace to upper half of graticule by adjusting the VERTICAL POSITION control.
9. Rotate HORIZONTAL GAIN until trace is of minimum length.
10. Rotate HORIZONTAL POSITION until trace is centered on CENTER FREQUENCY line of graticule.
11. Alternately adjust HORIZONTAL POSITION/GAIN controls until trace begins at first line of graticule and ends at last.

12. Readjust VERTICAL POSITION until trace aligns with bottom line of graticule.

VERTICAL POSITION AND GAIN

13. Connect CAL OUTPUT (30 MHz/-30 dBm) signal to RF INPUT; select 0-100 SCAN WIDTH.
14. Tune FREQUENCY until negative marker causes maximum dip in signal that appears on "-2" vertical line of graticule (30 MHz) red marker on CENTER FREQUENCY MHz scale should be pointing at 30.
15. Set:
SCAN WIDTH (inner/red) to PER DIVISION
SCAN WIDTH (outer/black) to 0.2 kHz
BANDWIDTH to 300 kHz LOG-LINEAR to LOG
INPUT ATTENUATION to 10 dB
LOG REF LEVEL: -30 dBm graduation to match lighted index lamp and vernier set to 0
16. Fine-tune for max. amplitude of signal.
17. Rotate AMPL CAL until trace is centered on top line of graticule at the CENTER FREQUENCY position.
18. Rotate LOG REF LEVEL counterclockwise and note that the signal decreases one division (10 dB) for each calibrated switch position. If trace moves one division per step in lower part of graticule but the amplitude creeps upward near top of graticule, adjust VERTICAL GAIN until each step is equal.

LINEAR AND LOGARITHMIC ADJUSTMENT

19. Rotate LOG REF LEVEL control until signal trace appears on fourth graticule line from bottom.
20. Set LOG/LINEAR switch to LINEAR and rotate LOG REF LEVEL control until 1 mV/DIV is matched with the lighted index lamp.
21. Reading from bottom of graticule (LIN scale), signal amplitude should be 7.07 millivolts. If it is not, repeat vertical position and gain adjustments until proper reading is obtained.
22. Rotate LOG REF LEVEL control until -30 dBm graduation matches the lighted index lamp. Set LOG/LINEAR switch to LOG. Signal trace should align with top (LOG REF) line of the graticule.

Figure 3-2. Operational Adjustments

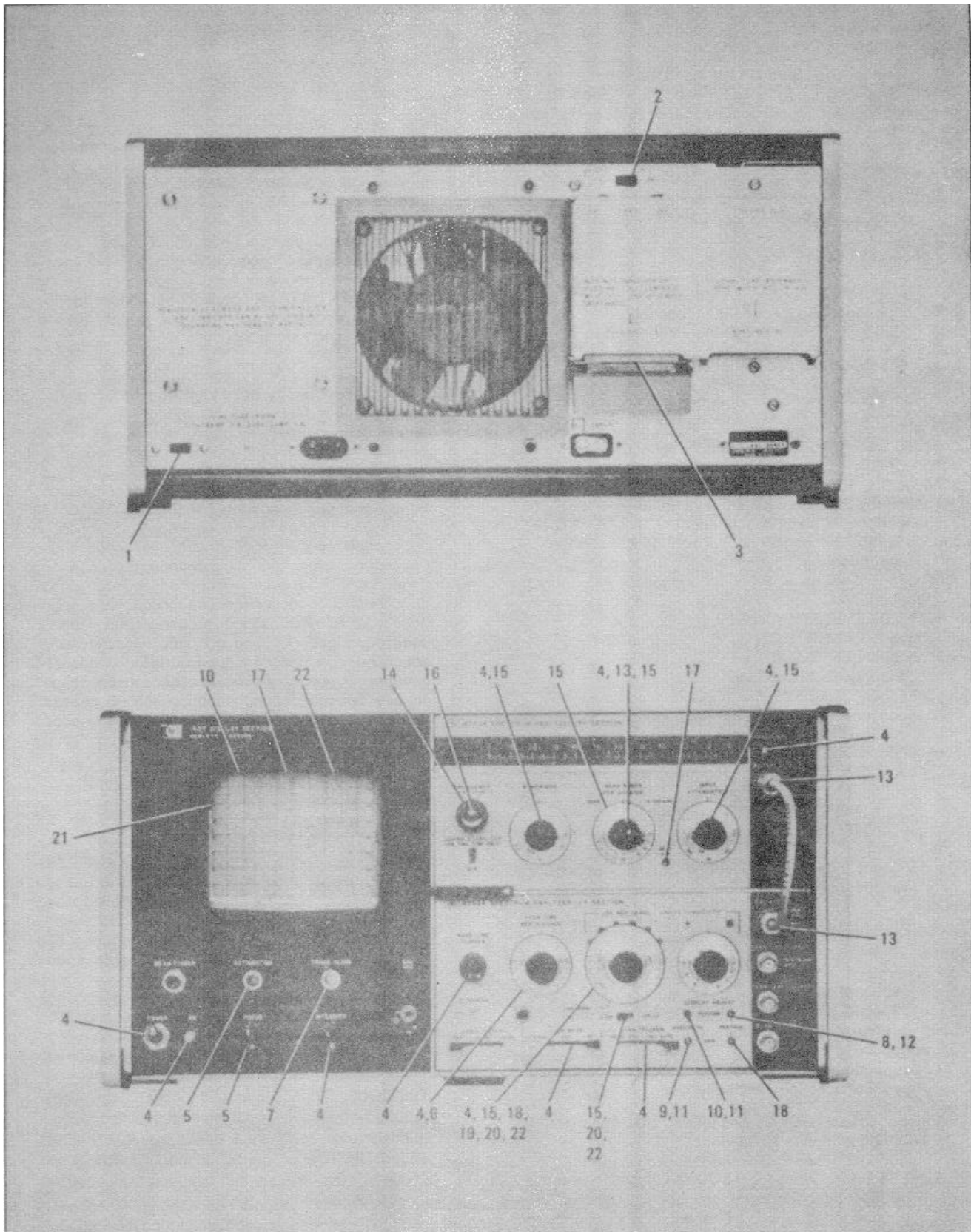

Figure 3-2. Operational Adjustments (cont'd)

Section III

PRELIMINARY SETTINGS

1. Set to correspond with available input voltage. (The instrument is fused for 115-volt operation; if 230-volt power is used, refer to fuse replacement procedures in manual on display section mainframe.
2. Plug into power outlet; use ground adapter for electrical systems having no grounding wire.
3. Set to INT.
4. Connect 8553B Load Assembly A14.
5. Set power switch to on (up); to be sure that ON lamp lights and fan operates.
6. Set INPUT ATTENUATION to 50 dB.
7. LOG REF LEVEL - LINEAR SENSITIVITY controls: Rotate large control until one of the peripheral black marks aligns with LOG NORM. Rotate (venier) small knob fully counterclockwise.
8. Set:
 VIDEO FILTER to OFF
 SCAN MODE to INT
 SCAN TRIGGER to AUTO
 LOG/LINEAR to LOG
 SCAN TIME PER DIVISION for viewing convenience
 BASELINE CLIPPER fully ccw
 SCAN WIDTH (inner/red) to 0-100 MHz
 BANDWIDTH (300 kHz automatically selected for 0-100MHz scan)
 TUNING STABILIZER to on (up)
 RANGE-MHz to 0-110
9. Adjust focus and INTENSITY for best resolution of baseline trace.

SIGNAL CONNECTION & IDENTIFICATION

CAUTION

To avoid mixer burnout, attenuator damage or both, the RF INPUT should never exceed 104 Vac peak or ±50 Vdc.

10. Connect any unknown signal within frequency range of 1 kHz to 110 MHz.
11. Set INPUT ATTENUATION so that signal amplitude is adequate for viewing.
12. Tune with coarse FREQUENCY until negative marker causes maximum "dip" in signal of interest. Read frequency under red marker on CENTER FREQUENCY MHz scale.

EXPANDING SIGNAL FOR STUDY AND MEASUREMENT

13. Set SCAN WIDTH (inner/red) switch to PER DIVISION: set (outer/black) switch to provide the necessary spectrum detail. (Select blue numbers to narrow the viewed spectrum; select black numbers to widen the viewed spectrum.)
14. Adjust coarse and fine FREQUENCY controls to center the signal of interest.
15. Select BANDWIDTH compatible with input-signal parameters, but not one which causes DISPLAY UNCAL to light.
16. Use LOG REF LEVEL control to establish calibrated power level of LOG REF line of graticule. Read power level of signal directly by adding power figure (dBm) opposite the lighted index lamp to the difference between signal peak and LOG REF line. (Example: -50 dBm opposite lighted index lamp and signal peak at center graticule line of display, then
 signal power level = -50 + (-40)
 = -90 dBm
17. Set LOG/LINEAR switch to LINEAR. Use LOG REF LEVEL to establish per-division linear multipliers (μV/DIV). If necessary, set venier control for sub-multiplier. Multiply number of graticule divisions that enclose signal by selected multipliers. (Example: signal peak at center line of display graticule, 1 μV/DIV opposite lighted index lamp, and venier set to .5 - signal amplitude, reading from bottom of graticule = 4 divisions x 1 μV/DIV x .5 = 2 μV).

DISPLAY CALIBRATION

18. Absolute amplitude calibration of the CRT display is directly related to setting of the following controls: SCAN TIME PER DIVISION, BANDWIDTH, SCAN WIDTH PER DIVISION and the VIDEO FILTER. During operation, the settings of these controls are continually monitored and, if the combination of settings will not permit a calibrated display, the DISPLAY UNCAL lamp lights. With the VIDEO FILTER switch set to OFF, typical values for ON/OFF conditions of the DISPLAY UNCAL lamp are given in Table 3-1. When the tables indicate the DISPLAY UNCAL lamp to be "off", it is acceptable for the light to be "on" if the light subsequently goes "off" when either the SCAN TIME PER DIVISION or the SCAN WIDTH PER DIVISION control is switched one position counterclockwise.

Figure 3-3. General Operating Procedures

Section III

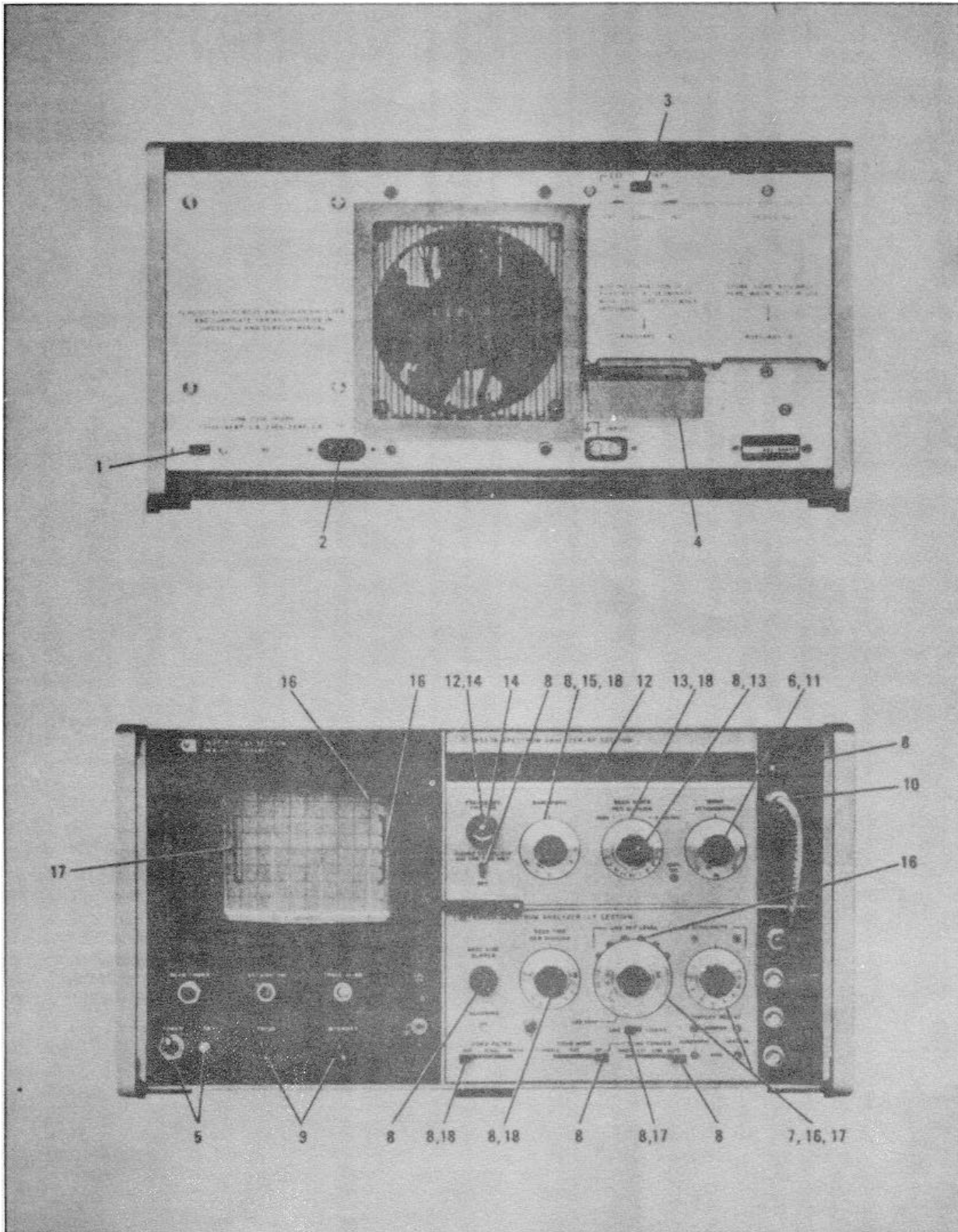
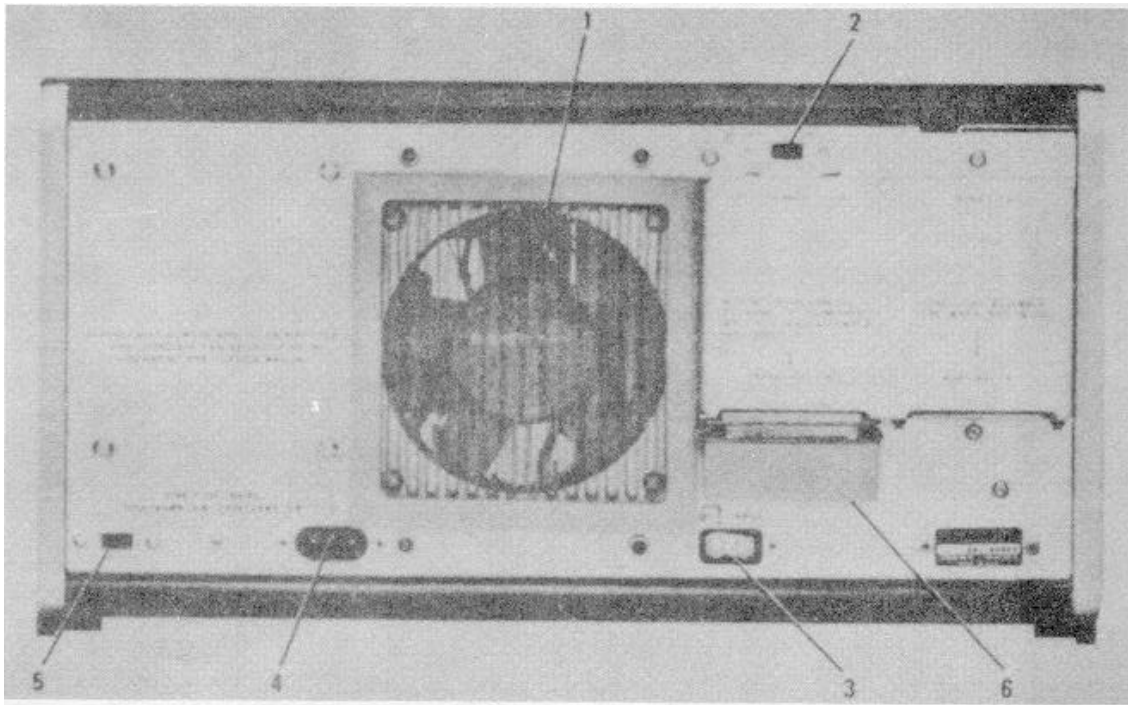

Figure 3-3. General Operating Procedures (cont'd)

Section III



1. Cooling fan and filter.
2. Selects INTernal, EXTernal or Z axis modulation of CRT control grid.
3. Z-axis input connector.
4. Input power receptacle.

5. Set for operation from 115V/50-60 Hz or 220V/50 Hz line.
6. Control functions to tracking generator.

NOTE

When a tracking generator is not connected to this plug it must be terminated with the 8553B Load Assembly A14 (08553-60122).

Figure 3-4. Spectrum Analyzer, Rear Panel Controls and Connectors

Section III

Table 3-1. Display Calibration Conditions (8553B/8552A)

Scan Time Per Division	Bandwidth	Scan Width Per Division	Display Uncal
1 ms	300 kHz	10 MHz	Off
1 ms	100 kHz	10 MHz	On
1 ms	100 kHz	5 MHz	Off
1 ms	30 kHz	5 MHz	On
5 ms	30 kHz	2 MHz	Off
5 ms	10 kHz	2 MHz	On
20 ms	10 kHz	1 MHz	Off
20 ms	3 kHz	1 MHz	On
0.1 s	3 kHz	0.5 MHz	Off
0.1 s	1 kHz	0.5 MHz	On
0.5 s	1 kHz	0.2 MHz	Off
0.5 s	0.3 kHz	0.2 MHz	On
2s	0.3 kHz	0.1 MHz	Off
2s	0.1 kHz	0.1 MHz	On
10 s	0.1 kHz	.05 MHz	Off
10 s	.05 kHz	.05 MHz	On
5 s	0.1 kHz	20 kHz	Off
2s	0.1 kHz	20 kHz	On
2s	0.1 kHz	10 kHz	Off
1s	0.1 kHz	10 kHz	On
1 s	0.1 kHz	5 kHz	Off
0.5 s	0.1 kHz	5 kHz	On
0.5 s	0.1 kHz	2 kHz	Off
0.2 s	0.1 kHz	2 kHz	On
0.2 s	0.1 kHz	1 kHz	Off
0.1 s	0.1 kHz	1 kHz	On
0.1 s	0.1 kHz	1 kHz	Off
50 ms	0.1 kHz	0.5 kHz	On
50 ms	0.1 kHz	0.2 kHz	Off
20 ms	0.1 kHz	0.2 kHz	On
20 ms	0.1 kHz	0.1 kHz	Off
10 ms	0.1 kHz	0.1 kHz	On
10 ms	0.1 kHz	.05 kHz	Off
5 ms	0.1 kHz	.05 kHz	On
5 ms	0.1 kHz	.02 kHz	Off

Section IV

SECTION IV
PERFORMANCE TESTS

4-1. INTRODUCTION

4-2. This section contains performance tests for the 8553B Spectrum Analyzer RF Section. A display section and IF section are required for performance tests. Tests for performance of the display section and IF section are contained in separate manuals and should be performed prior to checking the RF section. Perform tests in this section in procedural order with the test equipment called for, or with its equivalent.

4-3. Specifications of test equipment and accessories required to performance-test the RF section are given in Table 4-1; a complete list of accessories and test equipment, including those required for alignment, adjustment, and service, are given in Tables 1-3 and 1-4.

4-4. Front panel checks for routine inspection are given in Table 4-2. Procedures for verifying that the instrument meets specifications are given in Paragraphs 4-23 through 4-31, and a test card in able 4-3 contains data spaces for recording test results.

4-5. FRONT PANEL CHECKS

4-6. Before proceeding to the performance tests, the instrument must be adjusted and all controls set as specified in the preset adjustment instructions in Paragraph 4-13. After the instrument is set up, proceed with the checks. The instrument should perform as called out in the procedure before going on to the performance tests (Paragraphs 4-23 through 4-31).

4-7. PERFORMANCE TESTS

4-8. The performance tests given in this manual are suitable for incoming inspection, troubleshooting, or preventive maintenance. During any performance test , all shields and connecting hardware must be in place and the RF section and IF section must be installed in the display section.

The tests are designed to verify published instrument specifications. Perform the tests in the order ,given, and record data on test card (Table 4-3) and/or in the data spaces provided in each test.

4-9. The tests are arranged in the following order:

<u>Paragraph</u>	<u>Test Description</u>
4-23	Input Impedance
4-24	Scan Width Accuracy
4-25	Tuning Dial Accuracy
4-26	Frequency Response
4-27	Average Noise Level
4-28	Spurious Responses
4-29	Residual Responses
4-30	Noise Sidebands
4-31	Local Oscillator Stability and Residual Frequency Modulation

4-10. Each test is arranged so that the specification is written as it appears in the Table of Specifications in Section I. Next, a description of the test and any special instructions or problem areas is included. Each test that requires test equipment has a test setup drawing and a list of required equipment. Step 1 of each procedure gives control settings required for that particular test.

4-11. Required specifications for test equipment are detailed in Table 4-1. If substitute test equipment is to be used, it must meet the specifications listed in order to performance-test the analyzer.

4-12. FRONT PANEL CHECK PROCEDURE

4-13. Preset Adjustments

4-14. Apply power to the analyzer and while the instrument is warming up, make the following control settings:

RANGE MHz .	0-110
FREQUENCY	40 MHz
FINE TUNE.....	Centered
BANDWIDTH.....	.300 kHz
SCAN WIDTH0-100 MHz
SCAN WIDTH PER DIVISION10 MHz
INPUT ATTENUATION.....	.10 dB
TUNING STABILIZER.....	On
BASE LINE CLIPPER.....	. ccw
SCAN TIME PER DIVISION	5 MILLISECONDS
LOG REF LEVEL-10 dBm
LOG REF LEVEL Vernier.....	ccw
LOG/LINEAR	LOG
VIDEO FILTER	10 kHz
SCAN MODE .	.INT
SCAN TRIGGER .	AUTO

Section IV

4-15. Connect CAL OUTPUT to RF INPUT using a BNC-to-BNC cable. The analyzer CRT display should be similar to that shown in Figure 4-1.

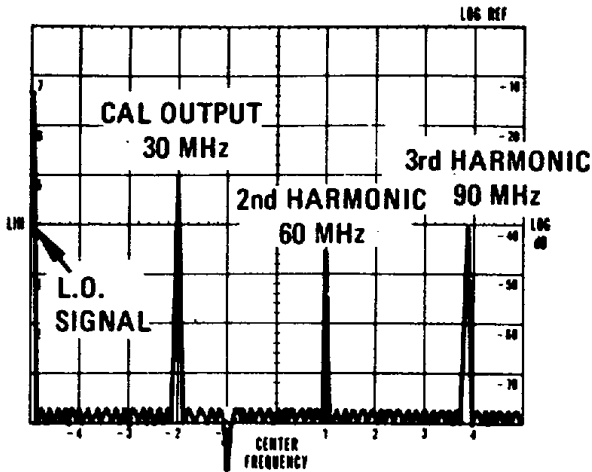

Figure 4-1. 30 MHz Calibrator Signal and Harmonics

4-16. Display Section Adjustments.

- a. Set IF section LOG REF LEVEL control max ccw and SCAN TIME PER DIVISION control to 10 SECONDS.
- b. Adjust display section FOCUS and ASTIGMATISM controls for the smallest round spot possible.
- c. Reset SCAN TIME PER DIVISION control to 5 MILLISECONDS and adjust TRACE ALIGN so that the horizontal base line of the CRT trace is exactly parallel to the horizontal graticule lines.

4-17. IF Section Adjustments

- a. Adjust VERTICAL POSITION so that the horizontal base line of the CRT trace is exactly on the bottom horizontal graticule line of the CRT. Set LOG REF LEVEL to 0 dBm.
- b. Adjust HORIZONTAL POSITION so display is centered on CRT. Then adjust HORIZONTAL GAIN until the displayed scan width is exactly 10 divisions. Some interaction between HORIZONTAL POSITION and GAIN may occur, requiring slight readjustment of the controls. The display on your CRT should now match Figure 4-1 almost exactly. (The amplitudes of the individual signals may be slightly different.)
- c. Note the inverted marker below the bottom graticule line. This marker indicates the 4-2 display Center Frequency of the ZERO and SCAN WIDTH PER DIVISION tuning modes. Adjust the FREQUENCY

control to place this marker exactly under the signal two divisions from left of center. This signal is the 30 MHz calibrator signal. Tune the marker carefully to null the signal.

NOTE

The other signals on the display are the "zero frequency" First LO feedthrough and the 60 MHz and 90 MHz harmonics of the calibrator signal.

- d. Set the SCAN WIDTH PER DIVISION control to .05 MHz and the BANDWIDTH to 10 kHz.
- e. Switch the red SCAN WIDTH control to the PER DIVISION position. The BANDWIDTH, SCAN WIDTH PER DIVISION, and Center Frequency are now those selected in steps c and d. (The marker makes it easy to select any signal in 0-100 MHz scan and expand the display about that signal.)
- f. Adjust FREQUENCY tuning to center 30 MHz calibrator signal, if necessary. Then reduce SCAN WIDTH PER DIVISION to 10 kHz. Use FINE TUNE to center the signal on the display. The analyzer's First LO is automatically phase locked to a crystal oscillator reference for the blue color-coded SCAN WIDTH positions since the TUNING STABILIZER was set to ON. Therefore, the FREQUENCY control which tunes the First LO should not be used to tune the analyzer; frequency would tune in 100 kHz steps.)
- g. Adjust the LOG REF LEVEL controls so the maximum signal amplitude is exactly on -70 dB graticule line. Rotate LOG REF LEVEL control seven steps in the clockwise direction. The amplitude of the signal should increase in increments of one division per 10-dB step. See Figure 4-2.

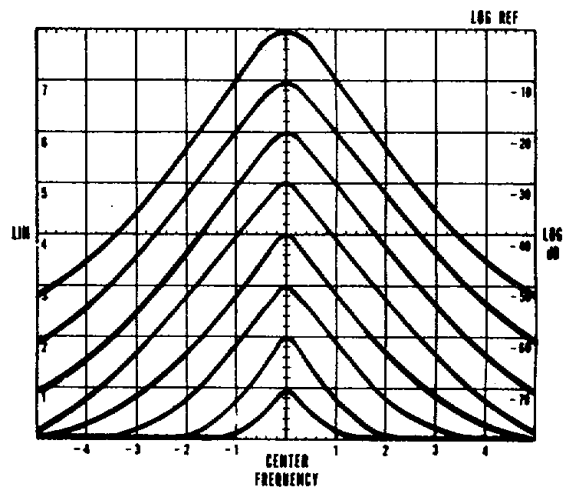

Figure 4-2. Vertical Gain Adjustment

Section IV

Table 4-1. Accessories and Test Equipment Required for Performance Tests

Item	Minimum Specifications or Required Features	Suggested Model
Tunable RF Voltmeter	Bandwidth: 1 kHz Frequency Range: 10-110 MHz Sensitivity: 10 mV to 1 V rms Input ≥ 0.1 megohms	HP 8405A Vector Voltmeter
Frequency Comb Generator	Frequency markers spaced 1, 10 MHz apart; usable to 110 MHz Frequency Accuracy: $\pm 0.01\%$	HP 8406A Comb Generator
Oscillator	Frequency Range: 1 kHz to 10 MHz Output Amplitude Flatness: 30 dBm +2% Output Impedance: 50 ohms	HP 651B Test Oscillator
HF Signal Generator	Frequency Range: 1-40 MHz Output Amplitude: -40 dBm Output Amplitude Accuracy: + 1% Frequency Accuracy: $\pm 1\%$ Output Impedance: 50 ohms	HP 606A/B HF Signal Generator
VHF Signal	Frequency Range: 10-110 MHz Frequency Accuracy: 1% Output Amplitude: ≥ -30 dBm Output Impedance: 50 ohms	HP 608E/F VHF Signal Generator
Audio Oscillator	Frequency Range: 50 kHz Output Amplitude: 2 V rms Frequency Accuracy: $\pm 2\%$ Output Impedance: 600 ohms	HP 200 CD Audio Oscillator
AC Voltmeter	Voltage Accuracy: 3% of reading Voltage Range: 30 mV full scale Input Impedance: 10 megohms	HP 400E AC Voltmeter
RF Impedance Meter	Frequency Range: 500 kHz - 108 MHz Accuracy: $\pm 5\%$	HP 4815A RF Vector Impedance Meter with HP 00600A Probe Accessory Kit
50-ohm Termination	Frequency Range: DC to 500 kHz VSWR: 1.1 Power Rating: 0.5 Watts Connector: BNC Male	HP 11593A
Cable Assembly	BNC Male to Dual Banana Plug, 45 inches long	HP 11001A
Cable Assembly (5)	Male BNC Connectors, 48 inches long	HP 10503A
50-ohm Tee	Type N female connectors on two ports, with the third port able to accept HP 8405A probe tips	HP 11536A 50-ohm Tee
Adapter (2)	BNC Female to Type N Male	UG-201A/U HP 1250-0780
BNC Tee	Two BNC Female Connectors, One Male BNC Connector	UG-274A/U HP 1250-0781

Section IV

h. Adjust VERTICAL GAIN to place maximum signal amplitude exactly on LOG REF (top) graticule line, Figure 4-2. Repeat Steps g and h to obtain optimum adjustment of VERTICAL GAIN (increments as close to one division per 10 dB step as possible).

4-18. Ampl Cal Adjustment (RF Section)

- a. Set the LOG REF LEVEL controls to -30 dBm (-30 + 0).
- b. Adjust AMPL CAL so that the signal amplitude (-30 dBm) is exactly on the LOG REF (top) graticule line of the CRT. The analyzer is now calibrated in the LOG display mode.

4-19. Ampl Cal Check for Linear Sensitivity Accuracy

4-20. In the LINEAR display mode the vertical display is calibrated in absolute voltage. For LINEAR measurements the LIN scale factors on the left side of the CRT and the blue color-coded scales of the LINEAR SENSITIVITY controls are used. The signal voltage is the product (note lighted "x" lamp) of the CRT deflection and the LINEAR SENSITIVITY control settings. It is

usually most convenient to normalize the LINEAR SENSITIVITY vernier by setting it to "1" (blue scale).

- a. Set the LOG/LINEAR switch to LINEAR. Set LINEAR SENSITIVITY to 1 mV/div (1 mV x 1). Since the -30 dBm calibrator output is = 7.1 mV (across 50 ohms), the CRT deflection should be 7.1 divisions.
- b. Adjust AMPL CAL on 8553B for a 7.1 division CRT deflection, if necessary. (LINEAR display is more expanded than the compressed LOG display, so adjustment of the AMPL CAL control can be made with more resolution in LINEAR without noticeable effect on the LOG calibration.) The analyzer is now calibrated for both the LOG and LIN display modes.

4-21. Set controls as follows:

RANGE- MHz	0-110
SCAN WIDTH0-100 MHz
SCAN WIDTH PER DIVISION	10 MHz
BANDWIDTH	10 kHz
LOG-LINEAR	LOG
LOG REF LEVEL-10 dBm

Perform tests in Table 4-2, Front Panel Checks.

Section IV

Table 4-2. Analyzer Front Panel Checks

Function	Procedure	Result
Base Line Clipper	1. Turn BASE LINE CLIPPER cw.	1. At least the bottom 2 divisions should be blank.
Scan	2. Return clipper to ccw.	3. Scan should occur in all positions
Scan Width	3. Turn SCAN TIME across its range. 4. Return to 2 ms/div.	5. 30 MHz signal and harmonics visible. DISPLAY UNCAL light comes on.
Scan Width	5. Turn SCAN WIDTH to PER DIVISION. 6. Center CAL OUTPUT signal on display. 7. Reduce SCAN WIDTH PER DIVISION to 20 kHz/Div; use FINE TUNE to center display.	7. Signal remains on-screen, centered. DISPLAY UNCAL light is unlit.
Phase Lock	8. Carefully turn FREQUENCY.	8. Signal jumps to left or right hand of CRT (± 100 kHz). This corresponds to the 100 kHz reference oscillator in the automatic phase control circuit.
Phase Lock	9. Turn TUNING STABILIZER to OFF; use FREQUENCY to center display.	9. Signal should not jump ± 100 kHz when TUNING STABILIZER is turned off.
Phase Lock	10. Turn TUNING STABILIZER on, use FINE TUNE to center display.	10. Signal should not jump 100 KHz
Bandwidth and Display Uncal Light	11. Reduce BANDWIDTH and SCAN TIME PER DIVISION using FINE TUNE to center display.	11. Display should be stable, and viewable so long as DISPLAY UNCAL is unlit.
Bandwidth and Display Uncal Light	12. Return BANDWIDTH to 10 kHz and SCAN WIDTH PER DIVISION to 20 kHz.	
Calibration	13. Lit index light on LOG REF-LEVEL LINEAR SENSITIVITY corresponds to top line of graticule; with input attenuation at 10 dB and LOG REF LEVEL at -10 dBm, signal level is -30 dBm.	13. Calibrator signal is at -30 dBm level (2 divisions down from top of graticule).
Gain Vernier	14. Turn LOG REF LEVEL-LINEAR SENSITIVITY vernier cw.	14. Signal level increases by amount marked on vernier dial.
Attenuators	15. Turn INPUT ATTENUATION and LOG REF LEVEL-LINEAR SENSITIVITY in 10 dB steps.	15. Signal increases or decreases 1 vertical division per 10 dB step.

Section IV

PERFORMANCE TEST PROCEDURES

4-22. PERFORMANCE TEST PROCEDURES

4-23. Input Impedance

SPECIFICATION:

Input Impedance: 50-ohm nominal. Reflection Coefficient ≤ 0.13 (1.3 SWR) for input attenuator settings ≤ 10 dB.

DESCRIPTION:

The RF input impedance is checked in two steps over the frequency range of 2 kHz to 110 MHz. A vector impedance meter is used to check the 500 kHz to 110 MHz range. Over the 2 kHz to 500 kHz range, an oscillator is terminated in a known impedance and calibrated. The voltage across the know impedance is then compared with the voltage across the analyzer input.

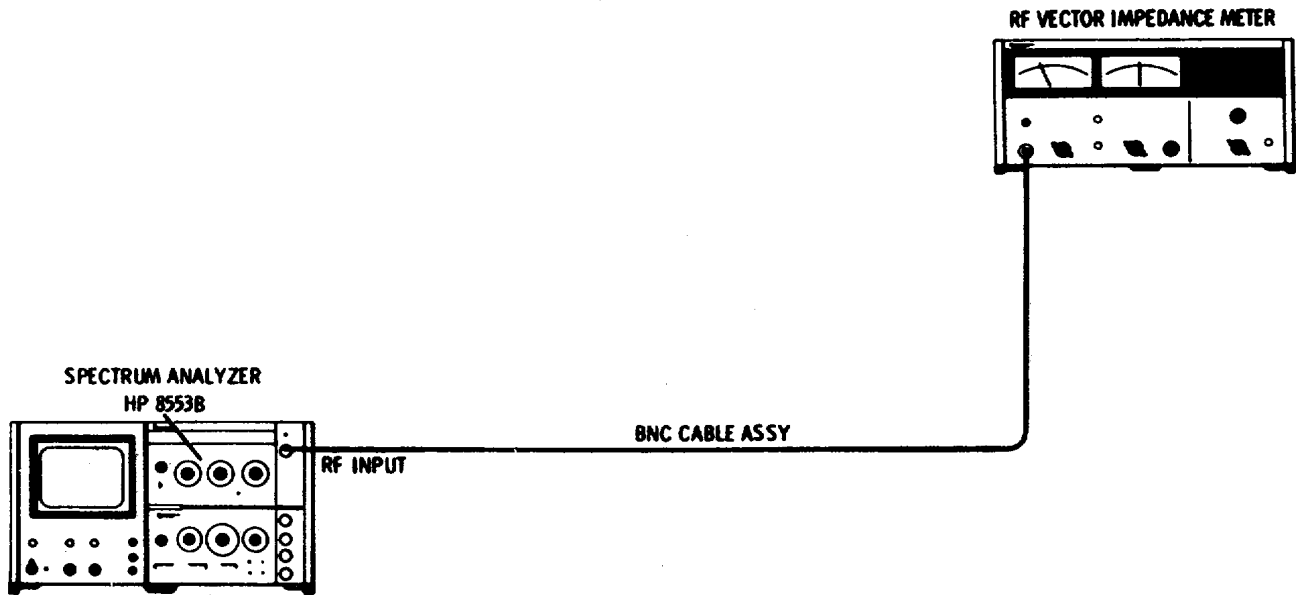

Figure 4-3. Input Impedance Accuracy Test: 500 kHz to 110 MHz

EQUIPMENT:

RF Impedance Meter	HP 4815A
Test Oscillator	HP 651B
AC Voltmeter	HP 400E
50-ohm Termination	HP 11593A
BNC Cable Assembly (2)	HP 10503A
BNC Tee	UG-274B/

1 Connect equipment as shown in Figure 4-3 and make the following control settings:

ANALYZER:

RANGE MHz	0-11
FREQUENCY	30 MHz

Section IV

PERFORMANCE TESTS (cont'd)

4-23. Input Impedance (cont'd)

ANALYZER Control Settings (cont'd)

BANDWIDTH	10 kHz
SCAN WIDTH	PER DIVISION
SCAN WIDTH PER DIVISION	0.1 MHz
INPUT ATTENUATION.....	30 dB
SCAN TIME PER DIVISION	5 MILLISECONDS
LOG/LINEAR.....	LINEAR
LINEAR SENSITIVITY.....	2 mV/DIV
TUNING STABILIZER	ON
VIDEO FILTER.....	OFF
SCAN MODE.....	INT
SCAN TRIGGER.....	AUTO

4815A

MAGNITUDE RANGE (a)	100
RANGE MHz	0.5-1.5

2. Slowly tune impedance meter through each frequency band. Observe OHM meter for indicated impedance. For a VSWR of less than 1.3 the meter should indicate between 38.5 and 65 ohms.

38.5__ 65 ohms

3. Connect test oscillator and voltmeter as indicated in Figure 4-4.

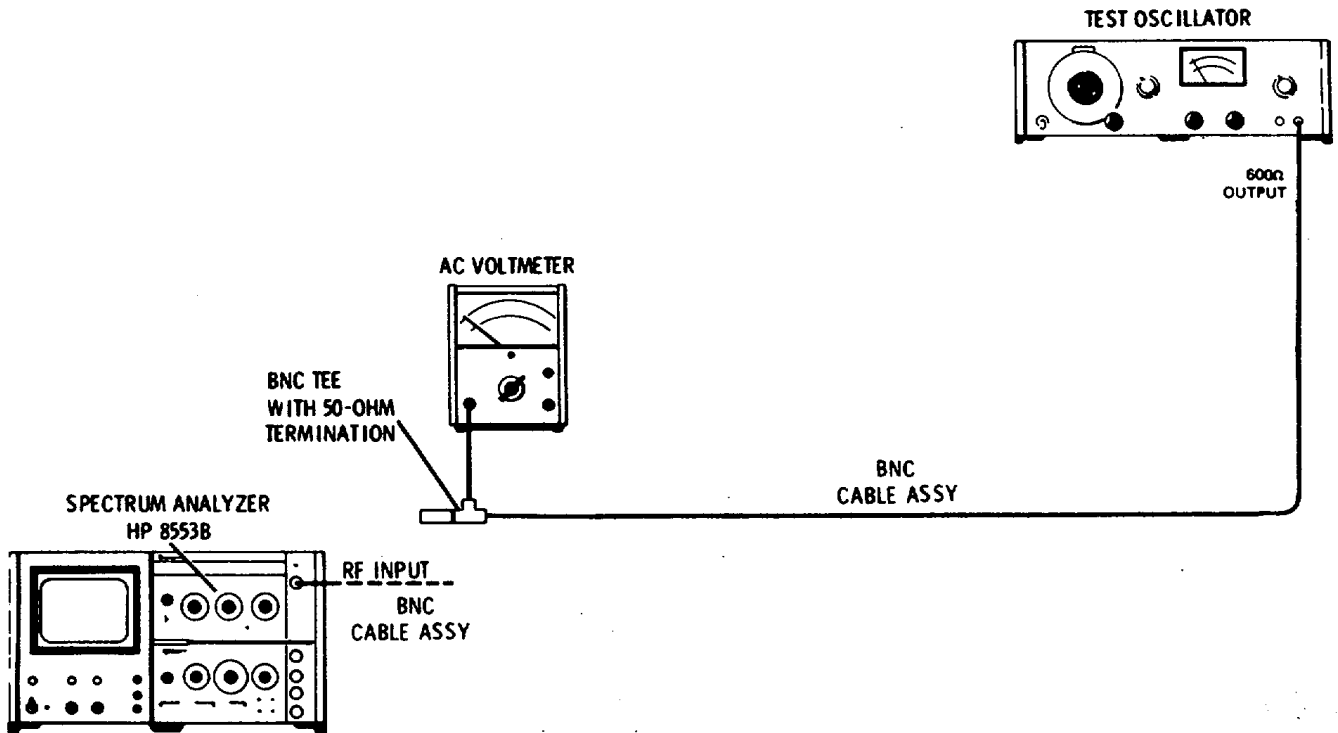

Figure 4-4. Input Impedance Accuracy Test: 2 kHz to 500 kHz

Section IV

PERFORMANCE TESTS (cont'd)

4-23. Input Impedance (cont'd)

4. Set oscillator for 500 kHz and an output level of 15 mV indicated on the voltmeter. -
5. Replace 50-ohm Termination with a cable assembly and connect to analyzer RF INPUT.
6. Measure voltage across analyzer input. For a VSWR of less than 1.3 the voltmeter should indicate should indicate between 11.8 and 19.0 mV. 11.8 _____ 19.0 mV
7. Change oscillator frequency in steps from 500 kHz to 2 kHz. Repeat steps 3 through 6 at each frequency step.
8. Repeat steps 1 - 7 with INPUT ATTENUATION set to 20 dB, then 10 dB.

4-24. Scan Width Accuracy

SPECIFICATION:

Scan widths 10 MHz/div and 20 kHz/div to 20 Hz/div (8552B) or 200 kHz (8552A); frequency error between two points on the display is less than +3% of the indicated frequency separation between the two points. Scan widths 1 MHz/div to 50 kHz/div; frequency error between two points on the display is less than +10% of the indicated frequency separation.

DESCRIPTION:

Wide scan widths are checked directly using a comb generator. Narrow scan widths are checked using a comb generator modulated by an audio oscillator. Comb generator frequency components line up opposite graticule lines, and the amount of error is measured at the +3 graticule line.

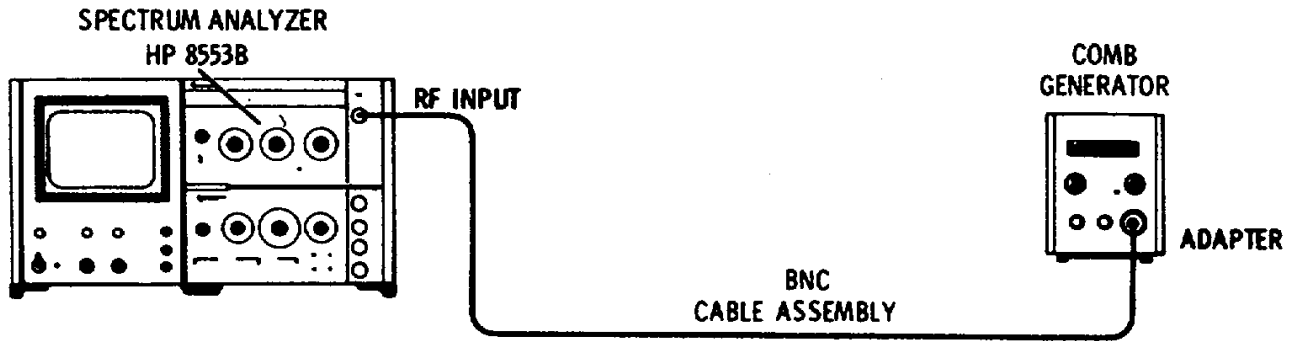

Figure 4-5. Scan Width Accuracy Test: 10 MHz/Div

EQUIPMENT:

Comb Generator	HP 8406A
Audio Oscillator	HP 200CD
BNC Cable Assembly.....	HP 10503A
Cable Assembly.....	HP 11001A
Type N to BNC Adapter	UG-201A/U

Section IV

PERFORMANCE TESTS (cont'd)

4-24. Scan Width Accuracy (cont'd)

1. Connect the test setup in Figure 4-5 and make the following control settings:

ANALYZER

RANGE MHz	0-110
FREQUENCY	60 MHz
BANDWIDTH	300 kHz
SCAN WIDTH	PER DIVISION
SCAN WIDTH PER DIVISION	10 MHz
INPUT ATTENUATION	0 dB
SCAN TIME PER DIVISION	2 MILLISECONDS
LOG REF LEVEL	-20 dBm
VIDEO FILTER	OFF
SCAN MODE	INT
SCAN TRIGGER	AUTO
LOG-LINEAR	LOG

8406A

COMB FREQUENCY - MC	10 Mc
INTERPOLATION AMP	OFF
OUTPUT AMPLITUDE	3 o'clock

2. With control settings as in step 1 above, a comb signal occurs every 10 MHz on the display (see Figure 4-6). Turn FREQUENCY and FINE TUNE to line up a comb signal with the far left graticule line.
3. Measure the amount of error, in divisions, that the comb signal deviates from the +3 graticule line. The comb signal should occur on the +3 line +0.24 divisions.

+2.76 _____ +3.24 (on display)

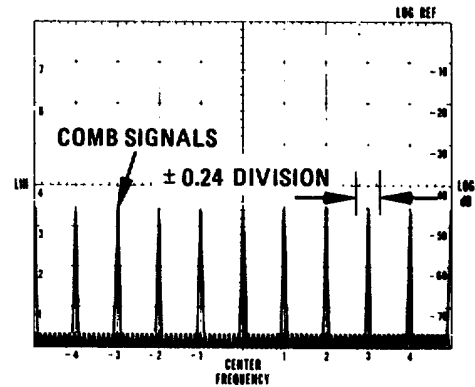

Figure 4-6. Scan Width Accuracy Measurement

4. To test .05 MHz SCAN WIDTH PER DIVISION setting, connect test equipment as shown in Figure 4-7.

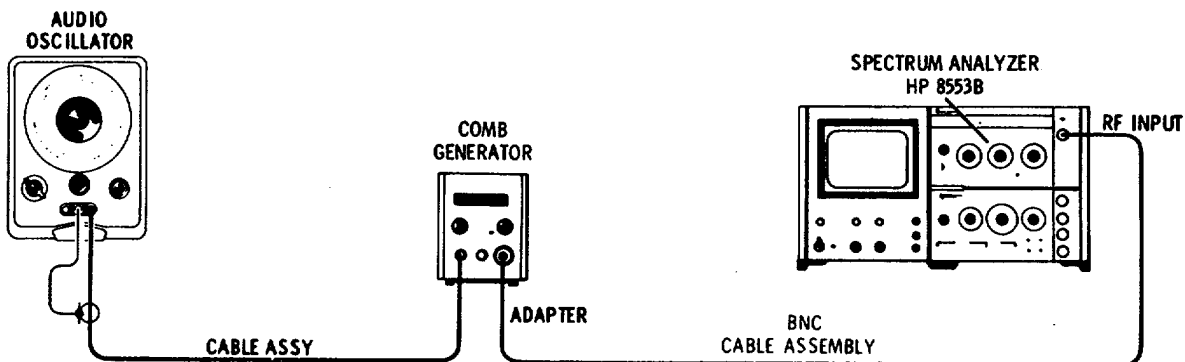

Figure 4-7. Scan Width Accuracy Test: .05 MHz/Div

Section IV

PERFORMANCE TESTS (cont'd)

4-24. Scan Width Accuracy (cont'd)

Set controls as follows:

ANALYZER:

BANDWIDTH..... 3 kHz
 SCAN TIME PER DIVISION 10 MILLISECONDS
 SCAN WIDTH PER DIVISION 05 MHz

200CD

RANGE..... X1K
 FREQUENCY 50 kHz
 AMPLITUDE 3 o'clock

8406A

COMB FREQUENCY - MC 10 Mc

5. Maximize the comb signal amplitudes using the comb generator and audio oscillator output amplitude controls.
6. With controls set as in step 4 above, a comb signal occurs every 50 kHz on the display. Turn FINE TUNE to line up a comb signal with the far left graticule line.
7. Measure the amount of error, in divisions, that the comb signal deviates from the +3 graticule line. The comb signal should occur on the +3 line +0.8 divisions.

+2.2 _____ +3.8 (on display)

8. To test the 20 kHz SCAN WIDTH PER DIVISION, set test equipment as follows:

ANALYZER:

BANDWIDTH..... 3 kHz
 SCAN TIME PER DIVISION 5 MILLISECONDS
 SCAN WIDTH PER DIVISION 20 kHz

8406A:

COMB FREQUENCY - MC 10 Mc

200CD

RANGE..... X1K
 FREQUENCY 20 kHz
 AMPLITUDE 3 o'clock

9. With the control settings as in Step 8 above, a comb signal occurs every 20 kHz on the display. Turn FINE TUNE to line up a comb signal with the far left graticule line.
10. Measure the amount of error, in divisions, that the comb signal deviates from the +3 graticule line. The comb signal should occur on the +3 line +0.24 divisions.

+2.76 _____ +3.24 (on display)

Section IV

PERFORMANCE TESTS (cont'd)

4-25. Tuning Dial Accuracy

SPECIFICATION:

Display center frequency is within +1 MHz of indicated dial frequency on the 0-110 MHz tuning range; + 200 kHz on the 0-11 MHz range with FINE TUNE centered and temperature range of 20 to 30 degrees C.

DESCRIPTION:

Dial accuracy is verified by displaying test signals of known frequency accuracy. Test signals are the fundamental and harmonics of a comb generator.

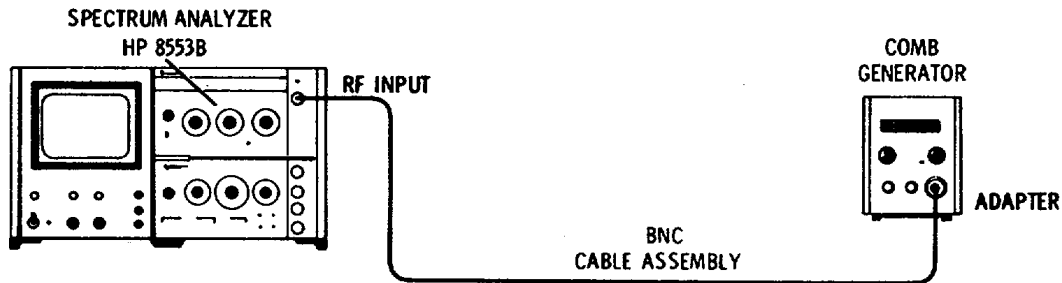

Figure 4-8. Tuning Dial Accuracy Test

EQUIPMENT:

Comb Generator	HP 8406A
BNC-to-BNC Cable Assembly	HP 10503A
Type N to BNC Adapter	UG-201A/U

1. Connect the equipment as shown in Figure 4-8. Make the following control settings:

ANALYZER:

RANGE MHz	0-10
FREQUENCY	10 MHz
BANDWIDTH	30 kHz
SCAN WIDTH PER DIVISION	1 MHz
INPUT ATTENUATION	0 dB
LOG REF LEVEL	-40 dBm
SCAN TIME PER DIVISION	10 MILLISECONDS
VIDEO FILTER	OFF
SCAN MODE	INT
SCAN TRIGGER	AUTO
LOG-LINEAR	LOG

8406A:

COMB FREQUENCY- MC	10 Mc
OUTPUT AMPLITUDE3 o'clock

2. Turn FREQUENCY to 10 MHz; a comb signal should be displayed +1 division of center graticule line.

-1 _____ +1 DIV

Section IV

PERFORMANCE TESTS (cont'd)

4-25. Tuning Dial Accuracy (cont'd)

3. Tune FREQUENCY to the remaining dial calibration points to verify accuracy.

- | | | | |
|-----------|--------------|------------|--------------|
| a. 20 MHz | -1____+1 DIV | f. 70 MHz | -1____+1 DIV |
| b. 30 MHz | -1____+1 DIV | g. 80 MHz | -1____+1 DIV |
| c. 40 MHz | -1____+1 DIV | h. 90 MHz | -1____+1 DIV |
| d. 50 MHz | -1____+1 DIV | i. 100 MHz | -1____+1 DIV |
| e. 60 MHz | -1____+1 DIV | j. 110 MHz | -1____+1 DIV |

4. Make the following control settings:

ANALYZER:

RANGE MHz 0-11
 FREQUENCY 1 MHz
 FINE TUNE..... Centrec
 BANDWIDTH..... 0 3 MHz
 SCAN WIDTH PER DIVISION 0 1 MHz

8406A:

COMB FREQUENCY - MC 1

5. Turn FREQUENCY to 1 MHz; a comb signal should be displayed in 2 divisions of center graticule line.

-2 ____ +2 DIV

6. Tune FREQUENCY to the remaining dial calibration points to verify accuracy.

- | | | | |
|----------|--------------|-----------|--------------|
| a. 2 MHz | -2____+2 DIV | f. 7 MHz | -2____+2 DIV |
| b. 3 MHz | -2____+2 DIV | g. 8 MHz | -2____+2 DIV |
| c. 4 MHz | -2____+2 DIV | h. 9 MHz | -2____+2 DIV |
| d. 5 MHz | -2____+2 DIV | i. 10 MHz | -2____+2 DIV |
| e. 6 MHz | -2____+2 DIV | j. 11 MHz | -2____+2 DIV |

Section IV

PERFORMANCE TESTS (cont'd)

4-26. Frequency Response

SPECIFICATION:

Flatness (Input attenuation ,20 dB); Log: ± 0.5 dB; Linear: $\pm 5.8\%$.

DESCRIPTION:

A flat signal source is connected to the analyzer RF INPUT. The CRT display is observed for frequency response as the input signal is tuned. The HP Model 661B is used as a signal source between 1 kHz and 10 MHz and the HP Model 608E/F (output monitored by the HP 8405A) is used between 10 MHz and 110 MHz.

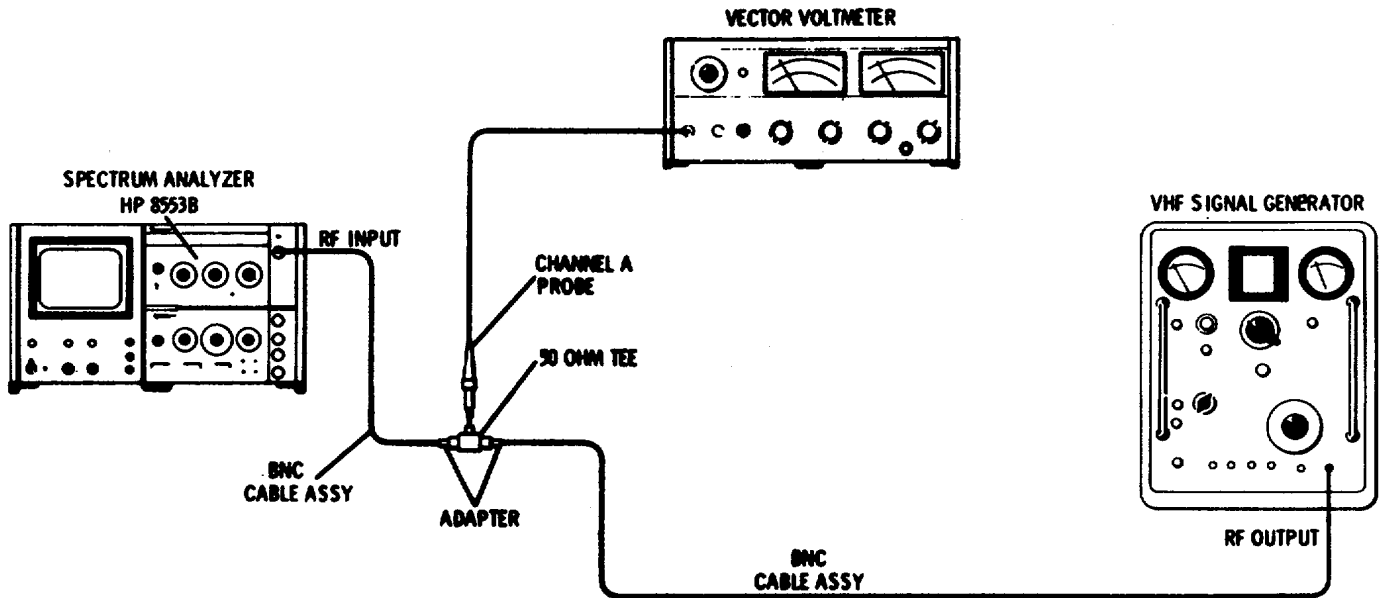

Figure 4-9. Frequency Response Test: 10 MHz to 110 MHz

EQUIPMENT:

Test Oscillator.....	HP 651B
Signal Generator.....	HP 608E/F
RF Voltmeter	HP 8405A
50-ohm Feedthrough Tee.....	HP 11536A
BNC Cable Assembly (2)	HP 10503A
Type N to BNC Adapter (2)	UG 201A/U

1. To check the analyzer frequency response from 10 MHz to 110 MHz, connect the test setup as shown in Figure 4-9
Make the following control settings

ANALYZER:

RANGE MHz	0-110
FREQUENCY	60 MHz
BANDWIDTH.....	100 kHz
SCAN WIDTH.....	PER DIVISION
SCAN WIDTH PER DIVISION	10 MHz
INPUT ATTENUATION.....	30 dB
SCAN TIME PER DIVISION	5 MILLISECONDS
LOG/LINEAR	LINEAR

Section IV

PERFORMANCE TESTS (cont'd)

4-26. Frequency Response (cont'd)

ANALYZER Control Settings (cont'd)

LINEAR SENSITIVITY 2 mV/DIV
 VIDEO FILTER OFF
 SCAN MODE INT
 SCAN TRIGGER AUTO

608E/F:

MODULATION CW
 ATTENUATION -30 dBm
 MEGACYCLES 10
 FREQUENCY RANGE A
 AMPL TRIMMER Press and peak meter reading

8405A:

FREQUENCY RANGE - MHz Setting compatible with 608E/F frequency
 CHANNEL A
 AMPLITUDE RANGE - dB -30

2. Adjust the analyzer FREQUENCY control to place 10 MHz input signal on the far left (-5) graticule line. Adjust LINEAR SENSITIVITY vernier for 7 divisions signal amplitude.
3. Tune the 608E/F signal generator from 10 MHz to 110 MHz keeping its amplitude constant by monitoring the 8405A RF Voltmeter. Be sure to peak the 608E/F AMPL TRIMMER when changing ranges. Note the frequency at which the analyzer response is maximum and reset the display amplitude at this frequency to 7.4 divisions. The frequency response of the analyzer should be between 6.6 and 7.4 divisions from 10 MHz to 110 MHz.

6.6___7.4 DIV

4. Note the display amplitude at 10 MHz.

6.6___7.4 DIV

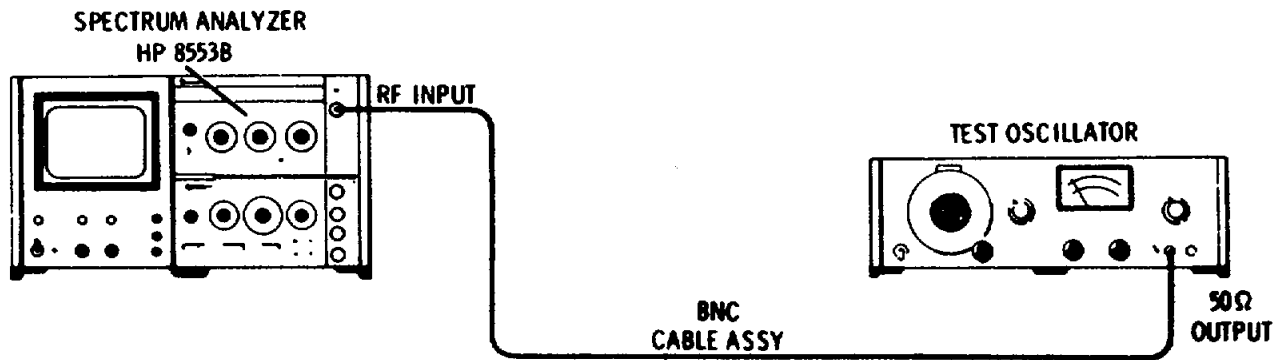

Figure 4-10. Frequency Response Test: 1 kHz to 10 MHz

Section IV

PERFORMANCE TESTS (cont'd)

Frequency Response (cont'd)

- To check the analyzer frequency response from 1 MHz to 10 MHz, connect the test setup as shown in Figure 4-10. Make the following control settings:

ANALYZER:

BANDWIDTH..... 30 kHz
 SCAN WIDTH PER DIVISION 1 MHz
 RANGE MHz 0-11

651B

FREQUENCY 10
 RANGE..... X1M
 OUTPUT ATTENUATION..... -30 dBm

- Adjust the analyzer FREQUENCY control to place the 10 MHz signal on the far right (+5) graticule line. Adjust the 651B signal level to obtain the same display amplitude as measured in step 4. Tune the 651B between 10 MHz and 1 MHz; frequency response should be between 6.6 and 7.4 linear divisions. If the response peaks above 7.4 divisions, reset the 651B level at that frequency and continue checking the frequency response in the steps below. 6.6____7.4 DIV
- Repeat step 6 to check 1 MHz to 100 kHz setting the analyzer BANDWIDTH to 10 kHz and SCAN WIDTH PER DIVISIONS to .1 MHz. Set 651B to X100K range. 6.6____7.4 DIV
- Repeat step 6 to check 100 kHz to 10 kHz setting the analyzer BANDWIDTH to 1 kHz, SCAN WIDTH PER DIVISION to 10 kHz, SCAN WIDTH PER DIVISION to 10 kHz, and FREQUENCY to place the LO signal on the far left (-5) graticule line. Set 651B to X10K range. 6.6____7.4 DIV
- Repeat step 6 to check 10 kHz to 1 kHz setting the analyzer BANDWIDTH to .1 kHz, SCAN WIDTH PER DIVISION to 1 kHz, FREQUENCY to place the LO signal on the far left (-5) graticule line. Set 651B to X1K range. 6.6____7.4 DIV
- If the 651B had to be readjusted per step 6, then repeat the response test from 10 MHz to 110 MHz by setting the 608E/F amplitude at 10 MHz to correspond with the displayed amplitude of the 651B at 10 MHz, and repeat steps 1-3.

4-27. Average Noise Level

SPECIFICATION:

<-110 dBm with 10 kHz IF bandwidth.

DESCRIPTION:

Average noise level is checked by observing the average noise power level of the analyzer with the instrument vertically calibrated and no signal input. The test is made using a 10 kHz IF bandwidth.

- Check the analyzer to make sure it is vertically calibrated. Refer to Paragraph 4-12 for instructions.
- Make the following analyzer control settings.

RANGE MHz 0-110
 FREQUENCY 110 MHz
 BANDWIDTH 10 kHz

Section IV

PERFORMANCE TESTS (cont'd)

4-27. Average Noise Level (cont'd)

ANALYZER Control Settings (cont'd)

SCAN WIDTH..... ZERO
 INPUT ATTENUATION..... 0 dB
 BASE LINE CLIPPER..... CCW
 SCAN TIME PER DIVISION 50 MILLISECONDS
 LOG REF LEVEL..... 0 dBm
 LOG REF LEVEL Vernier..... 00
 LOG-LINEAR..... LOG
 VIDEO FILTER 100 Hz
 SCAN MODE..... INT
 SCAN TRIGGER AUTO

3. Observe the average noise power level on the CRT. It should be lower than -110 dBm as shown in Figure 4-11 as frequency is tuned from 110 MHz to 1 MHz. Make sure the LOG REF LEVEL vernier is set at 0 during the measurement.

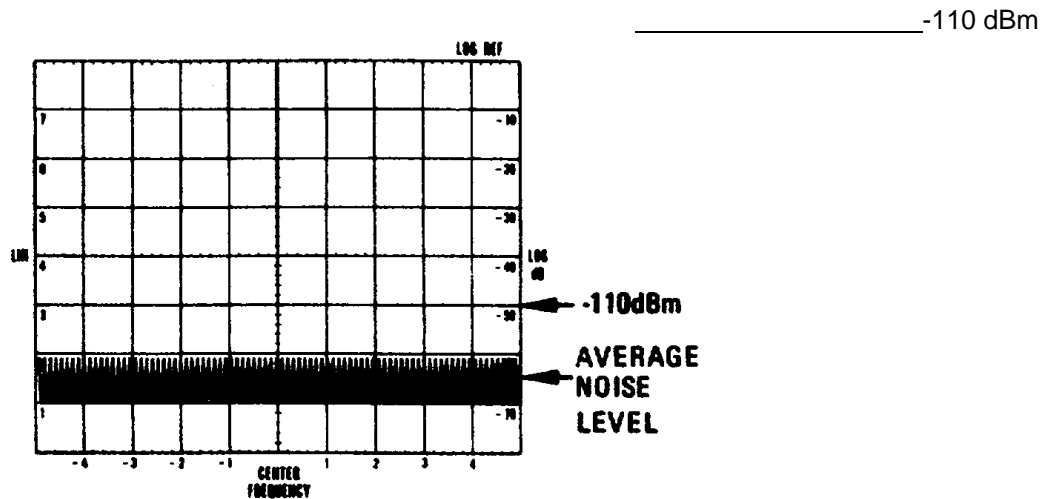

Figure 4-11. Sensitivity Measurement: CRT Display

4-28. Spurious Responses

SPECIFICATIONS:

For -40 dBm signal level at the input mixer*, image responses, out-of-band mixing responses, harmonic and intermodulation distortion and IF feedthrough responses are all more than 70 dB below the signal level at input mixer: 2 MHz to 110 MHz, 60 dB: 1 kHz to 2 MHz.

Third Order Intermodulation Products: For -40 dBm signal level at input mixer* third order intermodulation products are more than 70 dB down for input signals of 100 kHz to 110 MHz.

*Signal level at Input mixer - Signal level at RF INPUT - INPUT ATTENUATION.

Section IV

PERFORMANCE TESTS (cont'd)

4-28. Spurious Responses (cont'd)

DESCRIPTION:

To verify spurious response level the two-tone method of measuring intermodulation distortion will be used. The outputs of two signal generators, tuned 50 kHz apart, are applied to the spectrum analyzer RF INPUT. The generator levels are adjusted equally to -43 dBm (-40 dBm total power) at the analyzers input mixer. No IM products from 100 kHz to 110 MHz should be present above -110 dBm (-70 dB from -40 dBm).

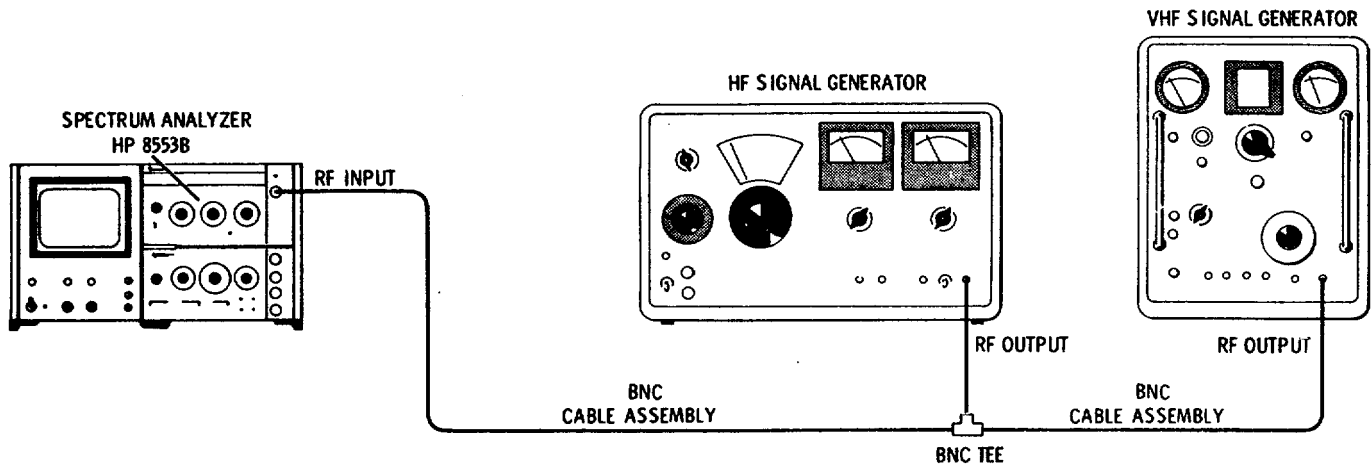

Figure 4-12. Intermodulation Distortion Test

EQUIPMENT:

Signal Generator.....	HP 606B
Signal Generator.....	HP 608F
BNC Cable Assembly (2)	HP 10503A
BNC Tee.....	UG-274B/U

1. Connect the test setup shown in Figure 4-12 and make the following control settings:

ANALYZER

RANGE MHz	0-110
BANDWIDTH	1 kHz
SCAN WIDTH PER DIVISION	20 kHz
FREQUENCY	10 MHz
INPUT ATTENUATION.....	0 dB
SCAN TIME PER DIVISION	2 MILLISECONDS
LOG REF LEVEL.....	-40 dBm
TUNING STABILIZER.....	On
VIDEO FILTER	OFF
SCAN MODE	INT
SCAN TRIGGER	AUTO

SIGNAL GENERATORS

Signal Generator No 1 (606B) FREQUENCY	9 950 MHz (approx)
Signal Generator No 2 (608F) FREQUENCY	10 MHz (approx)
AMPLITUDE	-40 dBm (approx)

Section IV

PERFORMANCE TESTS (cont'd)

4-28. Spurious Responses (cont'd)

2. Adjust the HP 608F frequency to center the signal on the CRT. Then adjust the HP 606B frequency to place its signal 50 kHz from the HP 608F signal.
3. Set SCAN TIME PER DIVISION to 50 MILLISECONDS and adjust each signal generator's attenuator so that its signal amplitude peaks 3 dB below the LOG REF graticule line (-43 dBm).
4. Tune the analyzer to 19.950 MHz and check for a second-order intermodulation product. _____ -110 dBm
5. Tune the analyzer to 10.050 MHz and check for third-order IM. Third-order products also occur at the following frequencies: 9.900 MHz, 29.950 MHz, 29.900 MHz. 10.050 MHz _____ -110 dBm

NOTE

Signal generators exhibit harmonic distortion, typically about 35 dB below fundamental level. Harmonic distortion will occur at multiples of 9.950 and 10 MHz. Care must be taken not to confuse harmonic distortion produced by the source with intermodulation distortion produced by the input mixer.

4-29. Residual Responses

SPECIFICATION:

Referred to signal level at input mixer*:
 20 kHz to 110 MHz: <-110 dBm
 20 kHz to 200 kHz: <-95 dBm.

DESCRIPTION:

Signals present on the display with no input are called residual responses. To measure residual responses, a reference is selected so that -110 dBm is easily determined. The display is searched for residual responses under the various test conditions called out.

1. Set the analyzer controls as follows:
 - RANGE MHz 0-110
 - FREQUENCY 60 MHz
 - FINE TUNE..... Centered
 - BANDWIDTH..... kHz
 - INPUT ATTENUATION..... dB
 - SCAN WIDTH..... PER DIVISION
 - SCAN WIDTH PER DIVISION 10 MHz
 - BASE LINE CLIPPERmax ccw
 - SCAN TIME PER DIVISION 10 SECONDS
 - LOG/LINEAR LOG
 - LOG REF LEVEL controls..... -60 dBm
 - TUNING STABILIZER.....On
 - VIDEO FILTER OFF
 - SCAN MODE INT k
 - SCAN TRIGGER AUTO

*Signal level at input mixer = Signal level at RF INPUT - INPUT ATTENUATION.

PERFORMANCE TESTS (cont'd)

4-29. Residual Responses (cont'd)

2. Terminate the RF INPUT jack in 50 ohms.
3. Observe the display as the analyzer scans from 10 to 110 MHz. The average noise level should be less than -110 dBm and no residual responses should occur. Figure 4-13 represents a scan with no residual response, and with the average noise level indicated.

Residual Responses 10-110 MHz:
 <-110 dBm _____

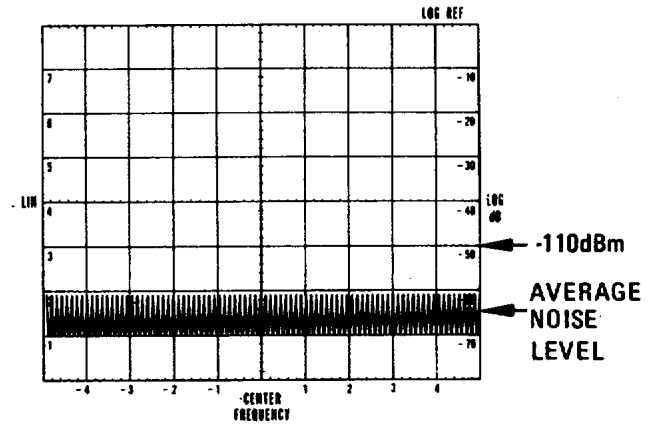

Figure 4-13. Residual Response Test: 10 to 110 MHz CRT Display

4. To check the analyzer from 1 MHz to 10 MHz, make the following control settings:
 FREQUENCY 5 MHz
 SCAN WIDTH PER DIVISION 1 MHz
 SCAN TIME PER DIVISION 2 SECONDS

Residual Responses 1-10 MHz:
 <-110 dBm _____

6. To check the analyzer from 200 kHz to 1 MHz, make the following control settings:
 FREQUENCY Local Oscillator signal appears at left hand edge of graticule
 SCAN WIDTH PER DIVISION 0.1 MHz
 BANDWIDTH 0.3 kHz
 SCAN TIME PER DIVISION 5 SECONDS

7. Observe the display for residual responses over the last 8 horizontal divisions:

Residual Responses 1-10 MHz:
 <-110 dBm _____

8. To check the analyzer from 20 to 200 kHz, make the following control settings:

RANGE - MHz 0-11 MHz
 FREQUENCY Local Oscillator signal appears at left hand of graticule
 SCAN WIDTH PER DIVISION 20 kHz
 BANDWIDTH 0 0.1 kHz
 BANDWIDTH 0.1 kHz
 SCAN TIME PER DIVISION 5 SECONDS
 LOG REF LEVEL -50 dBm

9. Observe the display for residual responses over the last nine horizontal divisions:

Residual Responses 1-10 MHz:
 <-95 dBm _____

Section IV

PERFORMANCE TESTS (cont'd)

4-30. Noise Sidebands

SPECIFICATION:

More than 70 dB below CW signal 50 kHz or more away from signal, with a 1 kHz IF BANDWIDTH setting.

DESCRIPTION:

A stable -40 dBm CW signal is applied to the spectrum analyzer and displayed on the CRT. The amplitude of the noise associated sidebands and unwanted responses close to the signal are measured.

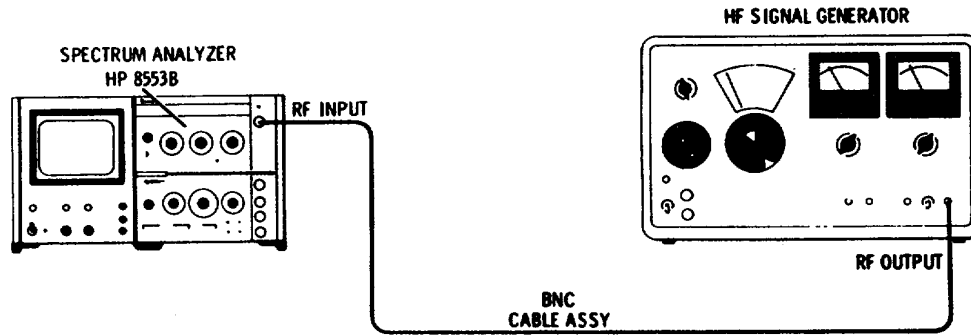

Figure 4-14. Noise Sideband Test

EQUIPMENT:

Signal Generator.....	HP 606B
BNC Cable Assembly.....	HP 10503A

1. Connect the test setup in Figure 4-14 and make the following control settings:

ANALYZER

RANGE MHz	0 -110
FREQUENCY	40 MHz
BANDWIDTH.....	1 kHz
SCAN WIDTH.....	PER DIVISION
SCAN WIDTH PER DIVISION	10 kHz
SCAN TIME PER DIVISION	1 SECOND
INPUT ATTENUATION.....	0 dB
LOG REF LEVEL.....	-40 dBm
TUNING STABILIZER.....	ON
VIDEO FILTER	100 Hz
SCAN MODE	INT
SCAN TRIGGER	AUTO
LOG/LINEAR	LOG

606B

FREQUENCY	40 MHz
ATTENUATOR	-40 dBm
MOD SELECTOR	CW

2. Tune the analyzer to center the display, and if necessary, adjust HP 606B output vernier so that the signal amplitude peaks at the top graticule line.
3. Observe the noise level five divisions or greater away from the signal (50 kHz). The average noise level should be at least 7 divisions below the signal level.

Noise Level >7 div below carrier level: _____

Section IV

PERFORMANCE TESTS (cont'd)

4-31. Local Oscillator Stability and Residual Frequency Modulation

SPECIFICATION:

Stabilized: less than 20 Hz peak-to-peak. Unstabilized: less than 1 kHz peak-to-peak.

DESCRIPTION:

The linear portion of the analyzer IF filter skirt is used to slope detect low-order residual FM. The analyzer is stabilized, and the detected FM is displayed in the time domain.

1. Make the following control settings:

ANALYZER:

RANGE MHz 0 -110
 FREQUENCY 0 (LO FEEDTHRU)
 BANDWIDTH 0 1 kHz
 SCAN WIDTH PER DIVISION
 SCAN WIDTH PER DIVISION 0 2 kHz
 INPUT ATTENUATION 0 dB
 SCAN TIME PER DIVISION 50 MILLISECONDS
 LOG/LINEAR LINEAR
 LINEAR SENSITIVITY see below
 TUNING STABILIZER ON
 VIDEO FILTER OFF
 SCAN MODE INT
 SCAN TRIGGER AUTO

2. Turn LINEAR SENSITIVITY and its vernier for a full eight-division display.
3. Refer to Figure 4-15. Tune FREQUENCY so that the upward slope of the display intersects the CENTER FREQUENCY graticule line 1 division from the top.
4. Note where the slope intersects the middle horizontal graticule line.

Horizontal _____ Displacement: divisions

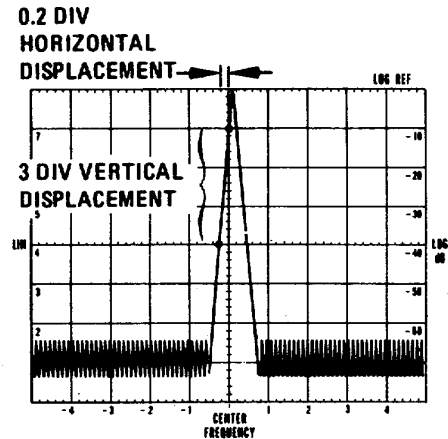

Figure 4-15. Demodulation Sensitivity Measurement.

5. Use the horizontal displacement to calculate demodulation sensitivity:
 - a. Convert the horizontal displacement (divisions) into hertz.

Example: (0.2 kHz SCAN WIDTH PER DIVISION) x (0.2 div) = 40 Hz

Section IV

PERFORMANCE TESTS (cont'd)

4-31. Local Oscillator Stability and Residual Frequency Modulation (cont.)

- b. Calculate demodulation sensitivity by dividing the vertical displacement in divisions into the horizontal displacement in Hz:

Example: $\frac{40 \text{ Hz}}{3 \text{ divisions}} = 13.3 \text{ Hz/DIV}$

NOTE

13.3 Hz/div is a typical value, and may be used for stability measurements.

- 6. Turn SCAN WIDTH to ZERO scan. Tune FINE TUNE for a response level within the calibrated three-division range (1 division from the top to the center horizontal graticule line).
- 7. Measure the peak-to-peak deviation, and multiply it by the demodulation sensitivity obtained in step 5 above.

Example: $0.5 \text{ div p-p signal deviation} \times 13.3 \text{ Hz/div} = 6.65 \text{ Hz Residual FM}$
_____ 20 Hz (peak-to-peak)

- 8. To measure unstabilized residual FM, repeat the test with the following control settings:

TUNING STABILIZER..... ON
 BANDWIDTH..... 1 kHz
 SCAN WIDTH..... PER DIVISION
 SCAN WIDTH PER DIVISION 1 kHz
 SCAN TIME PER DIVISION 50 MILLISECONDS

- 9. Calculate demodulation sensitivity as in steps 2 through 5. A typical value for demodulation sensitivity with the control settings given is 135 Hz/div.
- 10. Switch to ZERO scan, TUNING STABILIZER to OFF, and turn FINE TUNE so that the display occurs in the calibrated three-division range (1 division from the top, to the center horizontal graticule line).
- 11. Measure the vertical displacement and multiply it by the demodulation sensitivity obtained in step 9 above.

_____ 1 kHz (peak-to-peak)

Section IV

Table 4-3. Performance Test Record

Hewlett-Packard Model 8553B Spectrum Analyzer RF Section			Test Performed by _____		
Serial No. ____ - _____			Date _____		
Para. No.	Test Description	Measurement Units	Min	Actual	Max
4-23	Input Impedance Input Impedance, 110 MHz to 500 kHz Input Impedance, 500 kHz to 2 kHz	ohms mV	38.5	_____	65 19.0
4-24	Scan Width Accuracy 10 MHz per Division: ±3% 50 kHz per Division: ±10% 10 kHz per Division: +3%	Divisions at +3 Div. Divisions at +3 Div. Divisions at +3 Div.	+2.76	_____	+3.24 +3.8 +3.24
4-25	Tuning Dial Accuracy Frequency Accuracy				
	at 10 MHz: ± 1.0 MHz	Divisions	-1	_____	+1
	at 20 MHz: ± 1.0 MHz	Divisions	-1	_____	+1
	at 30 MHz: ± 1.0 MHz	Divisions	-1	_____	+1
	at 40 MHz: ± 1.0 MHz	Divisions	-1	_____	+1
	at 50 MHz: ± 1.0 MHz	Divisions	-1	_____	+1
	at 60 MHz: ± 1.0 MHz	Divisions	-1	_____	+1
	at 70 MHz: ± 1.0 MHz	Divisions	-1	_____	+1
	at 80 MHz: ± 1.0 MHz	Divisions	-1	_____	+1
	at 90 MHz: ± 1.0 MHz	Divisions	-1	_____	+1
	at 100 MHz: ± 1.0 MHz	Divisions	-1	_____	+1
	at 110 MHz: ± 1.0 MHz	Divisions	-1	_____	+1
	at 1 MHz: ± 0.2 MHz	Divisions	-2	_____	+2
	at 2 MHz: ± 0.2 MHz	Divisions	-2	_____	+2
	at 3 MHz: ± 0.2 MHz	Divisions	-2	_____	+2
	at 4 MHz: ± 0.2 MHz	Divisions	-2	_____	+2
	at 5 MHz: ± 0.2 MHz	Divisions	-2	_____	+2
	at 6 MHz: ± 0.2 MHz	Divisions	-2	_____	+2
	at 7 MHz: ± 0.2 MHz	Divisions	-2	_____	+2
	at 8 MHz: ± 0.2 MHz	Divisions	-2	_____	+2
	at 9 MHz: ± 0.2 MHz	Divisions	-2	_____	+2
	at 10 MHz: ± 0.2 MHz	Divisions	-2	_____	+2
	at 11 MHz: ± 0.2 MHz	Divisions	-2	_____	+2

Section IV

Table 4-3. Test Performance Record (cont'd)

Para. No.	Test Description	Measurement Units	Min	Actual	Max
4-26	Frequency Response				
	Flatness: 10 MHz - 100 MHz	Divisions	6.6	_____	7.4
	Flatness: 10 MHz	Divisions	6.6	_____	7.4
	Flatness: 1 MHz - 10 MHz	Divisions	6.6	_____	7.4
	Flatness: 100 kHz - 1 MHz	Divisions	6.6	_____	7.4
	Flatness: 10 kHz - 100 kHz	Divisions	6.6	_____	7.4
4-27	Average Noise Level				
	At 10 kHz BANDWIDTH: -110 dBm; 1-110 MHz	dBm	-110	_____	
4-28	Spurious Responses				
	-40 dBm Input Signal Levels: IM products below -110 dBm				
	19.950 MHz	dBm		_____	-110
	10.050 MHz	dBm		_____	-110
4-29	Residual Responses				
	10-110 MHz; Residual Responses down <-110 dBm	dBm	-110	_____	
	1-10 MHz; Residual Responses down <-110 dBm	dBm	-110	_____	
	200 kHz-1 MHz; Residual Responses down < --110 dBm	dBm	-110	_____	
	20-200 kHz; Residual Responses down < -95 dBm	dBm	-95	_____	
4-30	Noise Sidebands				
Noise level 50 kHz away from signal: > -70 dB	Log Div. below carrier	≥7	_____		
4-31	Local Oscillator Stability and Residual Frequency Modulation				
	Stabilized: 20 Hz peak-to-peak	Hz pk-pk		_____	20
	Unstabilized: 1 kHz peak-to-peak	kHz pk-pk		_____	1

Section V

SECTION V

ADJUSTMENTS

5-1. INTRODUCTION

5-2. This section describes adjustments required to return the analyzer RF section to peak operating condition when repairs are required. Included in this section are test setups, checks and adjustment procedures. A test card for recording data is included at the back of this section. Adjustment location photographs are contained in foldouts in Section VIII of this manual.

5-3. The adjustment procedures are arranged in numerical order. For best results, this order should be followed. Record data, taken during adjustments, in the spaces provided or in the data test card at the end of this section. Comparison of initial data with data taken during periodic adjustments assists in preventive maintenance and troubleshooting.

5-4. EQUIPMENT REQUIRED

5-5. Table 5-1 contains a tabular list of test equipment and test accessories required in the adjustment procedures. In addition, the table contains the required minimum specifications and a suggested manufacturers model number.

5-6. In addition to the test equipment and test accessories in Table 5-1, a display section and an IF section are required. When the RF and IF sections are removed from the display section, install Dummy Load Assembly A14 on rear of RF section. Perform the display section and IF section adjustments prior to performing the RF section adjustments.

5-7. Pozidriv Screwdrivers. Many screws in the instrument appear to be Phillips, but are not. The equipment required table gives the name and number of the Pozidriv screwdrivers designed to fit these screws. To avoid damage to the screw slots, the Pozidriv screwdrivers should be used.

5-8. Slug Tuning Tool. The Gowanda Model PC9668 (Hp 8710-1010) tuning tool is designed for tuning the brass slugs in the ferrite inductors used in both the IF and RF sections. No other tool should be used for this purpose.

5-9. Blade Tuning Tools. For adjustments requiring a nonmetallic metal-blade tuning tool, use the General

Cement Model No. 5003 (HP 8730-0013). It may be necessary to cut away part of the plastic on the tuning blade end to use the tool on all the adjustments. In situations not requiring nonmetallic tuning tools, an ordinary small screwdriver or other suitable tool is sufficient. No matter what tool is used, never try to force any adjustment control in the analyzer. This is especially critical when tuning variable slug-tuned inductors, and variable capacitors.

5-10. HP 11592A Service Kit. The HP 11592A Service Kit is an accessory item available from Hewlett-Packard for use in maintaining both the RF and IF sections of the spectrum analyzer. No attempt to adjust the analyzer should be made unless the user has the service kit.

5-11. Table 1-4, Accessories, contains a detailed description of the contents of the service kit.

5-12. Extender Cable Installation. Push the front panel latch in the direction indicated by the arrow until the latch disengages and pops out from the panel. Pull the plug-ins out of the instrument. Locate the black press-to-release button on the left side of the RF section. Press the button, and firmly pull the two sections apart. When the two sections separate at the front panel, raise the upper section until it is above the lower section by two or three inches at the front panel. Disengage the metal tab-slot connection at the rear and separate the sections. Remove top and bottom covers from the RF section.

5-13. Place the plate end of the HP 11592-60015 Extender Cable Assembly in the display section and press firmly into place so that the plugs make contact. The plate and plugs cannot be installed upside down as the plate has two holes corresponding to the two guide rods in the mainframe.

5-14. Connect the upper cable plug to the RF section and the lower cable plug to the IF section. The plugs are keyed so that they will go on correctly and will not make contact upside down. Connect HP 11592-60016 Interconnection Cable Assembly between the RF and IF

Section V

sections. The connectors on the cable are keyed by the shape of the plug and the arrangement of the pins. Press the connectors firmly together and extend the instruments as far apart as the cable will allow without putting stress on the connectors. Remove Dummy Load Assembly A14 from rear panel of display section and install at P4 on rear of RF section.

5-15. FACTORY SELECTED COMPONENTS

5-16. Table 5-2 contains a list of factory selected components by reference designation, basis' of selection, and schematic diagram location on which the component is illustrated. Factory selected components are designated by an asterisk (*) on the schematic diagrams in Section VIII of this manual.

5-17. RELATED ADJUSTMENTS

5-18. The following sets of adjustments are directly related. When one adjustment in a set is made, the others in that set should be checked.

5-19. Display Section Adjustments. Refer to the Display Section Operating and Service Manual.

5-20. IF Section Adjustments. Refer to the IF Section Operating and Service Manual.

5-21. RF Section Adjustments. Perform the display and IF section adjustments prior to performing the following RF section adjustments:

a. First Converter Circuits.

1. First Local Oscillator Adjustment (Para. 5-22).
2. Tuning Range Adjustment (Para. 5-23).
3. 200 MHz IF Bandpass Adjustment (Para. 5-24).

b. 150 MHz Oscillator Adjustment (Para. 5-25).

c. 120 MHz Low Pass Filter Check and Adjustment (Para. 5-26).

d. Tuning Stabilizer Circuits

1. 100 kHz Reference Oscillator Check (Para. 5-27).
2. APC Sampler Adjustment (Para. 5-28).
3. APC Search Oscillator Checks (Para. 5-29).
4. APC 100 kHz Rejection Adjustment (Para. 5-30).
5. APC Tuning Stabilizer Final Check (Para. 5-31).

Table 5-1. Recommended Test Equipment

Item	Minimum Specifications or Required Features	Suggested Model
Frequency Comb Generator	Frequency markers spaced 1, 10, 100 MHz apart; usable to 110 MHz Frequency Accuracy: +0.01% Output Amplitude: >-60 dBm	HP 8406A Comb Generator
HF Signal Generator	Frequency Range: 1-50 MHz Output Amplitude: -30 dBm Output Amplitude Accuracy: ±1% Frequency Accuracy: ±1% Output Impedance: 50 ohms	HP 606A/B HF Signal Generator
Tracking Generator	Frequency Range: 1-110 MHz Output Flatness: ± 0.5 dB over full band Output Impedance: 50 ohms Output Amplitude: at least 0 dBm (Do not substitute)	HP 8443A Tracking Generator Counter

Section V

Table 5-1. Recommended Test Equipment (cont'd)

Item	Minimum Specifications or Required Features	Suggested Model
Square-Wave Generator	Frequency Range: 10 kHz Output Amplitude: 30 V peak into 600 ohms Frequency Accuracy Waveform Symmetry: variable duty cycle Output Impedance: 600 ohms	HP 211B Square-Wave Generator
Power Supply	Output Voltage: variable, 0-13 Vdc Output Current: 0-40 mA Meter Resolution: ≥ 5 mV	HP 6217 Power Supply
Amplifier	Frequency Range: 40-60 MHz Amplifier Gain: 40 dB Input and Output Impedance: 50 ohms	HP 461A Amplifier
Frequency Counter	Frequency Range: 140-310 MHz Accuracy: $\pm 0.001\%$ Sensitivity: 100 mV rms Readout Digits: ≥ 7 digits	HP 5245L Frequency Counter with HP 5252A Plug-in
Tunable RF Voltmeter	Bandwidth: 1 kHz Frequency Range: 140-160 MHz Sensitivity: 10 mV to 1 V rms Input Impedance: ≥ 0.1 megohms	HP 8405A Vector Voltmeter
Wave Analyzer	Frequency Range: 90-110 kHz Frequency Accuracy: $\pm 2\%$ Bandwidth: 1000 Hz Voltage Accuracy: +6% of full scale Input Impedance: $> 10k$ Sensitivity: < 100 uV rms	HP 310A Wave Analyzer
Digital Voltmeter	Voltage Accuracy: $\pm 0.2\%$ Voltage Range: 1-13 Vdc full scale Input Impedance: 10 megohms Plug-in	HP 3440 Digital Voltmeter with HP 3443A Plug-in
Oscilloscope	Frequency Range: dc to 50 MHz Time Base: 1 μ s/Div to 10 ms/Div Time Base Accuracy: $\pm 3\%$ Dual Channel, Alternate Operation AC or dc coupling External Sweep Mode Voltage Accuracy Sensitivity: 0.005 V/Div	HP 180A with HP 1801A Vertical Amplifier & HP 1821A Horizontal Amplifier
50-Ohm	Tee Type N female connectors on two ports, with the third port able to accept HP 8405A probe tips.	HP 11536A 50-Ohm Tee
10-dB Fixed Attenuator	Attenuation: 10 dB ± 0.2 dB	HP 8491A, Option 10
BNC Tee	Two BNC Female Connectors, one Male BNC Connector	UG-274B/U HP 1250-0781
Adapter	BNC Male to Type N Female	UG-349A/U HP 1250-0077

Section V

Table 5-1. Recommended Test Equipment (cont'd)

Item	Minimum Specifications or Required Features	Suggested Model
Adapter (2)	BNC Female to Type N Male	UG-201A/U HP 1250-0780
Test Fixture	See Table 1-4	
Voltage Probe	Dual Banana Plug to Probe Tip and Clip (Ground) Lead	HP 10025A Straight-Thru Voltage Probe
Cable Assy (3)	Male BNC Connectors, 48 inches long	HP 10503A
Service Kit	See Table 1-4	HP 11592A
Three-port Mixer	Frequency Range: 40-150 MHz Impedance: 50 ohms Connectors: Female BNC on all ports Input Power: 5 mW nominal	HP 10514A Mixer
Cable Assembly	Dual Banana Plug to Clip Leads, 45 inches long	HP 11002A
Cable Assembly	Dual Banana Plug to Dual Banana Plug, 44 inches long	HP 11000A
Cable Assembly	BNC Male to one end only; 44 inches long. (Attach Test Clips to Shield and Center Conductor.)	HP 10501A
Tuning Tool, Blade	Nonmetallic Shaft, 6 inches long	Gen.Cement 5003 HP 8730-0013
Tuning Tool, Slot	Nonmetallic, 6-inch shaft	Gowanda PC-9668 HP 8710-1010
Wrench	Open-end, 15/64 inch HP 8710-0946	
Screwdrivers	Phillips No. 1 and 2 Pozidriv No. 1 (Small) Stanley No. 5331 Pozidriv No. 2 (Medium) Stanley No. 5332	HP 8710-0899 HP 8710-0900
Tuning Tool, Slot	Nonmetallic, 2.5 inch shaft	HP 8710-0095
Adapter	Type N to BNC Female Adapter	FXR 21850

Table 5-2. Factory Selected Components

Component	Service Sheet	Basis of Selection
A5A1R32, R33, R34, R38, R39, R42, R44, R45, R48, R51, R54, R57, R60, R63, R66	8	Selected to provide voltage shaping for first LO tuning. Fixed resistors selected to center tuning range of associated variable resistors
A6A1R8	6	Selected for compatibility with step-recovery diode A6A1CR8.
A7A1R2, A7AIR19 A7A1R28 A7A1R17	5	Selected to optimize adjustment range of A7A1R3 Selected to set output level of first LO. Selected to compensate for differences in tank circuit components. Selected to optimize VTO output flatness.
A8A1R11	7	Selected for period adjustment in the divide-by-five circuit.
A9A1C8 A9A1R7 A9A2C2	4	Selected to adjust 200 MHz Ampl. gain to 14 dB. Selected for maximum flatness of 200 MHz bandpass filters. Selected to optimize flatness of first mixer.
A10A1L4 A10A1R5	9	Selected for crystal compatibility with other 150 MHz oscil. components Selected to provide gain compensation.

ADJUSTMENT PROCEDURES

5-22. First Local Oscillator Adjustment

REFERENCE: Service Sheets 5, 8.

DESCRIPTION:

After the display and IF sections are adjusted, the first local oscillator is adjusted on the 0-110 MHz range. Adjustments are first made at the end points of the frequency dial and then the midpoints are adjusted in 10 MHz increments. The 0-11 MHz range is selected and the frequency is adjusted at the 0 and 11 MHz points.

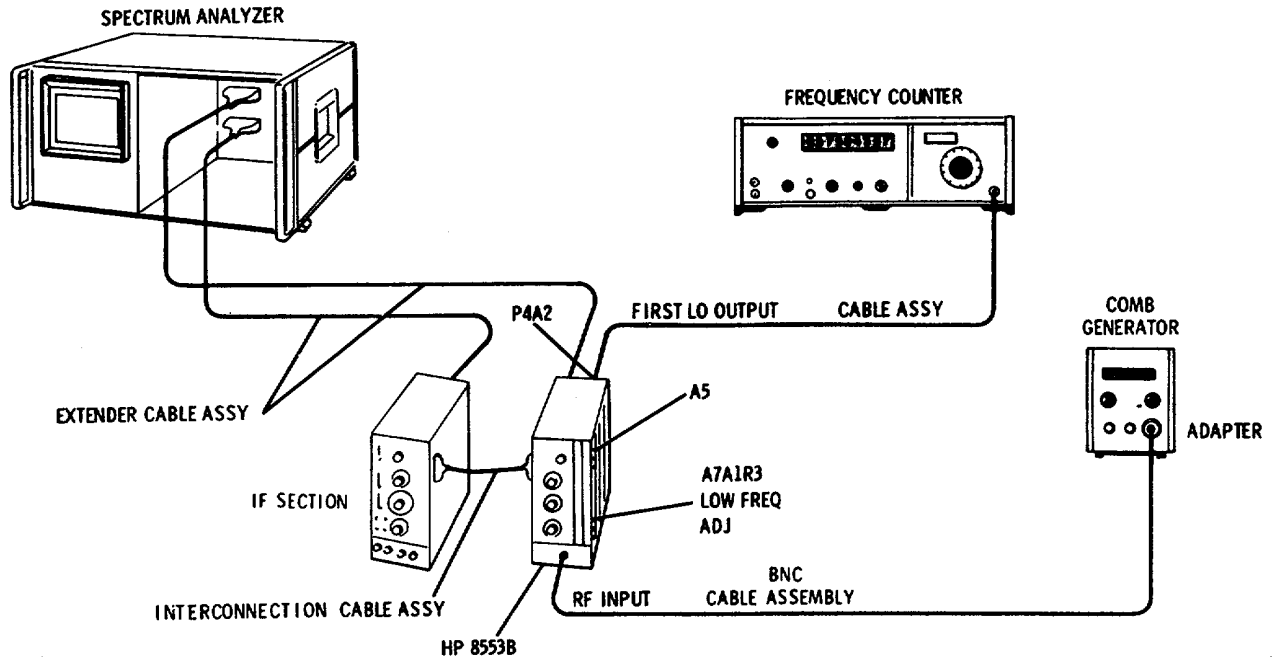

Figure 5-1. First Local Oscillator Adjustment Test Setup

EQUIPMENT:

Comb Generator	HP 8406A
Frequency Counter with 5252A Plug-in	HP 5245L
BNC Cable Assembly.....	HP 10503A
Type N male-to-BNC female Adapter.....	UG-201A/U
Extender Cable Assembly.....	HP 11592-60015
Interconnection Cable Assembly	HP 11592-60016
Cable Assembly.....	HP 11592-60013

1. Connect the setup in Figure 5-1. Make the following control settings:

ANALYZER:

RANGE MHz	0-110
FREQUENCY	0 MHz
FINE TUNE.....	Centered
BANDWIDTH.....	30 kHz
SCAN WIDTH.....	PER DIVISION
SCAN WIDTH PER DIVISION	1 MHz
INPUT ATTENUATION.....	10 dB

ADJUSTMENT PROCEDURES (cont'd)

5-22. First Local Oscillator Adjustment (cont'd)

ANALYZER Control Settings (cont'd)

BASE LINE CLIPPER CCW
 SCAN TIME PER DIVISION 2 MILLISECONDS
 LOG REF LEVEL -10 dBm
 LOG REF LEVEL Vernier CCW
 LOG-LINEAR LOG
 VIDEO FILTER OFF
 SCAN MODE INT
 SCAN TRIGGER AUTO

8406A:

COMB FREQUENCY - MC 10 MC
 INTERPOLATION AMPLITUDE OFF
 OUTPUT AMPLITUDE 3 o'clock

5245L/5252A:

SAMPLE RATE 8 o'clock
 SENSITIVITY PLUG IN
 TIME BASE 10 ms
 FUNCTION FREQUENCY
 MAX COUNT RATE 350 MHz

2. Center dial pointer on 0 MHz using FREQUENCY control.
3. Select ZERO SCAN WIDTH, and center TUNING RANGE Adjust A5A1R13.
4. Adjust A7A1R3 LOW FREQ ADJ in the 8553B for maximum base line lift. (In ZERO SCAN WIDTH base line lift is an indication that signals are present.)
5. Turn FREQUENCY to 110 MHz. The counter should read 310 MHz ± 10 MHz.

300 ___ 320 MHz

6. Turn SCAN WIDTH to PER DIVISION. Turn FREQUENCY to 5 MHz. The local oscillator feedthrough signal should appear on the left edge of the graticule.
7. Tune FREQUENCY until half the feedthrough signal appears at the left edge of the graticule. See Figure 5-2.
8. Adjust A5A1R32 until half the comb signal appears at the right edge of the graticule. Readjust FINE TUNE and A5A1R32 as necessary until half of each signal appears on the edges of the graticule.
9. Select ZERO SCAN WIDTH. Measure the first local oscillator frequency. The frequency should be 205 ± 0.5 MHz.

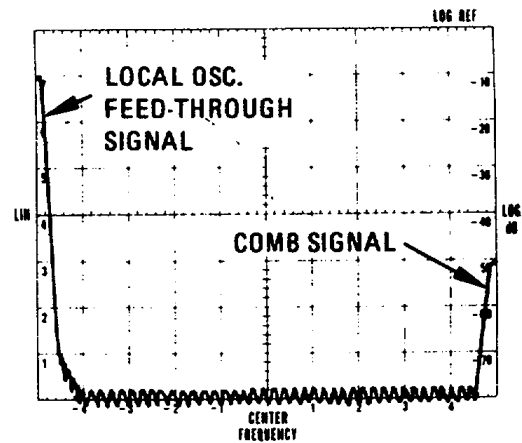

Figure 5-2. First Local Oscillator Adjustment: CRT Display

10. Select SCAN WIDTH PER DIVISION. Change the comb generator COMB FREQUENCY MC to 1 MC.
11. The comb spectrum should be evenly distributed across the graticule. The center comb should be on the center graticule ± 0.3 divisions (300 kHz).
12. Return the comb generator to the 10-MC comb.

ADJUSTMENT PROCEDURES (cont'd)

5-22. First Local Oscillator Adjustment (cont'd)

13. Repeat the alignment procedure at each of the adjustment points listed in Table 5-3 below. At each adjustment point, set FREQUENCY so that comb signal appears at the left edge of the graticule. Adjust the potentiometers so that the signal on the right-hand edge is half visible. Use FINE TUNE to keep the left-hand signal half visible during the adjustment.
14. Repeat the adjustment until the left-hand signal is half visible and the right-hand edge is half visible.

Table 5-3. First Local Oscillator Adjustments

Approximate Dial Frequency	Approximate First Local Oscillator Frequency	Adjust
0 MHz	200 MHz	A7A1R3 (LOW FREQ ADJ)
110 MHz	310 MHz	
5 MHz	205 MHz	A5A1R32 10
15 MHz	215 MHz	A5A1R38 20
25 MHz	225 MHz	A5A1R41 30
35 MHz	235 MHz	A5A1R44 40
45 MHz	245 MHz	A5A1R47 50
55 MHz	255 MHz	A5A1R50 60
65 MHz	265 MHz	A5A1R53 70
75 MHz	275 MHz	A5A1R56 80
85 MHz	285 MHz	A5A1R59 90
95 MHz	295 MHz	A5A1R62 100
105 MHz	305 MHz	A5A1R65 110

15. Switch RANGE MHz to 0-11 with FINE TUNE control centered and repeat steps 2 and 3 above.
16. Change the comb generator to 1 MC and adjust A13R5 11 MHz low freq adj for maximum base line lift.
17. Turn FREQUENCY to 11 MHz and adjust A13R2 for maximum base line lift.
18. Turn FREQUENCY to 0 MHz and repeat adjustments in steps 16 and 17.
19. Select 1 MHz SCAN WIDTH PER DIVISION. The comb spectrum should be evenly distributed across the CRT with a 1 MHz marker within +0.2 divisions (200 kHz) of each vertical graticule line.

ADJUSTMENT PROCEDURES (cont'd)

5-23. Tuning Range Adjustment

REFERENCE: Service Sheets 5, 8.

DESCRIPTION: After the first local oscillator has been adjusted, the tuning range is adjusted as a fine-tune step by aligning the dial to 0 and 100 MHz. Intermediate points are then checked.

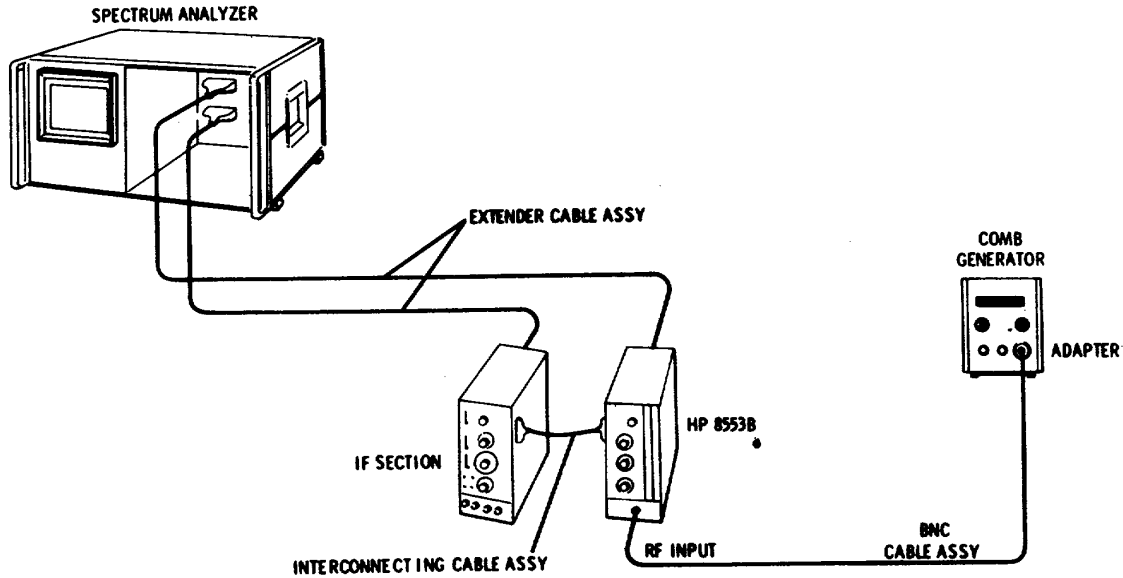

Figure 5-3. Tuning Range Adjustment Test Setup

EQUIPMENT:

Comb Generator	HP 8406A
Type N Male-to-BNC Female Adapter	UG-201A/U
Interconnecting Cable Assembly	HP 11592-60016
BNC Cable Assembly	HP 10503A
Extender Cable Assembly	HP 11592-60015

1. Connect the setup in Figure 5-3. Make the following control settings:

ANALYZER:

RANGE MHz	0-110
FREQUENCY	100 MHz
FINE TUNE	Centered
BANDWIDTH	10 kHz
SCAN WIDTH	PER DIVISION
SCAN WIDTH PER DIVISION	0.2 MHz
TUNING STABILIZER	OFF
INPUT ATTENUATION	10 dB
SCAN TIME PER DIVISION	5 MILLISECONDS
LOG REF LEVEL Controls	-20 dBm
LOG/LINEAR	LOG
BASE LINE CLIPPER	Max ccw

ADJUSTMENT PROCEDURES (cont'd)

5-23. Tuning Range Adjustment (cont'd)

ANALYZER Control Settings (cont'd)

SCAN MODE INT
 SCAN TRIGGER LINE

8406A

COMB FREQUENCY -MC 100 MC
 INTERPOLATION AMPLITUDE OFF
 OUTPUT AMPLITUDE 3 o'clock

2. Center FINE TUNE. Adjust FREQUENCY until dial pointer is centered on 100 MHz.
3. Adjust A6A1R13 TUNING RANGE so that 100 MHz comb signal is directly over graticule line.
4. Select the 10 MC COMB FREQUENCY on the 8406A.
5. Tune the analyzer FREQUENCY control across the band. Go from 100 MHz down to 0 MHz stopping at 10 MHz increments. The comb signals should be aligned with the center frequency mark on the display ± 5 divisions (1 MHz).
-5 _____ +5 Div
6. At 0 MHz, a slight adjustment of A7A1R3, LOW FREQ ADJ, will bring the local oscillator feedthrough signal to the center of the display.
7. Retune FREQUENCY to 100 MHz. If necessary, readjust A5A1R13 to center the display.
8. Tune FREQUENCY to 90 MHz. The display should be centered ± 5 divisions (1 MHz).
9. Set FREQUENCY to 50 MHz, BANDWIDTH to 300 kHz, and SCAN WIDTH PER DIVISION to 10 MHz.
10. Turn FREQUENCY until the 50 MHz comb signal is exactly on the center graticule.
11. Set SCAN WIDTH to 0-100 MHz.
12. Adjust A4R7 SCAN ADJ on the A4 Scan Assembly until the 50 MHz comb signal is exactly on the center graticule.
13. Set the BANDWIDTH to 10 kHz, SCAN WIDTH PER DIVISION to 0.1 MHz and turn FREQUENCY to dip the 50 MHz comb signal.
14. Switch SCAN WIDTH to PER DIVISION. The 50 MHz comb should be centered t 4 divisions (+400 kHz).
-4 _____ +4 Div

ADJUSTMENT PROCEDURES (cont'd)

5-24. 200 MHz IF Bandpass Adjustment

REFERENCE: Service Sheet 3

DESCRIPTION: A fixed signal is connected to the RF INPUT while sweeping the 200 MHz IF circuits using the first local oscillator. The second converter is bypassed and replaced with an external mixer also swept by the first local oscillator. The swept 200 MHz passband is detected with the analyzer display and adjusted for best passband shape.

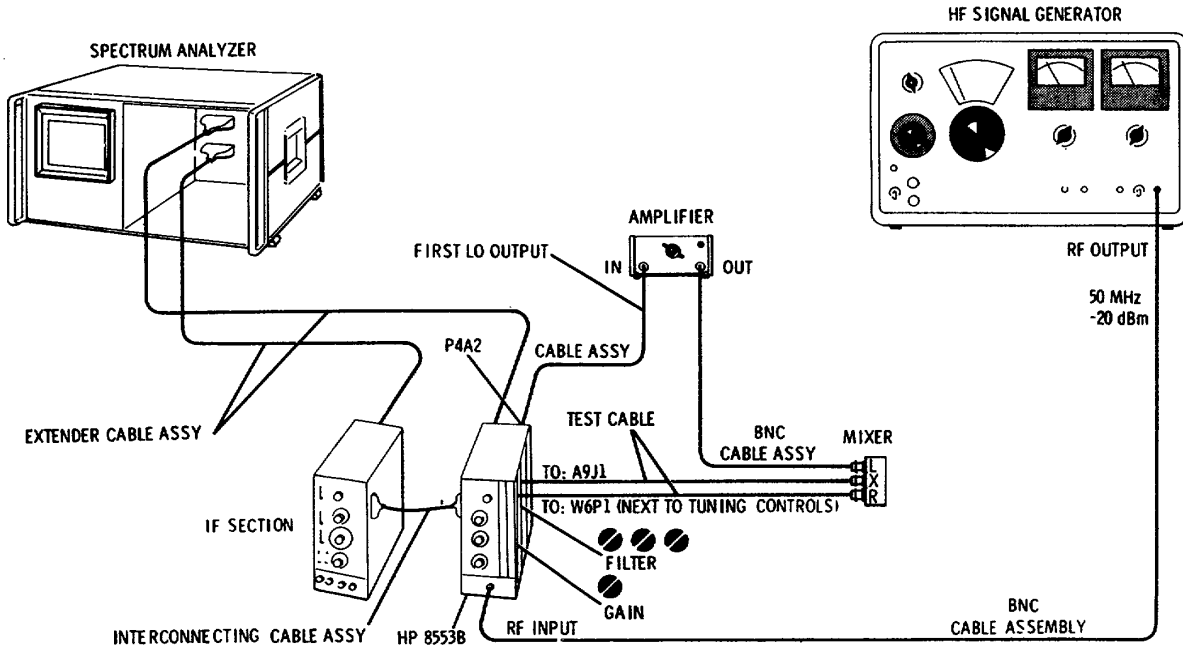

Figure 5-4. 200 MHz IF Bandpass Adjustment Test Setup

EQUIPMENT:

Signal Generator.....	HP 606B
Amplifier	HP 461A
Mixer	HP 10514A
Extender Cable Assembly.....	HP 11592-60015
Interconnecting Cable Assembly.....	HP 11592-60016
Test Cable (2).....	HP 11592-60001
BNC Cable Assembly (2)	HP 10503A
Cable Assembly (1).....	HP 11592-60013

1. Connect the test setup in Figure 5-4 and make the following control settings:

ANALYZER:

RANGE MHz	0-110
FREQUENCY	50 MHz
FINE TUNE.....	Centered
BANDWIDTH.....	300 kHz

ADJUSTMENT PROCEDURES (cont'd)

5-24. 200 MHz IF Bandpass Adjustment (cont'd)

ANALYZER Control Settings (cont'd)

SCAN WIDTH.....	PER DIVISION
SCAN WIDTH PER DIVISION.....	10 MHz
INPUT ATTENUATION.....	10 dB
BASE LINE CLIPPER.....	Max ccw
SCAN TIME PER DIVISION.....	2 MILLISECONDS
LOG/LINEAR.....	LOG
LOG REF LEVEL.....	-20 dBm
VIDEO FILTER.....	10 kHz
SCAN MODE.....	INT
SCAN TRIGGER.....	AUTO

606B:

FREQUENCY.....	50 MHz
MODULATION.....	CW
ATTENUATION -dBm.....	- 30

461A:

- GAIN (DB) 40
- 2. Tune the HP 606B Signal Generator for maximum signal display on the analyzer.
- 3. Adjust LOG REF LEVEL Vernier for full scale deflection.
- 4. The upper bandpass skirt should be at least 30 MHz (+3 graticule line) away from CENTER FREQUENCY 50 dB down.
Upper Bandpass: ____ 50 dB
- 5. Set SCAN WIDTH PER DIVISION to 2 MHz; LOG/LINEAR to LINEAR.
- 6. Set LINEAR SENSITIVITY controls so that the displayed bandpass amplitude is 7 divisions.

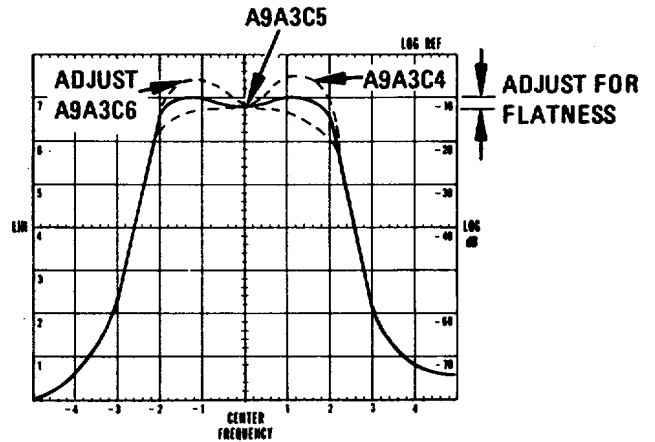

Figure 5-5. 200 MHz Bandpass Shape Adjustment: CRT Display

- 7. Measure total deviation of the bandpass flatness; flatness should be within +0.4 divisions (vertical) over ±1 divisions (horizontal) referenced from CENTER FREQUENCY. Compare the display with Figure 5-5.
-0.4 _____ +0.4 Div
- 8. If display flatness is within tolerance, no adjustment is necessary. If not, adjust as in steps 9 through 12.
- 9. Center AMPL CAL; set LINEAR SENSITIVITY to 1 mV/DIV; LINEAR SENSITIVITY Vernier to 1.
- 10. Turn all three bandpass adjustments on the A9 assembly marked FILTER fully clockwise. Be careful not to damage the capacitors.
- 11. Turn the outer FILTER adjustments, A9A3C6 and A9A3C4 ten turns counterclockwise; turn the center FILTER adjustment A9A3C5 three turns counterclockwise.
- 12. Adjust the FILTER adjustments, A9A3C4,5,6 for a bandpass shape as shown in Figure 5-5 while maintaining amplitude at 7 divisions using GAIN adjust A9A1C8. If sufficient amplitude cannot be obtained with A9A1C8, change the value of factory selected resistor, A9A1R7 until proper level is achieved.

ADJUSTMENT PROCEDURES (cont'd)

5-25. 150 MHz Oscillator Adjustment

REFERENCE: Service Sheet 9.

DESCRIPTION: The 150 MHz oscillator is adjusted with a nonmetallic screwdriver to 150 MHz \pm 10 kHz. the specified operating frequency, output amplitude of the oscillator should be 150 to 230 millivolts rm During the adjustment caution must be used to avoid damaging the tuning slug.

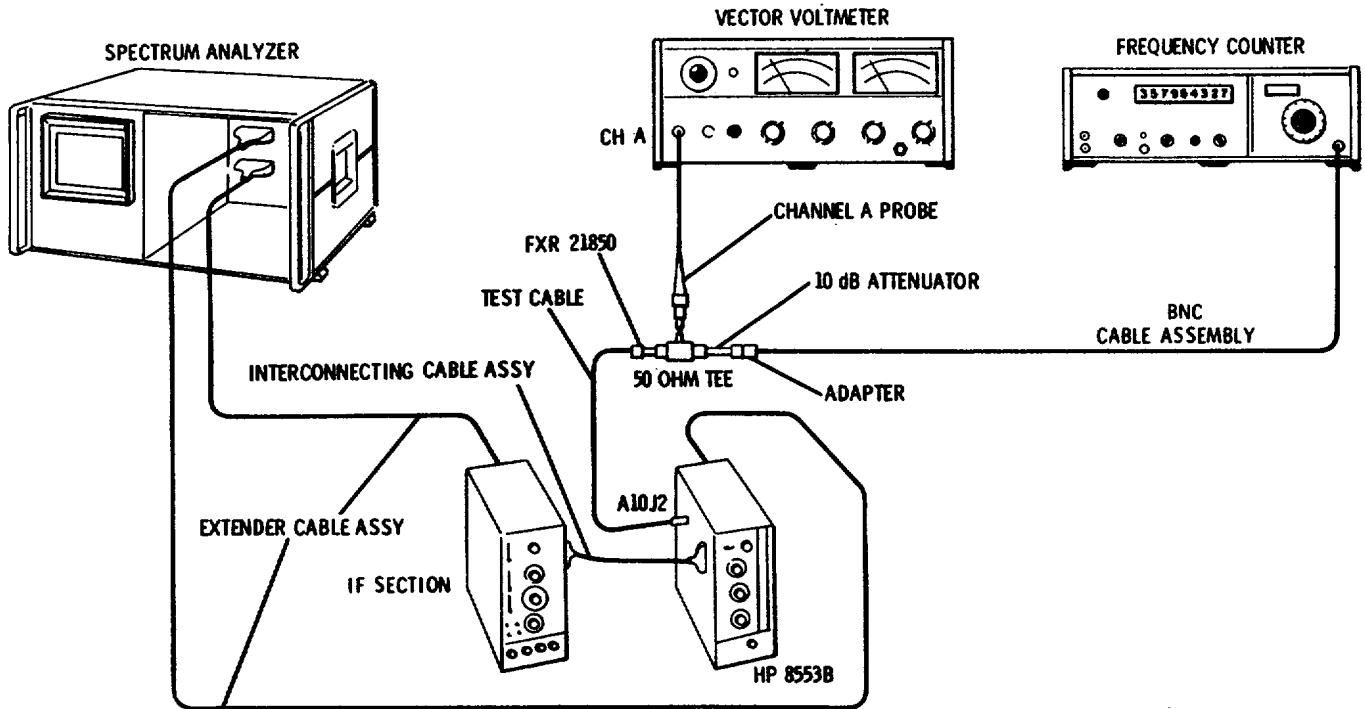

Figure 5-6. 150 MHz Oscillator Adjustment Test Setup

EQUIPMENT:

Vector Voltmeter	HP 8405A
Frequency Counter	HP 5245L/5252A
Extender Cable Assembly	HP 11592-60015
Interconnecting Cable Assembly	HP 11592-60016
Cable Assembly	HP 11592-60001
BNC Cable Assembly	HP 10503A
50-Ohm Tee	HP 11536A
Adapter, Male Type N to BNC Female	UG-201A/U
10 dB Attenuator Pad	HP 8491A
Nonmetallic Tuning Tool	
Type N Female to BNC Female Adapter	FXR 21850

1. Connect test setup in Figure 5-6. Make the following control settings.

ANALYZER:

RANGE MHz	0-110
FREQUENCY	0 MHz

ADJUSTMENT PROCEDURES (cont'd)

5-25. 150 MHz Oscillator Adjustment (cont'd)

ANALYZER Control Settings (cont'd)

FINE TUNE.....	Centered
BANDWIDTH.....	10 kHz
SCAN WIDTH.....	PER DIVISION
SCAN WIDTH PER DIVISION	0.1 MHz
INPUT ATTENUATION.....	10 dB
BASE LINE CLIPPER.....	Max ccw
SCAN TIME PER DIVISION	2 MILLISECONDS
LOG REF LEVEL.....	0 dBm
LOG REF LEVEL Vernier.....	0
VIDEO FILTER.....	OFF
SCAN MODE.....	INT
SCAN TRIGGER	AUTO
LOG/LINEAR.....	LOG

8405A:

FREQUENCY RANGE - MHz	100-200
CHANNEL	A
AMPLITUDE RANGE.....	300 mV

5245L/5252A:

SAMPLE RATE.....	8 o'clock
SENSITIVITY.....	PLUG IN
TIME BASE	10 ms
FUNCTION.....	FREQUENCY
MAX COUNT RATE.....	200 MC

2. Tune FREQUENCY to center local oscillator feedthrough signal on the analyzer display.
3. Use a nonmetallic tuning tool to tune A10A1L3. See component location illustration in Section VIII for the location of A10A1L3 (top of 8553B).
4. Turn A10A1L3 counterclockwise until the local oscillator feedthrough signal no longer appears on the display.

CAUTION

Excess turning pressure may damage the tuning slug. Do not attempt to force the slug, or to turn it any further than necessary.

5. Turn the slug clockwise for a peak amplitude indication on the vector voltmeter.
6. Carefully turn the slug until the oscillator frequency is 150 MHz \pm 10 kHz, as indicated on the frequency counter.

149.990 _____ 150.010 MHz

Oscillator output amplitude should be between 150 and 250 mV rms into a 50-ohm load. The 11536A Probe Tee and 10 dB pad provides a 50-ohm termination.

150 _____ 250 mV rms.

ADJUSTMENT PROCEDURES (cont'd)

5-26. 120 MHz Low Pass Filter Check and Adjustment

REFERENCE: Service Sheet 3.

DESCRIPTION: 120 MHz low-pass filter pass band response may be checked using frequency response test 4-24. The 120 MHz low-pass filter is adjusted for flatness between 30 and 110 MHz using the HP 8443A Tracking Generator/Counter as a leveled tracking source. By connecting the spectrum analyzer (P4) to the Tracking Generator/Counter, the Tracking Generator frequency range is synchronized to the analyzer first local oscillator. (The analyzer and the tracking generator track the same frequency range, allowing a swept view of the 120 MHz bandpass shape.)

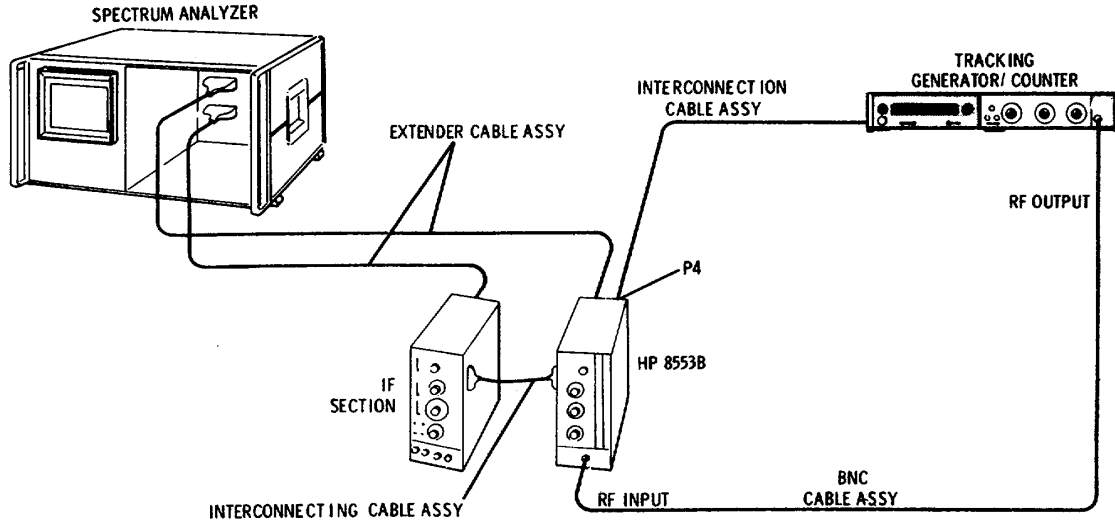

Figure 5-7. 120 MHz Low Pass Filter Adjustment Test Setup

EQUIPMENT:

Tracking Generator/Counter.....	HP 8443A
BNC Cable Assembly.....	HP 10503A
Extender Cable Assembly.....	HP 11592-60015
Nonmetallic Tuning Tool	HP 8730-0013
Interconnecting Cable Assembly	HP 11592-60016
Cable Assembly.....	HP 11592-60013
Interconnection Cable Assembly	HP 08443-60049

1. Connect the test setup in Figure 5-7 and make the following control settings:

ANALYZER:

RANGE MHz	0-110
FREQUENCY	80 MHz
FINE TUNE.....	centered -
INPUT ATTENUATION.....	10 dB
BANDWIDTH.....	300 kHz
SCAN WIDTH.....	PER DIVISION
SCAN WIDTH PER DIVISION	10 MHz
LOG/LINEAR	LOG

ADJUSTMENT PROCEDURES (cont'd)

5-26. 120 MHz Low Pass Filter Check and Adjustment (cont'd)

ANALYZER Control Settings (cont'd)

LOG REF LEVEL..... +10 dBm
 VIDEO FILTER..... 10 kHz
 SCAN MODE..... INT
 SCAN TRIGGER..... AUTO
 SCAN TIME PER DIVISION..... 5 MILLISECONDS

2. Set the Tracking Generator/Counter controls as follows:

8443A:

OUTPUT LEVEL dBm..... 0
 MODE..... Marker
 RESOLUTION..... 100 Hz

3. Peak the response on the analyzer CRT using FINE TUNE. Maximum amplitude should be within 2 divisions of full scale.
4. Change INPUT ATTENUATION to 30 dB. Switch the LOG/LINEAR control to LINEAR. Adjust LINEAR SENSITIVITY so that trace is centered on the 6-LIN line (left side of graticule). Figure 5-8 shows limits for the filter response in divisions.

120 MHz LPF Flatness, 30-100 MHz:
 5.5 _____ 6.5 Div

120 MHz LPF Roll-off between 110 MHz and 125 MHz:
 1 Div _____

5. If the filter is not within the limits in step 4, adjust A11L1, 2, 3, and 4.

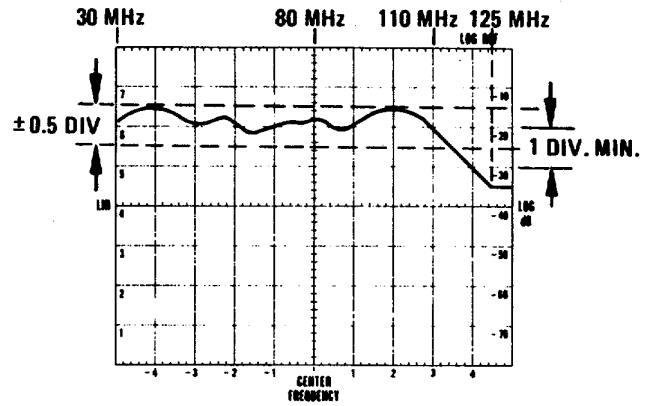

Figure 5-8. 120 MHz Bandpass Shape

ADJUSTMENT PROCEDURES (cont'd)

5-27. 100 kHz Reference Oscillator Check

REFERENCE: Service Sheet 7.

DESCRIPTION: An external power supply is connected to the 100 kHz reference oscillator. The supply is varied to check the frequency stability.

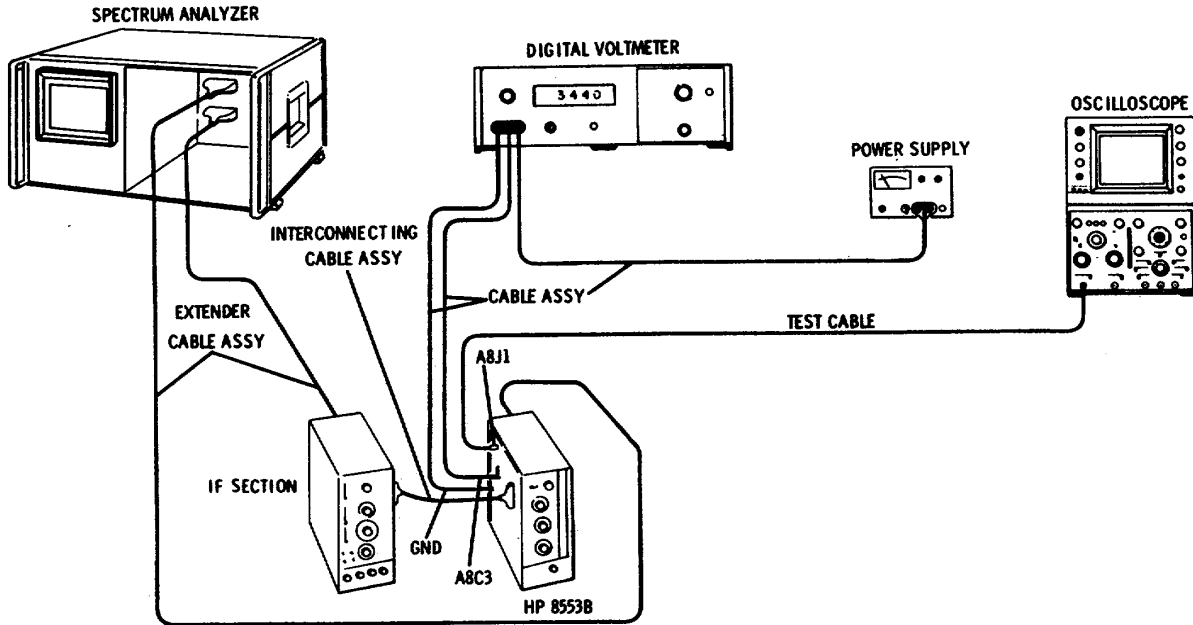

Figure 5-9. 100 kHz Reference Oscillator Check Test Setup

EQUIPMENT:

Oscilloscope	HP 180A/1801A/1821A
Digital Voltmeter	HP 3440A/3443A
Power Supply.....	HP 6217A
Test Cable	HP 11592-60001
Cable Assembly.....	HP 11000A
Cable Assembly.....	HP 11002A
Extender Cable Assembly.....	HP 11592-60015
Interconnecting Cable Assembly.....	HP 11592-60016

1. Connect the setup in Figure 5-9 and make the following control settings:

ANALYZER:

RANGE MHz	0-110
SCAN WIDTH.....	PER DIVISION
SCAN WIDTH PER DIVISION	20 kHz
TUNING STABILIZER.....	On

ADJUSTMENT PROCEDURES (cont'd)

5-27. 100 kHz Reference Oscillator Check (cont'd)

180A/1801A/1821A:

VERTICAL SCALE..... 1 VOLT/DIV
 SWEEP TIME 5μSEC/DIV
 INPUT..... DC

6217A:

VOLTAGE -12.6 VDC

2. Disconnect the -12.6 Vdc lead from A8C3. Connect the 6217A Power Supply to A8C3. 2 U SEC/DIV Set the output voltage to -12.6 Vdc.
3. Disconnect the 11592-60003 RF cable from A8J1. Connect the white BNC-to-Selectro test cable between A8J1 and the oscilloscope.
4. Measure the 100 kHz output signal. See Figure 5-10. Output amplitude should be 6.0 +0.4 volts peak-to-peak. Period of the waveform should be 10 +0.5 μseconds.

Amplitude: 5.6 _____ 6.4 V p-p
 Period: 9.5 _____ 10.5 μs

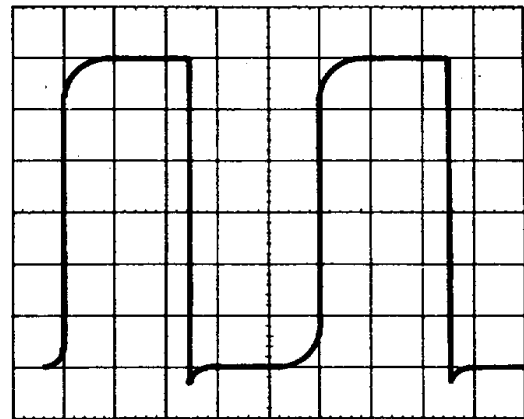

Figure 5-10. Reference Oscillator Output Measurement

5. Vary the power supply voltage between -10.5 and -14.5 Vdc while monitoring output on the digital voltmeter. The 100 kHz oscillator should maintain a period of 9.5 μ to 10.5 μs as listed in step 4.
6. Disconnect the power supply from A8C3. Reconnect the analyzer -12.6 Vdc supply to A8C3.
7. Check amplitude and waveform period as in step 4.

9.5 _____ 10.5 μs

Amplitude: 5.6 _____ 6.4 V p-p
 Period: 9.5 _____ 10.5 μs

ADJUSTMENT PROCEDURES (cont'd)

5-28. APC Sampler Adjustment

REFERENCE: Service Sheet 6.

DESCRIPTION: A 10 kHz square-wave input is substituted for the 200-310 MHz local oscillator signal. The APC sample is adjusted for sampling efficiency and dc-balance. Sampling efficiency is adjusted by observing a sampling waveform on top of the 10 kHz waveform, and adjusting the second and third samples for equal amplitude.

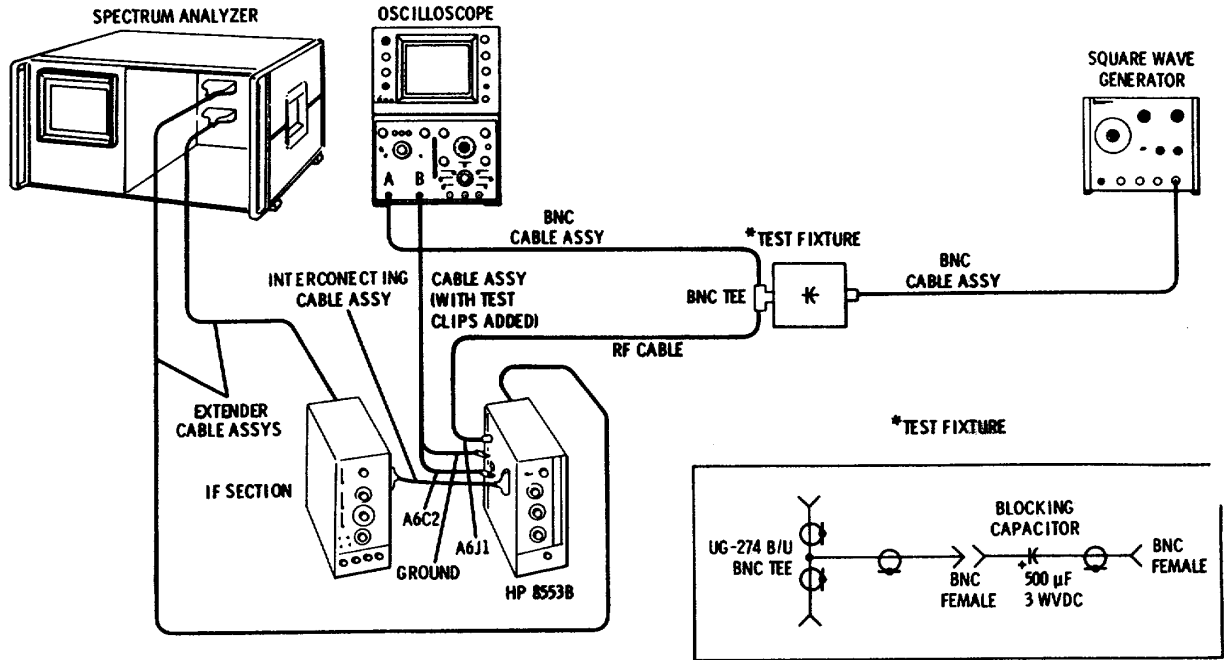

Figure 5-11. APC Sampler Adjustment Test Setup.

EQUIPMENT:

Oscilloscope	HP 180A/1801A/1821A
Square Wave Generator	HP 211B
Extender Cable Assembly	HP 11592-60015
Interconnecting Cable Assembly	HP 11592-60016
BNC Cable Assembly (2)	HP 10503A
RF Test Cable.....	HP 11592-60001
Cable Assembly (with test clips added).....	HP 10501A
Test Fixture: BNC Tee	UG-274B/U
Blocking Capacitor, 500 uF, 3W Vdc.....	HP 0180-1734
BNC Female Connector (2).....	HP 1250-0083

1. Connect the test setup in Figure 5-11. Set the controls as follows:

ANALYZER:

RANGE MHz	0-110
TUNING STABILIZER.....	On
BANDWIDTH.....	3 kHz
SCAN WIDTH.....	PER DIVISION

ADJUSTMENT PROCEDURES (cont'd)

5-28. APC Sampler Adjustment (cont'd)

ANALYZER Control Settings (cont'd)

SCAN WIDTH PER DIVISION 20 kHz
 SCAN TIME PER DIVISION 10 MILLISECONDS
 A6 APC SEARCH TEST

180A/1801A/1821A:

VERTICAL SCALE
 Channel A 0.2 VOLTS/DIV
 Channel B 0.1 VOLTS/DIV
 VERTICAL COUPLING DC
 HORIZONTAL SCALE 10 μS/DIV
 TRIGGER INTERNAL

211B:

FREQUENCY (Hz) 10
 MULTIPLIER 1K
 SYMMETRY Centered
 AMPLITUDE (V ACROSS 50 Ohms) 5

2. Dc-balance oscilloscope Channels A and B. Set the base lines to the center horizontal graticule line. Switch the input to Channel A.
3. Adjust the square-wave generator AMPLITUDE and SYMMETRY controls for a symmetrical, 0.8 volt peak-to-peak square wave.
4. Switch the oscilloscope to Channel B. Adjust the square-wave generator FREQUENCY and SYMMETRY controls, and the oscilloscope TRIGGER control for a steady, single waveform as shown in Figure 5-12.
5. Dc-balance the waveform by adjusting A6A1R13, the sampler BIAS adjust. The waveform should be balanced to zero volts ±0.3 volts.

-0.3 _____ +0.3V

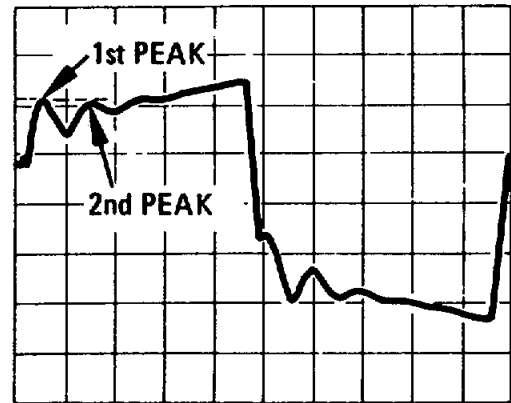

Figure 5-12. APC Sampler Adjustment.

6. Adjust A6A1C16, the sampler Efficiency Adjust, until the first and second peaks are equal in amplitude.
 Sampler Efficiency _____(v)
7. Recheck the oscilloscope dc balance, and then reset the sampler bias adjust as in step 5, if necessary.
8. Set A6 APC SEARCH to NORMAL.

ADJUSTMENT PROCEDURES (cont'd)

5-29. APC Search Oscillator Checks

REFERENCE: Service Sheet 6.

DESCRIPTION: The first local oscillator signal is disconnected from the APC input at A6C1. The search oscillator output is monitored while varying the test conditions to verify the search oscillator operation.

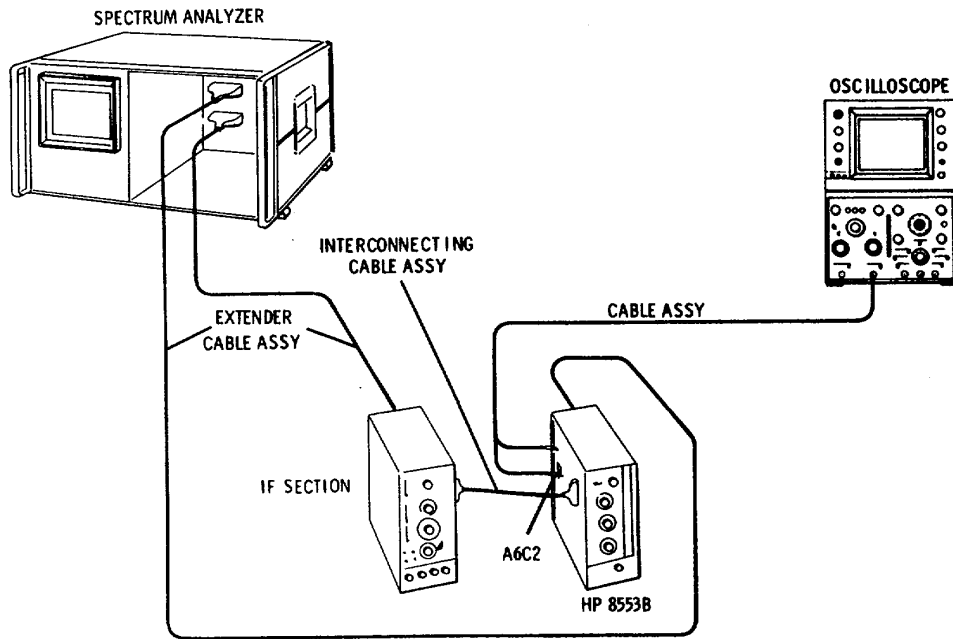

Figure 5-13. APC Search Oscillator Check Test Setup.

EQUIPMENT:

Oscilloscope	HP 180A/1801A/1821A
Cable Assembly (with test clips added)	HP 10501A
Extender Cable Assembly	HP 11592-60015
Interconnecting Cable Assembly	HP 11592-60016

1. Connect the test setup in Figure 5-13 and make the following control settings:

ANALYZER:

RANGE MHz	0-110
TUNING STABILIZER.....	ON
A6 APC SEARCH	NORMAL
SCAN WIDTH.....	PER DIVISION
SCAN WIDTH PER DIVISION	20 kHz

180A/1801A/1821A:

HORIZONTAL SCALE	20 ms/DIV
VERTICAL SCALE.....	0.5 VOLTS/DIV
VERTICAL COUPLING.....	AC

ADJUSTMENT PROCEDURES (cont'd)

5-29. APC Search Oscillator Checks (cont'd)

2. Dc-balance the oscilloscope, and set the base line at the center horizontal graticule.
3. Disconnect the lead from A6C1. Connect the oscilloscope input to A6C2.
4. Measure the waveform that appears at A6C2. Amplitude should be between 2.0 and 2.8 volts, peak-to-peak. Waveform period should be 100 ms \pm 25 ms.

Amplitude: 2.0 _____ 2.8 volts p-p

Period: 75 _____ 125 ms

5. Reconnect the green lead to A6C1.
6. Set the oscilloscope horizontal scale to 1 second per division. Monitor A6C2 while slowly turning the analyzer FREQUENCY control.
7. As FREQUENCY is tuned slowly across the dial, the voltage at A6C2 should be 1.5 \pm 0.2 volts peak-to-peak.

1.3 _____ 1.7 volts p-p

5-30. APC 100 kHz Rejection Adjustment

REFERENCE: Service Sheet 6.

DESCRIPTION: The APC search voltage output is monitored while adjusting the rejection control for minimum 100 kHz signal.

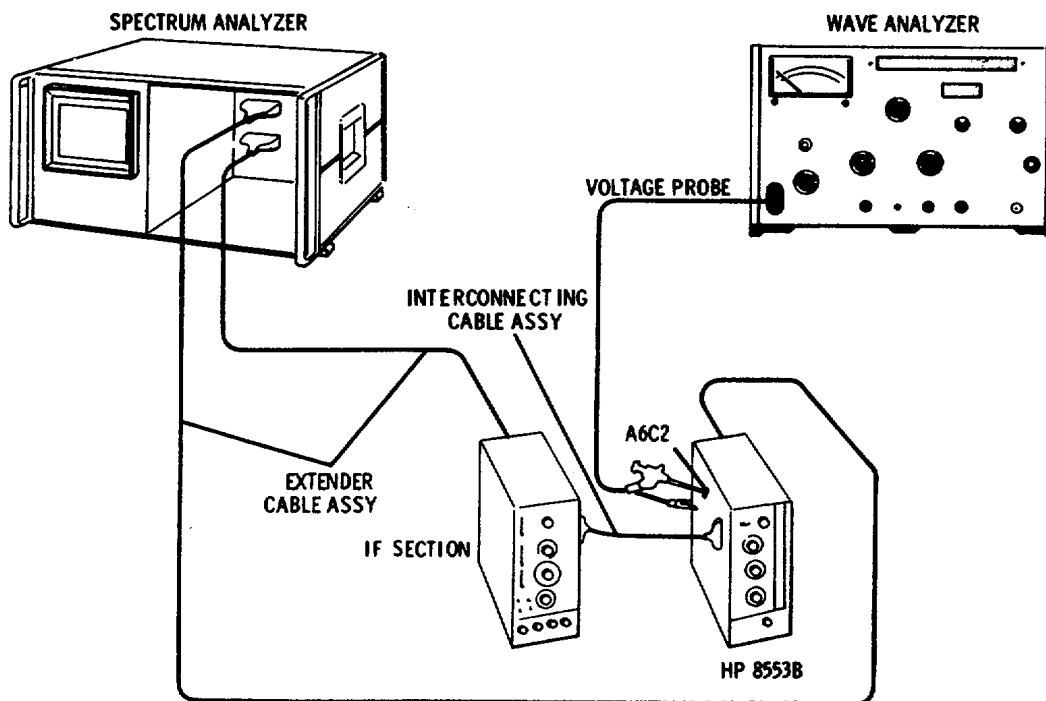

Figure 5-14. APC 100 kHz Rejection Adjustment Test Setup

ADJUSTMENT PROCEDURES (cont'd)

5-30. APC 100 kHz Rejection Adjustment (cont'd)

EQUIPMENT:

Wave Analyzer	HP 310A
Straight-through Voltage Probe	HP 10025A
Extender Cable Assembly	HP 11592-60015
Interconnecting Cable Assembly	HP 11592-60016

ANALYZER:

RANGE MHz	0-110
FREQUENCY	0 MHz
BANDWIDTH	kHz
SCAN WIDTH	PER DIVISION
SCAN WIDTH PER DIVISION	20 kHz
INPUT ATTENUATION	10 dB
SCAN TIME PER DIVISION	5 SECONDS
LOG REF LEVEL	-30 dBm
LOG/LINEAR	LOG
VIDEO FILTER	100 Hz
SCAN MODE	INT
SCAN TRIGGER	AUTO
A6 APC SEARCH	NORMAL
TUNING STABILIZER	On

- Adjust FINE TUNE to set the L.O. feedthrough signal on the -3 graticule line.
- Check for a 100 kHz residual signal at the +2 graticule line.
- If the 100 kHz residual signal is > -100 dBm, then connect the test setup shown in Figure 5-14, and make the following control settings:

310A:

BANDWIDTH	1000
FREQUENCY (KC)	100
MAX INPUT VOLTAGE	03
ABSOLUTE/RELATIVE	ABSOLUTE
MODE	NORMAL
RANGE (DB)	-40

- Connect the test lead from the wave analyzer to A6C2. Monitor the amount of 100 kHz signal present.
- Tune the wave analyzer for maximum 100 kHz signal indication.
- Adjust A6A1C31, the 100 kHz rejection adjustment, for minimum signal indication on the wave analyzer. See adjustment location illustrations in Section VIII.
- Maximum signal at null should be <100 microvolts.

_____100μV

ADJUSTMENT PROCEDURES (cont'd)

5-31. APC Tuning Stabilizer Final Check

REFERENCE: Service Sheet 6.

DESCRIPTION: A signal from a comb generator is displayed on the analyzer CRT. As the stabilizer is switched on, the amount of signal shift is observed. The stabilizer is then switched off and again the amount of signal shift is observed.

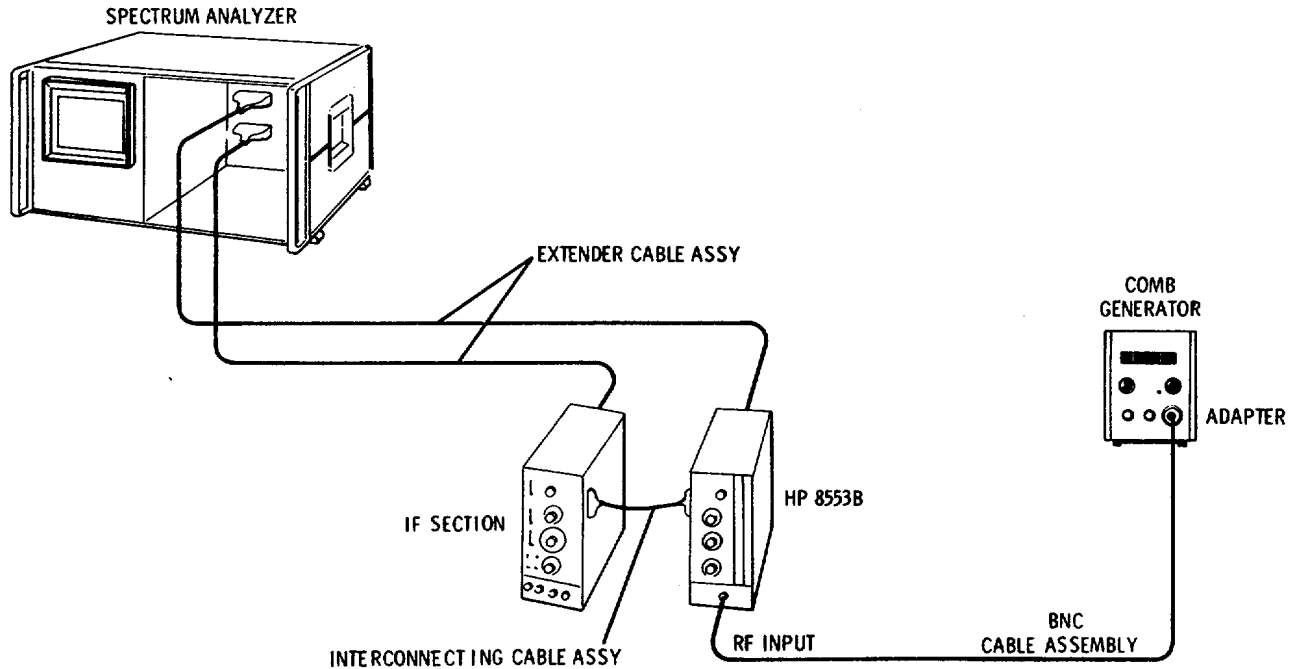

Figure 5-15. APC Tuning Stabilizer Final Check Test Setup

EQUIPMENT:

Comb Generator	HP 8406A
BNC Cable Assembly.....	HP 10503A
Extender Cable Assembly.....	HP 11592-60015
Interconnecting Cable Assembly	HP 11592-60016
BNC Female-to-Male Adapter	UG-201A/U

1. Connect the test setup in Figure 5-15 and make the following control settings:

ANALYZER:

RANGE MHz	0-110
TUNING STABILIZER.....	OFF
FREQUENCY	100 MHz
BANDWIDTH.....	1 kHz
SCAN WIDTH.....	PER DIVISION
SCAN WIDTH PER DIVISION	20 kHz

ADJUSTMENT PROCEDURES (cont'd)

5-31. APC Tuning Stabilizer Final Check (cont'd)

ANALYZER Control Settings (cont'd)

INPUT ATTENUATION..... 10 dB
 BASE LINE CLIPPERMax ccw
 SCAN TIME PER DIVISION 10 MILLISECONDS L
 LOG REF LEVEL..... +10 dBm
 LOG REF LEVEL Vernier..... 0
 VIDEO FILTER OFF
 SCAN MODE INT
 SCAN TRIGGER AUTO
 LOG/LINEAR LOG
 A6 APC SEARCH NORMAL

8406A:

COMB FREQUENCY (MC)..... 100 MC
 INTERPOLATION AMPLITUDE..... OFF
 OUTPUT AMPLITUDE..... 3 o'clock

2. Connect the comb signal to the analyzer RF INPUT.
3. Tune the FREQUENCY control to center the display. Keep FINE TUNE centered.
4. Turn SCAN WIDTH PER DIVISION to 2 kHz. Use FINE TUNE to center the display.
5. Turn TUNING STABILIZER to on. Observe the amount of signal shift. The display should shift no more than 5 divisions (10 kHz). _____ 5 Div
6. Center the display with the FINE TUNE control.
7. Turn TUNING STABILIZER to OFF, and observe the amount of signal shift. The display should shift no more than 5 divisions (10 kHz). _____ 5 Div

Table 5-4. Check and Adjustment Test Record

Hewlett-Packard Model 8553B Spectrum Analyzer RF Section			Test Performed by _____		
Serial No. ____ - _____			Date _____		
Para. No.	Test Description	Measurement Units	Min	Actual	Max
5-22	First Local Oscillator Adjustment				
	First LO upper limit: 310 ± 10 MHz	MHz	309	_____	311
	First LO				
	Dial Frequency Limit				
	5 205 ±0.3 div	divisions	-0.3	_____	+0.3
	15 215 ±0.3 div	divisions	-0.3	_____	+0.3
	25 225 ±0.3 div	divisions	-0.3	_____	+0.3
	35 235 ±0.3 div	divisions	-0.3	_____	+0.3
	45 245 ±0.3 div	divisions	-0.3	_____	+0.3
	55 255 ±0.3 div	divisions	-0.3	_____	+0.3
	65 265 ±0.3 div	divisions	-0.3	_____	+0.3
	75 275 ±0.3 div	divisions	-0.3	_____	+0.3
85 295 ±0.3 div	divisions	-0.3	_____	+0.3	
95 295 ±0.3 div	divisions	-0.3	_____	+0.3	
105 305 ±0.3 div	divisions	-0.3	_____	+0.3	
5-23	Tuning Range Adjustment				
	Comb signals align within ±1 MHz	divisions	-5	_____	+5
	Display centered at 90 MHz within ±1 MHz	divisions	-5	_____	+5
5-24	Marker accuracy ±400 kHz	divisions	-4	_____	+4
	200 MHz IF Bandpass Adjustment				
5-25	Upper passband: 50 dB down, 30 MHz above center	dB	-50	_____	
	Flatness: ±9.4 div. over 2 horizontal div.	divisions	-0.4	_____	+0.4
5-26	150 MHz Oscillator Adjustment				
	Frequency: 150 MHz ±.10 kHz	MHz	149.990	_____	150.010
	Amplitude: 150-250 mV rms	mV rms	150	_____	250
5-26	120 MHz Low Pass Filter Check and Adjustment				
	Flatness: 30-100 MHz	divisions	5.5	_____	6.5
	Roll-off: 110-125 MHz	divisions	1	_____	

Table 5-4. Check and Adjustment Test Record

Para. No.	Test Description	Measurement Units	Min	Actual	Max
5-27	100 kHz Reference Oscillator Check External -12.6 Vdc supply: Amplitude: 6 +0.4 V p-p Period is 10 +0.5 ,s between -10.5 and -14.5 Vdc Internal -12.6 Vdc supply: Amplitude Period:		V p-p	5-6	6.4
		μ s	9.5	10.5	
		V p-p	5.6	6.4	
		μ s	9.5	10.5	
5-28	APC Sampler Adjustment Balance: Adjust bias for ± 0.3 Vdc Efficiency: 2nd and 3rd samples equal amplitude	Vdc (\sqrt)	-0.3	+0.3	
5-29	APC Search Oscillator Checks A6C2 waveform amplitude: 2-2.8 V p-p A6C2 waveform period: 100 +25 ms A6C2 waveform search amplitude: 1.5 +0.2V p-p	V p-p	2	2.8	
		ms	75	125	
		V p-p	1.3	1.7	
5-30	APC 100 kHz Rejection Adjustment 100 kHz signal at null: <100 μ V	μ V		100	
5-31	APC Tuning Stabilizer Final Check Turn TUNING STABILIZER on: Turn TUNING STABILIZER off:	divisions		5	
		divisions		5	

**SECTION VI
REPLACEABLE PARTS**

6-1. This section contains information relative to ordering replacement parts and assemblies.

6-2. Table 6-1 provides correct stock numbers for use when ordering printed circuit board assemblies on an exchange basis.

6-3. Table 6-2 provides an index of reference designations and abbreviations used in the preparation of manuals by Hewlett-Packard.

6-4. Table 6-4 provides code number identification of manufacturers.

6-5. Table 6-3 provides component description, part numbers, and other required ordering information.

Table 6-1. Part Numbers for Assy Exchange Orders

8553B	Assembly	Part Number	Exchange Assy Part Number
A3	Input Attenuator	08553-6021	08553-6078
A5	Voltage Control	6007	6079
A6	APC	6010	6076
A7	VTO	6003	6072
A8	Reference Oscil.	60131	60134
A9	200 MHz IF	6004	6073
A9A2	First Converter	6002	6071
A10	Second Converter	60132	60135

Table 6-2. Reference Designators

REFERENCE DESIGNATORS							
A	= assembly	F	= fuse	P	= plug	V	= vacuum tube, neon bulb.
B	= motor	FL	= Filter	Q	= transistor		photocell, etc.
BT	= battery	J	= jack	R	= resistor	VR	= voltage regulator
C	= capacitor	K	= relay	RT	= thermistor	W	= cable
CP	= coupler	L	= inductor	S	= switch	X	= socket
CR	= diode	LS	= loud speaker	T	= transformer	Y	= crystal
DL	= delay line	M	= meter	TB	= terminal board	Z	= tuned cavity, network
DS	= device signaling (lamp)	MK	= microphone	TP	= test point		
E	= misc electronic part	MP	= mechanical part	U	= integrated circuit		
ABBREVIATIONS							
A	= amperes	H	= henries	N/O	= normally open	RMO	= rack mount only
AFC	= automatic frequency control	HDW	= hardware	NOM	= nominal	RMS	= root-mean square
AMPL	= amplifier	HEX	= hexagonal	NPO	= negative positive zero (zero temperature coef- ficient)	RWV	= reverse working voltage
BFO	= beat frequency oscilla- tor	HG	= mercury			S-B	= slow-blow
BE CU	= beryllium copper	HR	= hour(s)	NPN	= negative-positive- negative	SCR	= screw
BH	= binder head	Hz	= Hertz			SE	= selenium
BP	= bandpass	IF	= intermediate freq	NRFR	= not recommended for field re- placement	SECT	= section(s)
BRS	= brass	IMPG	= impregnated			SEMICON	= semiconductor
BWO	= backward wave oscilla- tor	INCD	= incandescent	NSR	= not separately replaceable	SI	= silicon
		INCL	= include(s)			SIL	= silver
		INS	= insulation(ed)	OBD	= order by description	SL	= slide
		INT	= internal	OH	= oval head	SPG	= spring
CCW	= counterclockwise			OX	= oxide	SPL	=special
CER	= ceramic	K	= kilo = 1000	P	= peak	SST	= Stainless steel
CMO	= cabinet mount only	LH	= left hand	PC	= printed circuit	SR	= split ring
COEF	= coefficient	LIN	= linear taper	PF	= picofarads= 10 ⁻¹² farads	STL	= steel
COM	= common	LK WASH	= lock washer	PH BRZ	= phosphor bronze	TA	= tantalum
COMP	= composition	LOG	= logarithmic taper			TD	= time delay
COMPL	= complete	LPF	= low pass filter	PHL	= Phillips	TGL	= toggle
CQNN	= connector			PIV	= peak inverse voltage	THD	= thread
CP	= cadmium plate	M	= milli 10 ⁻³	NPN	= positive-negative positive	TI	= titanium
CRT	= cathode-ray tube	MEG	= meg =106	PIO	= part of	TOL	= tolerance
Cw	= chodkwise	MET FLM	= metal film	POLY	= polystyrene	TRIM	= trimmer
DEPC	= deposited carbon	NMET OX	= metallic oxide	PORC	= porcelain	TWT	= traveling wave tube
DR	= drive	MFR	= manufacturer	POS	= position(s)		
ELECT	= electrolytic	MHz	= mega Hertz	POT	= potentiometer	μ	= micro = 10 ⁻⁶
ENCAP	= encapsulated	MINAT	= miniature	Ph	= peak-to-peak	VAR	= variable
EXT	= external	MOM	=momentary	PT	= point	VDCW	= dc working volts
F	= farads	MOS	= metalized substrate	PWV	= peak working volt- age	W/	= with
FH	= flat head	MTG	= mounting			W	= watts
FIL H	= Fillister head	MY	= "mylar"	RECT	= rectifier	WIV	= working inverse voltage
FXD	= fixed	MY	= "mylar"	RF	= radio frequency	WW	= wirewound
FxD	= fixed	N	= nano (10 ⁻⁹)	RH	= round head or right hand	W/O	= without
G	= giga (109)	N/C	= normally closed				
GE	= germanium	NE	= neon				
GL	= glass	NI PL	= nickel plate				
GRD	= ground(ed)						

TABLE 6-3. Replaceable Parts

Reference Designation	HP Part Number	Qty	Description	Mfr Code	Mfr Part Number
A1	08553-60126	1	SWITCH ASSY: BANDWIDTH	28480	08553-60126
A1	08553-00109	1	DIAL-KNOB ASS (BANDWIDTH)	28480	08593-00109
A1CR1	1901-0025	9	DIODE: SILICON 100MA/IV	01263	FD 2387
A1CR2	1901-0025		DIODE: SILICON 100MA/IV	07263	FD 2367
A1CR3	1901-0025		DIODE: SILICON 100MA/IV	01263	FD 2367
A1CR4	1901-0025		DIODE: SILICON 100MA/IV	07263	FD 2307
A1R1	0157-0444	4	R:FXD MET FLM 12.1K OHM 1% 1/8W	29480	0751-0444
A1R2	0698-3157	2	R:FXD MET FLM 19.6K OHM 1% 1/8W	28480	0698-3157
A1R3	0698-4534	4	R:FXD MET FLM 309K OHM 1% 1/8W	20460	0698-4534
A1R4	0698-4521	4	R:FXD MET FLM 154K OHM 1% 1/8W	28480	0698-4521
A1R5	0698-4521		R:FXD MET FLM 15' OHM 1% 1/8W	28480	0698-4521
A1R6	0698-4534		R:FXD MET FLM 309K OHM 1% 1/8W	20480	0698-4534
A1R7	0698-4521		R:FXD MET FLM 154K OHM 1% 1/8W	28480	0698-4521
A1R8	0698-4534		R:FXD MET FLM 309K OHM 1% 1/8W	28460	0698-4534
A1R9	0698-4521		R:FXD MET FLM 154 OHM 1% 1/8W	28480	0698-4521
A1R10	0698-4534		R:FXD MET FLM 309K OHM 1% 1/8W	28480	0698-534
A1R11	0757-0460	1	R:FXD MET FLM 61.9K OHM 1% 1/8W	28460	0757-0460
A1R12	0698-4491	1	R:FXD MET FLM 30.9K OHM 1% 1/8W	28480	0698-4491
A1R13			NOT ASSIGNED		
A1R14	0751-0453	1	R:FXD MET FLM 30.1K OHM 1% 1/8W	28480	07157-0453
A1S1	3100-2658	1	SWITCH ROTARY 10 POSITIONS	28480	3100-2658
A2	08553-60125	1	SWITCH ASSY:SCAN WIDTH	28480	08553-60125
A2	08553-00111	1	DIAL KNOB ASSY SCAN WIDTH	28480	09553-00111
A2	0310-0102	1	KNOB:RED BAR	26460	03170-0102
A2CR1	1901-0450	6	DIODE: SILICON	28480	1901-0450
A2CR2	1901-0450		DIODE: SILICON	28480	1901-0450
A2CR3	1901-0040	25	DIODE: SILICON 30MA 30MV	07263	FDG1088
A2MP1	1200-0063	5	LUG:CRIMP	28480	1200-0063
A2MP2	5020-0176	5	INSULATOR FOR SNAP-ON PINS	28480	5020-0176
A2R1	0698-3260	9	R:FXD MET FLM 464K OHM 1% 1/8W	28480	0690-3260
A2R2	0698-3260		R:FXD MET FLM 464K OHM 1% 1/8W	28480	0698-3260
A2R3	0698-3260		R:FXD MET FLM 464K OHM 1% 1/8W	28480	0698-3260
A2R4	0698-3260		R:FXD MET FLM 464K OHM 1% 1/8W	29480	0698-3260
A2R5	0698-3260		R:FXD MET FLM 464K OHM 1% 1/8W	28480	06983260
A2R6	0698-3271	6	R:FXD MET FLM 115K OHM 1% 1/8W	28480	0698-3271
A2R7	0698-3260		R:FXD MET FLM 464K OHM 1% 1/8W	28480	0698-3260
A2R8	0698-3271		R:FXD MET FLM 115K OHM 1% 1/8W	28480	0698-3271
A2R9	0757-0488	4	R:FXD MET FLM 909K OHM 1% 1/8W	28480	0757-0488
A2R10	0757-0488		R:FXD MET FLM 909K OHM 1% 1/8W	28480	0757-0488
A2R11	0757-0488		R:FXD MET FLM 909K OHM 1% 1/8W	28480	0757-0488
A2R12	0757-0488		R:FXD MET FLM 909K OHM 1% 1/8W	28480	0751-0488
A2R13	0698-3211		R:FXD MET FLM 115K OHM 1% 1/8W	28480	0698-3211
A2R14	0698-3271		R:FXD MET FLM 115K OHM 1% 1/8W	28460	0696-3271
A2R15	0698-3449	4	R:FXD MET FLM 28.71K OHM 1% 1/8W	28480	0698-3449
A2R16	0698-3159	1	R:FXD MET FLM 26.1K OHM 1% 1/8W	28480	0698-3159
A2R17	0698-3271		R:FXD MET FLM 115K OHM 1% 1/8W	28480	0698-3211
A2R18	0698-3271		R:FXD MET FLM 115K OHM 1% 1/8W	28460	0698-3211
A2R19	0698-7888	1	R:FXD MET FLM 22.2 OHM 0.25 % 1/8W	28480	0690-7888
A2R20	0696-6296	2	R:FXD MET FLM 20.00 OHM 0.25% 1/8W	26460	0698-6296
A2R21	0698-7533	1	R:FXD MET FLM 30 OHM 0.25% 1/8W	28480	0698-7533
A2R22	0698-4190	2	R:FXD MET FLM 50 OHM 0.25% 1/8W	28460	0698-4190
A2R23	0698-1532	1	R:FXD MET FLM 100 OHM 0.25 % 1/8W	28468	0698-7532
A2R24	0698-6296		R:FXD MET FLM 20.00 OHM 0.25% 1/8W	28480	0698-6296
A2R25	0698-6314	1	R:FXD MET FLM 10 OHM 0.25% 1/8W	28480	0698-6314
A2R26	0698-4190		R:FXD MET FLM 50 OHM 0.25% 1/8W	28480	0698-4190
A2R27	0698-6299	2	R:FXD MET FLM 100.40 OHM 0.25% 1/8W	28480	0698-6299
A2R28	0698-6300	1	R:FXD MET FLM 200.90 OHM 0.25% 1/8W	28480	0698-6300
A2R29	06986299		R:FXD MET FLM 100.40 OHM 0.25% 1/8W	28480	0698-6299
A2R30	0698-6315	1	R:FXD MET FLM 503.1 OHM 0.25 % 1/8W	28480	0698-6315
A2R31	0698-6302	1	R:FXD MET FLM 995 OHM 0.25% 1/8W	28480	0698-6302
ANS1	3100-2657	1	SWITCH:ROTARY 18 POSITIONS	28480	3100-2657
A3	08553-6021	1	SWITCH ASSY:INPUT ATTENUATOR	28480	08553-6021
A3	08553-0014	1	DIAL KNOB ASSY	28480	08553-0014
A3J1	125-0836	2	CONNECTOR:RF,SUB-MINIATURE	98291	50-053-0000
A3J2	1250-0836		CONNECTDR:RF,SUB-MINIATURE	98291	50-053-0000
A3MP1	08553-0015	1	COVER:INPUT ATTEN SWITCH	28480	08553-0015
A3MP2	08553-0018	1	CLAMP:SWITCH COVER	26480	065531-008
A3R1	0698-6668	2	R:FXD MET FLM 53.3 OHM 0.25% 1/8W	28480	0698-6668
A3R2	0698-6669	1	R:FXD MET FLM 790 OHM 0.25% 1/8W	28480	0698-669
A3R3	0698-6668		R:FXD MET FLM 53.3 OHM 0.25% 1/8W	28480	06986668
A3R4	069a-5192	2	R:FXD MET FLM 61.11 OHM 0.25% 1/8W	28480	069B-5192
A3R5	0698-5401	1	R:FXD MET FLM 247.50 OHM 0.25% 1/8W	28480	0698-5401
A3R6	0698-5192		R:FXD MET FLM 61.11 OHM 0.25% 1/8W	28480	0698-5192
A3R7	0698-5196	2	R:FXD MET FLM 96.25 OHM 0.25% 1/8W	28460	0698-5196
A3R8	0698-5194	1	R:FXD MET FLM 71.15 OHM 0.25% 1/8W	28480	0698-5194

See introduction to this section for ordering information

TABLE 6-3. Replaceable Parts

Reference Designation	HP Part Number	Qty	Description	Mfr Code	Mfr Part Number
A3R9	0698-5196		R:FXD MET FLM 96.25 OHM 0.253 I/S8	28480	0698-5196
A3R10	0698-3400	1	R:FXD MET FLM 147 OHM It 1/2	28480	0698-3400
A3S1	08553-4003	1	EXTENSION:SHAFT	28480	08553-4003
A3S1	3130-0193	1	SECTION:ROTARY SNITCH	28480	3130-0193
A3S1	3130-0195	2	SECTION:ROTARY SWITCH	28480	3130-0195
A3S1	3130-0195		SECTION:ROTARY SWITCH	28480	3130-0195
A3S1	3130-0196	2	SECTION:ROTARY SWITCH	28480	3130-0196
A3S1	3130-0196		SECTION:ROTARY SWITCH	28480	3130-0196
A4	08553-6008	1	BOARD ASSY:PRESET SCAN	28480	08553-6008
A4C1	0140-0198	3	C:FXD MICA 200 PF 53	72136	RDM15F201J3C
A4CR1	1910-0016	5	DIODE:GERMINIUM 100 MA/0.85V 60PIV	93332	02361
A4CR2	1901-0450		DIODE: SILICON	28480	1901-0450
A4CR3	1901-0450		DIODE: SILICON	28480	1901-0450
A4CR4	1901-0450		DIODE: SILICON	28480	1901-0450
A4CR5	1901-0450		DIODE: SILICON	28480	1901-0450
A4Q1	1854-0071	11	TSTR:S1 NPN(SELECTED FROM 2N3704)	284P0	1854-0071
A4Q2	1854-0071		TSTR:S1 NPN(SELECTED FROM 2N3704)	28480	1854-0071
A4Q3	1853-0020	10	TSTR:S1 NPN(SELECTED FROM 2N3702)	28480	1853-0020
A4Q4	1854-0071		TSTR:S1 NPN(SELECTED FROM 2N3704)	28480	1854-0071
A4Q5	1854-0071		TSTR:S1 NPN(SELECTED FROM 2N3704)	28480	1854-0071
A4Q6	1854-0071		TSTR:S1 NPN(SELECTED FROM 2N3704)	28480	1854-0071
A4Q7	1854-0071		TSTR:S1 NPN(SELECTED FROM 2N37041)	28480	1854-0071
A4Q8	1853-0020		TSTR:S1 NPN(SELECTED FROM 2N3702)	28480	1853-0020
A4R1	0757-0438	2	R:FXD MET FLM 5.11K OHM I 1/8W	28480	0757-0438
A4R2	0698-4483	1	R:FXD MET FLM 18.7K OHM I 11.8	28480	0698-4483
A4R3	0757-0438		R:FXD MET FLM 5.11K OHM 13 1181	28480	0757-0438
A4R4	0698-3260		R:FXD MET FLM 464K OHM 13 1/8W	28480	0698-3260
A4R5	0757-0439	1	R:FXD MET FLM 6.81K OHM 13 18/W	28480	0757-0439
A4R6	0757-0442	5	R:FXD MET FLM 10 % OHM I /SW	28480	0757-0442
A4R7	2100-1150	3	R:VAR WW 1K OHM 51 TYPE V 11	28480	2100-1758
A4R8	0698-3160	6	R:FXD MET FLM 31.6K OHM 1% 1/8W	28480	0698-3160
A4R9	0698-3160		R:FXD MET FLM 31.6K OHM 1% 1/8W	28480	0698-3160
A4R10	0698-3460	1	R:FXD MET FLM 422K OHM 1% 1/8W	28480	0698-3460
A4R11	0757-0123	3	R:FXD MET FLM 34.8K OHM 1% 1/8W	28480	0757-0123
A4R12	0698-3243	1	R:FXO MET FLM 178 KIT OHM 1% 1/8W	28480	0698-3243
A4R13	0698-3161	4	R:FXD MET FLM 38.3K OHM 1% 1/8W	28480	0698-3161
A4			MISCELLANEOUS		
A4	0360-0124	8	TERMINAL:SOLDER LUG	28480	0360-0124
A4	0380-0863	1	STANDOFF 1/8" LG	06540	9531-125-80440-0
A5	00553-6007	1	CONTROL A5SY:VOLTAGE	28480	08553-6007
A5MP1	08553-2031	1	COVER:VOLTAGE CONTROL BOARD	28480	08553-2031
A5A1	085s36057	1	BOARD A5SY:VOLTAGE CONTROL	28480	08553-6057
A5A1C1	0180-0116	9	C:FXD ELECT 6.8 UF 103 35VDCW	56289	1500685X903582-DYS
A5A1C2	0160-0163	1	C:FXD MY 0.033 UF 10% 200VDCW	56289	192P33392-PTS
A5A1C3	0180-0116		C:FXD ELECT 6.8 UF 10% 35VDCW	56289	150D685X903582-DYS
A5A1C4	0180-0269	1	C:FXD ELECT 1.0 UF +50-10% 150VDCW	56289	30D105F1508A2-DSM
A5A1C5	0160-2143	1	C:FXD CER 2000 PF +80-20% 1000VDCW	91418	TYPE 8
A5A1C6	0180-0097	2	C:FXD TANT. 47 UF 103 35VDC1	56289	1500476X9035S2-DYS
A5A1C7	0160-0161	1	C:FXD MY 0.01 UF 10% 200VDCW	56289	192P10392-PTS
A5A1CS	0160-2145	1	C:FXD CER 5000 PF +80-20% 100VDCW	91418	TA
A5A1C9	0160-2199	1	C:FXD MICA 30 PF 5% 300VDCW	28480	0160-2199
A5A1C10	0160-2930	4	C:FXD CER 0.01 UF +80-20% 100VDCW	91418	TA
A5A1C11	0160-0157	1	C:FXD MY 0.0047 UF 10% 200VDCW	56289	192P47292-PTS
A5A1C12	0180-0098	1	C:FXD ELECT 100 UF 20% 20VDCW	56289	1500107X002052-DYS
A5A1CR1	1902-0033	1	DIODE:BREAKDOWN 6.2V	04713	1N823
A5A1CR2	1902-0785	1	DIODE:BREAKDOWN 9.09V 5%	04713	1N936
A5A1CR3	1902-3036	1	DIODE:BREAKDOWN 3.16V 5%	04713	S210939-38
A5A1CR4	1901-0040		DIODE:SILICON 30MA 30VV	07263	FDG10SS
A5A1CR5	1902-3104	3	DIODE:BREAKDOWN 5.62V 5%	04713	SZ10939-110
A5A1CR6	1901-0040		DIODE:SILICON 30MA 30VV	07263	FDG1088
A5A1CR7	1901-0040		DIODE:SILICON 30MA 30VV	07263	FDG001088
A5A1CR8	1901-0040		DIODE:SILICON 30MA 30VV	07263	F001088
A5A1CR9	1902-3345	1	DIODE:SILICON 51.1V	28480	1902-3345
A5A1CR10	1901-0040		DIODE:SILICON 30MA 30VV	07263	FDG1088
A5A1CR11	1901-0040		DIODE:SILICON 30MA 30VV	07263	FDG1088
A5A1CR12	1901-0040		DIODE:SILICON 30MA 30VV	07263	FDG1088
A5A1CR13	1901-0040		DIODE:SILICON 30MA 30VV	07263	FDG1088
A5A1CR14	1901-0040		DIODE:SILICON 30MA 30VV	07263	FDG1088
A5A1CR15	1901-0040		DIODE:SILICON 30MA 30VV	07263	FDG1088
A5A1CR16	1901-0040		DIODE:SILICON 30MA 30VV	07263	FDG1088
A5A1CR17	1901-0040		DIODE:SILICON 30MA 30VV	07263	FDG1088
A5A1CR18	1901-0040		DIODE:SILICON 30MA 30VV	07263	FDG1088
A5A1CA19	1901-0040		DIODE:SILICON 30MA 30VV	07263	FDG1088
A5A1CR20	1901-0040		DIODE:SILICON 30MA 30VV	07263	FDG1088

See introduction to this section for ordering information

Table 6-3. Replaceable Parts

Reference Designation	HP Part Number	Qty	Description	Mfr Code	Mfr Part Number
A5A1CR21	1901-0039	1	DIODE:SILICON 200MA 50WV	28480	1901-0039
A5A1CR22	1901-0040		DIODE:SILICON 30MA 30WV	07263	FDG1088
A5A1CR23	1901-0040		DIODE:SILICON 30MA 30WV	07263	FDG1088
A5A1L1	9140-0129	8	COIL:FXD RF 220 UH	28480	9140-0129
A5A1L2	9140-0129		COIL:FXD RF 220 UM	28480	9140-0129
A5A1Q1	1854-0071		TSTR:S1 NPN (SELECTED FROM 2N3704)	28480	1854-0071
A5A1Q2	1854-0022	2	TSTR:S1 NPN	07263	S17843
A5A1Q3	1853-0020		TSTR:S1 NPN (SELECTED FROM 2N3702)	28480	1853-0020
A5A1Q4	1854-0221	2	TSTR:S1 NPN(REPL. BY 2N4044)	28480	185-0221
A5A1Q5	1854-0022		TSTR:S1 NPN	07263	S17843
A5A1Q6	1853-0020		TSTR:S1 NPN (SELECTED FROM 2N3702)	28480	1853-0020
A5A1Q7	1854-0221		TSTR:S1 NPN (REPL. BY 2N4044)	28480	1854-0221
A5A1R1	0757-0199	4	R:FXD MET FLM 21.5K OHM 1% 1/8W	28480	0757-0199
A5A1R2	0757-0465	1	R:FXD MET FLM 100K OHM 1% 1/8W	28480	0757-0465
A5A1R3	0757-0416	8	R:FXD MET FLM 511 OHM 1% 1/8W	28480	0757-0416
A5A1R4	0757-0442		R:FXD MET FLM 10.0K OHM 1% 1/8W	28480	0757-0442
A5A1R5	0698-3260		R:FXD MET FLM 464K OHM 1% 1/8N	28480	0698-3260
A5A1R6	0683-9145	2	R:FXD COMP 910K OHM 5% 1/4W	01121	CB 9145
A5A1R7	0698-3152	4	R:FXD MET FLM 3.48K OHM 1% 1/8W	28480	0698-3152
A5A1R8	0757-0280	12	R:FXD MET FLM 1K OHM 1% 1/8W	28480	0757-0280
A5A1R9	0698-3151	1	R:FXD MET FLM 2.87K OHM 1% 1/8W	28480	0698-3151
A5A1R10	0757-0280		R:FXD MET FLM 1K OHM 1% 1/8W	28480	0757-0280
A5A1R11	0698-3153	1	R:FXD MET FLM 3.83K OHM 1% 1/8W	28480	0698-3153
A5A1R12	0757-0424	2	R:FXD MET FLM 1.10K OHM 1% 1/8W	28480	0757-0424
A5A1R13	2100-1657	1	R:VAR WW .1K OHM 10% 1/8W	28480	2100-1657
A5A1R14	0764-0044	2	R:FXD MET OX 8.2K OHM 5% 2W	28480	0764-0044
A5A1R15	0757-0280		R:FXD MET FLM 1K OHM 1% 1/8W	28480	0757-0280
A5A1R16	0757-0346	4	R:FXD MET FLM 10 OHM 1% 1/8W	28480	0757-0346
A5A1R17	0698-3439	1	R:FXD MET FLM 178 OHM 1% 1/8W	28480	0698-3429
A5A1R18	0757-0442		R:FXD MET FLM 10.0K OHM 1% 1/8W	28480	0757-0442
A5A1R19	0698-3260		R:FXD MET FLM 464K OHM 1% 1/8W	28480	0698-3260
A5A1R20	0683-8245	2	R:FXD COMP 820K OHM 5% 1/4W	01121	CB 8245
A5A1R21	0698-3152		R:FXD MET FLM 3.48K OHM 1% 1/8W	28480	0698-3152
A5A1R22	0757-0416		R:FXD MET FLM 511 OHM 1% 1/8W	28480	0757-0416
A5A1R23	0757-0839	1	R:FXD MET FLM 10K OHM 1% 1/2W	28480	0757-0839
A5A1R24	0698-3154	6	R:FXD MET FLM 4.22K OHM 1% 1/8W	28480	0698-3154
A5A1R25	0698-3157		R:FXD MET FLM 19.6K OHM 1% 1/8W	28480	0698-3157
A5A1R26	0764-0044		R:FXD MET OX 8.2K OHM 5% 1/2W	28480	0764-0044
A5A1R27	0757-0815	1	R:FXD MET FLM 562 OHM 1% 1/2W	28480	0757-0815
A5A1R28	0698-3435	1	R:FXD MET FLM 38.3 OHM 1% 1/8W	28480	0698-3435
A5A1R29	0757-0424		R:FXD MET FLM 1.10K OHM 1% 1/8W	28480	0757-0424
A5A1R30	0698-0084	5	R:FXD MET FLM 2.15K OHM 1% 1/8W	28480	0698-0084
A5A1R31	0757-0278	4	R:FXD MET FLM 1.78K OHM 1% 1/8W	28480	0757-0278
A5A1R32	2100-0942	4	R:VAR FLM 50K OHM 20% 3/4W	28480	2100-0942
A5A1R32			FACTORY SELECTED PART		
A5A1R33	0698-3160		R:FXD MET FLM 31.6K OHM 1% 1/8W	28480	0698-3160
A5A1R33			FACTORY SELECTED PART		
A5A1R34	0757-0467	2	R:FXD MET FLM 121K OHM 1% 1/8W	28480	0757-0467
A5A1R34			FACTORY SELECTED PART		
A5A1R35	0757-0403	1	R:FXD MET FLM 121 OHM 1% 1/8W	28480	0757-0403
A5A1R36	0757-0816	1	R:FXD MET FLM 681 OHM 1% 1/2W	28480	0757-0816
A5A1R37	0757-0398	4	R:FXD MET FLM 75 OHM 1% 1/8W	28480	0757-0398
A5A1R38	2100-1910	1	R:VAR 100K OHM 20% 3/4W	28480	2100-1910
A5A1R38			FACTORY SELECTED PART		
A5A5R39	0698-3160		R:FXD MET FLM 31.6K OHM 1% 1/8W	28480	0698-3160
A5A1R39			FACTORY SELECTED PART		
A5A1R40	0698-3438	9	R:FXD MET FLM 147 OHM 1% 1/8W	28480	0698-3438
A5A1R41	2100-0942		R:VAR FLM 50K OHM 20% 3/4W	28480	2100-0942
A5A1R41			FACTORY SELECTED PART		
A5A1R42	0698-3158	1	R:FXD MET FLM 23.7K OHM 1% 1/8W	28480	0698-3158
A5A1R42			FACTORY SELECTED PART		
A5A1R43	0698-3438		R:FXD MET FLM 147 OHM 1% 1/8W	28480	0698-3438
A5A1R44	2100-0942		R:VAR FLM 50K OHM 20% 3/4W	28480	2100-0942
A5A1R44			FACTORY SELECTED PART		
A5A1R45	0757-0199		R:FXD MET FLM 21.5K OHM 1% 1/8W	28480	0757-0199
A5A1R45			FACTORY SELECTED PART		
A5A1P46	0698-3438		R:FXD MET FLM 147 OHM 1% 1/8W	28480	0698-3438
A5A1R47	2100-0942		R:VAR FLM 50K OHM 20% 3/4W	28480	2100-0942
A5A1R47			FACTORY SELECTED PART		
A5A1R48	0698-3136	4	R:FXD MET FLM 17.8K OHM 1% 1/8W	28480	0698-3136
A5A1R48			FACTORY SELECTED PART		
A5A1R49	0690-3438		R:FXD MET FLM 147 OHM 1% 1/8W	28480	0698-3438
A5A1R50	2100-1762	3	R:VAR NW 20K 5% 1/8W	75042	CT-106-4
A5A1R51	0698-3136		R:FXD MET FLM 17.8K OHM 1% 1/8W	28480	0698-3136
A5A1R51			FACTORY SELECTED PART		

See introduction to this section for ordering information

Table 6-3. Replaceable Parts

Reference Designation	HP Part Number	Qty	Description	Mfr Code	Mfr Part Number
A5A1R52	0698-3438		R:FXD MET FLM 147 OHM 1% 1/8W	28480	0698-3438
A5A1R53	2100-1762		R:VAR WW 20K 5% 1W	75042	CT-106-4
A5A1R54	0698-3156	1	R:FXD MET FLM 14.7K OHM 1% 1/8W FACTORY SELECTED PART	28480	0698-3156
A5A1R54					
A5A1R55	0698-3438		R:FXD MET FLM 147 OHM 1% 1/8W	28480	0698-3438
A5A1R56	2100-1762		R:VAR WW 20K 5% 1W FACTORY SELECTED PART	75042	CT-106-4
A5A1R56					
A5A1R55	0757-0289	2	R:FXD MET FLM 13.3K OHM 1% 1/8W FACTORY SELECTED PART	28480	0757-0289
A5A1R57					
A5A1R58	0698-3438		R:FXD MET FLM 147 OHM 1% 1/8W	28480	0698-3438
A5A1R59	2100-1761	3	R:VAR WW 10K OHM 5% TYPE V 1W	28480	2100-1761
A5A1R60	0757-0289		R:FXD MET FLM 13.3K OHM 1% 1/8W FACTORY SELECTED PART	28480	0757-0289
A5A1R60					
A5A1R61	0698-3438		R:FXD MET FLM 147 OHM 1% 1/8W	28480	0698-3438
A5A1R62	2100-1761		R:VAR WW 10K OHM 5% TYPE V 1	28480	2100-1761
A5A1R63	0157-0444		R:FXD MET FLM 12.1K OHM 1% 1/8W FACTORY SELECTED PART	28480	0757-0444
A5A1R63					
A5A1R64	0698-3438		R:FXD MET FLM 147 OHM 1% 1/8W	28480	0698-3438
A5A1R65	2100-1761		R:VAR NW 10K OHM 5% TYPE V 1	28480	2100-1761
A5A1R66	0757-0442		R:FXD MET FLM 10.0K OHM 1% 1/8W FACTORY SELECTED PART	28480	0757-0442
A5A1R66					
A5A1R67	0757-0398		R:FXD MET FLM 75 OHM 1% 1/8W	28480	0757-0398
A5A1XA5	1251-0135	1	CONNECTOR: BODY 15 PIN MISCELLANEOUS	28480	1251-0135
A5A1					
A5A1	0360-0124		TERMINAL: SOLDER LUG	28480	0360-0124
A6	08553-6010	1	APC ASSY	28480	08553-6010
A6C1	0160-3075	3	C: FXD CER FEED-THRU 100PF 20% 500VDCW	28480	0160-3075
A6C2	0160-3075		C: FXD CER FEED-THRU 100PF 20% 500VDCW	28480	0160-3075
A6C3	0160-3005	10	C: FXD FEED-THRU 5000 PF +80-203	28480	0160-3005
A6C4	0160-3005		C: FXD FEED-THRU 5000 PF +80-203	28480	0160-3005
A6J1	1250-0830	12	CONNECTOR: RF	98291	50-047-0000
A6J2	1250-0830		CONNECTOR: RF	98291	50-047-0000
A6MP1	08553-2014	1	COVER: APC	28480	08553-2014
A6S1	3101-1338	1	SWITCH: SLIDE DPDT 0.5A 125V AC/DC	79727	GF126-0017
A6A1	08553-6060	1	BOARD ASSY: APC	28480	08553-6060
A6A1C1-					
A6A1C4			NOT ASSIGNED		
A6A1C5	0180-0116		C: FXD ELECT 6.8 UF 10% 35VDCW	56289	150D685X903582-DYS
A6A1C6	0180-0116		C: FXD ELECT 6.8 UF 10% 35VDCW	56289	150D685X903582-DYS
A6A1C7	0150-0073	4	C: FXD CER 100 PF 10% 1000VDCW	56289	C0288102E1OIKS27-CDH
A61AC8	0180-1743	1	C: FXD ELECT 0.1 UF 10% 35VDCV	56289	150D104X9035A2-DYS
A6A1C9	0180-0291	1	C: FXD ELECT 1.0 UF 10% 35VDCW	56289	1500105X9035A2-DYS
A6A1C10	0160-2205	1	C: FXD MICA 120 PF 5%	28480	0160-2205
A6A1C11	0180-0197	6	C: FXD ELECT 2.2 UF 10% 20VDCW	56289	150D225X9020A2-DYS
A6A1C12	0160-2222	2	C: FXD MICA 1500 PF 5% 300VDCW	28480	0160-2222
A6A1C13	0160-2222		C: FXD MICA 1500 PF 5% 300VDCW	28480	0160-2222
A6A1C14	0140-0198		C: FXD MICA 200 PF 5%	72136	RDMISF201J3C
A6A1C15	0140-0198		C: FXD MICA 200 PF 5%	72136	RDM15F201J3C
A6A1C16	0121-0048	4	C: VAR GL 0.8-8.5 PF 750VDCW	73899	VC9GW
A6A1C17	0160-2261	3	C: FXD CER 15 PF 5% 500VDCW	72982	301-NPO-15 PF
A6A1C18	0160-2204	1	C: FXD MICA 100PF 5%	72136	RDM15F101J3C
A6A1C19	0150-0121	2	C: FXD CER 0.1 UF +80-20% 50VDCW	56289	5C5081S-CML
A6A1C20	0180-0197		C: FXD ELECT 2.2 UF 10% 20VDCW	56289	1500225X9020A2-DYS
A6A1C21	0160-2266	7	C: FXD CER 24 PF 5% 500VDCW	72982	301-000-COGO-240J
A6A1C22	0180-0197		C: FXD ELECT 2.2 UF 10% 20VDCW	56289	1500225X9020A2-DYS
A6A1C23	4160-2227	2	C: FXD MICA 2400 PF 5%	28480	0160-2227
A6A1C24	0160-2227		C: FXD MICA 2400 PF 5%	28480	0160-2227
A6A1C25	0160-2201	1	C: FXD MICA 51 PF 5%	72136	ROM15E510J1C
A6A1C26	0170-0042	2	C: FXD MY 0.33UF 5% 100VDCW	99515	E1-3340 TYPE E120
A6A1C27	0170-0042		C: FXD MY 0.33UF 5% 100VDCW	99515	E1-3340 TYPE E120
A6A1C28	0180-0097		C: FXD TANT. 47 UF 10% 35VDCW	56289	150D476X9035S2-DYS
A6A1C29	0160-0303	1	C: FXD MYLAR .15 UF 10% 200VDCW	28480	0160-0303
A6A1C30	0160-2215	1	C: FXD MICA 750 PF 5%	28480	0160-2215
A6A1C31	0131-0004	1	C: VAR MICA 16-150 PF 175VDCW	72136	TS51410-3
A6A1CR1	1901-0049	4	DIODE: SILICON 50PIV	28480	1901-0049
A6A1CR2	1901-0049		DIODE: SILICON 50PIV	28480	1901-0049
A6A1CR3	1901-0040		DIODE: SILICON 30MA 30MV	07263	FDG1088
A6A1CR4	1901-0025		DIODE: SILICON 100MA/IV	07263	FD 2387
A6A1CR5	1901-0025		DIODE: SILICON 100MA/IV	07263	FD 2387
A6A1CR6	1901-0047	2	DIODE JUNCTION: SILICON 20PIV	28480	1901-0047
A6A1CR7	1901-0047		DIODE JUNCTION: SILICON 20PIV	28480	1901-0047
A6A1CR8	1901-0441	1	DIODE: STEP RECOVERY SILICON 90-160NS	28480	1901-0441
A6A1CR9	5082-2800	2	DIODE: SILICON	28480	5082-2800
A6A1CR10	5082-2800		DIODE: SILICON	28480	5082-2800

See introduction to this section for ordering information

Table 6-3. Replaceable Parts

Reference Designation	HP Part Number	Qty	Description	Mfr Code	Mfr Part Number
A6A1CR11	08553-8001	1	DIODE: MATCHED PAIR	28480	08553-8001
A6A1CR12			PART OF A6A1CR11		
A6A1CR13	1902-0057	1	DIODE BREAKDOWN 6.49V	28480	1902-0057
A6A1CR14	1902-3049	2	DIODE: SILICON 3.48V 2 400MW	04713	5210939-51
A6A1CR15	1902-3049		DIODE: SILICON 3.48V 23 400MW	04713	5210939-51
A6A1CR16	1910-0016		DIODE: GERMANIUM 100MA0.85V 60PIV	93332	D2361
A6A1CR17	1901-0025		DIODE: SILICON 100MA/IV	07263	FD 2387
A6A1CR18	1901-0025		DIODE: SILICON 100MA/IV	07263	FD 2387
A6A1L1	9140-0129		COIL: FXD RF 220 UH	28480	9140-0129
A6A1L2	9140-0114	2	COIL: FXD RF 10 UH	28480	9140-0114
A6A1L3	9140-0129		COIL: FXD RF 220 UH	28480	9140-0129
A6A1L4	9140-0114		COIL: FXD RF 10 UH	28480	9140-0114
A6A1L5	9100-1618	1	COIL: MOLDED CHOKE 5.60 UH	28480	9100-1618
A6A1L6	9100-1611	4	COIL: FXD 0.22 UH 203	28480	9100-1611
A6A1L7	9100-1656	1	COIL: CHOKE 1300 UH 5%	28480	9100-1656
A6A1L8	9100-1665	1	COIL: CHOKE 3300 UH 5%	28480	9100-1665
A6A1 MP1 & MP2	08553-00118	2	LUG	28480	08553-00118
A6A1Q1	1853-0020		TSTR: S1 NPN (SELECTED FROM 2N3702)	28480	1853-0020
A6A1Q2	1854-0071		TSTR: S1 NPN (SELECTED FROM 2N3704)	28480	1854-0071
A6A1Q3	1854-0071		TSTR: S1 NPN (SELECTED FROM 2N3704)	28480	1854-0071
A6A1Q4	1853-0020		TSTR: S1 PNP (SELECTED FROM 2N3702)	28480	1853-0020
A6A1Q5	1853-0020		TSTR: S1 NPN (SELECTED FROM 2N3702)	28480	1853-0020
A6A1Q6	1855-0049	1	TSTR: S1 FET N-CHANNEL DUAL	28480	1855-0049
	0340-0420	1	MOUNTING PAD: INSULATING 6 LEADS	13103	7717-80DAP
A6A1Q7	1854-0035	1	TSTR: S1 NPN	28480	1854-0035
A6A1Q8	1853-0034	3	TSTR: S1 NPN (SELECTED FROM 2N3251)	28480	1853-0034
A6A1R1	0698-3443	1	R: FXD MET FLM 287 OHM 1% 1/8W	28480	0698-3443
A6A1R2	0698-3442	4	R: FXD MET FLM 237 OHM 1% 1/8W	28480	0698-3442
A6A1R3	0757-0401	2	R: FXD MET FLM 100 OHM 1% 1/8W	28480	0757-0401
A6A1R4	0698-3444	2	R: FXD MET FLM 316 OHM 1% 1/8W	28480	0698-3444
A6A1R5	0757-0802	2	R: FXD MET FLM 162 OHM 1% 1/2W	28480	0757-0802
A6A1R6	0757-0400	2	R: FXD MET FLM 90.9 OHM 1% 1/8W	28480	0757-0400
A6A1R6			FACTORY SELECTED PART		
A6A1R7	0757-0401		R: FXD MET FLM 100 OHM 1% 1/8W	28480	0757-0401
A6A1R8	0757-0400		R: FXD MET FLM 90.9 OHM 1% 1/8W	28480	0757-0400
A6A1R8			FACTORY SELECTED PART		
A6A1R9	0757-0394	2	R:FXD MET FLM 51.1 OHM 1% 1/8W	28480	0157-0394
A6A1R10	0757-0280		R:FXD MET FLM 1K OHM 1% 1/8W	28480	0757-0280
A6A1R11	0757-0280		R:FXD MET FLM 1K OHM 1% 1/8W	28480	0757-0280
A6A1R12	0757-0123		R:FXD MET FLM 34.8K OHM 1% 1/8W	28480	0757-0123
A6A1R13	2100-1758		R:VAR NW 1K OHM 5% TYPE V 1W	28480	2100-1758
A6A1R14	0698-3160		R:FXD MET FLM 31.6K OHM 1% 1/8W	28480	0698-3160
A6A1R15	0698-0024	1	R:FXD MET FLM 2.61K OHM 1% 1/2W	28480	0698-0024
A6A1R16	0757-0279	4	R:FXD MET FLM 3.16K OHM 1% 1/8W	28480	0757-0279
A6A1R17	0757-0416		R:FXD MET FLM 511 OHM 1% 1/8W	28480	0757-0416
A6A1R18	0757-0416		R:FXD MET FLM 511 OHM 1% 1/8W	28480	0757-0416
A6A1R19	0757-0444		R:FXD MET FLM 12.1K OHM 1% 1/8W	28480	0757-0444
A6A1R20	0757-0422	1	R:FXD MET FLM 909 OHM 1% 1/8W	28480	0757-0422
A6A1R21	0757-0279		R:FXD MET FLM 3.16K OHM 1% 1/8W	28480	0757-0279
A6A1R22	0698-3136		R:FXD MET FLM 17.8K OHM 1% 1/8W	28480	0698-3136
A6A1R23	0757-0421	1	R:FXD MET FLM 825 OHM 1% 1/8W	28480	0757-0421
A6A1R24	0757-0123		R:FXD MET FLM 34.8K OHM 1% 1/8W	28480	0757-0123
A6A1R25	0698-3161		R:FXD MET FLM 38.3K OHM 1% 1/8W	28480	0698-3161
A6A1R26	0757-0441	1	R:FXD MET FLM 8.25K OHM 1% 1/8W	28480	0757-0441
A6A1R27	0698-0084		R:FXD MET FLM 2.15K OHM 1% 1/8W	28480	0698-0084
A6A1R28	0698-3449		R:FXD MET FLM 28.7K OHM 1% 1/8W	28480	0698-3449
A6A1R29	0698-3450	1	R:FXD MET FLM 42.2K OHM 1% 1/8W	28480	0698-3450
A6A1R30	0757-0278		R:FXD MET FLM 1.78K OHM 1% 1/8M	28480	0757-0278
A6A1R31	0757-0419	4	R:FXD MET FLM 681 OHM 1% 1/8W	28480	0757-0419
A6A1R32	0698-3449		R:FXD MET FLM 287.K OHM 1% 1/8W	28480	0698-3449
A6A1R33	0757-0802		R:FXD MET FLM 162 OHM 1% 1/2W	28480	0757-0802
A6A1T1	9100-1698	1	TRANSFORMER: PULS	28480	9100-1698
A7	08553-6003	1	VTO ASSY: 200-310MHZ	28480	08553-6003
A7C1	0160-3005		C:FXD FEED-THRU 5000 PF +80-20%	28480	0160-3005
A7C2	0160-3005		C:FXD FEED-THRU 5000 PF +80-20%	28480	0160-3005
A7J1	1250-0830		CONNECTOR: RF	98291	50-047-0000
A7J2	1250-0830		CONNECTOR: RF	98291	50-047-0000
A2J3	1250-0830		CONNECTOR: RF	98291	50-047-0000
A7J4	1250-0830		CONNECTOR: RF	98291	50-047-0000
A7MP1	08553-2030	1	COVER: VTO	28480	08553-2030
A7A1	08553-6053	1	BOARD ASSY: VTO	28480	08553-6053
A7A1C1	0150-0073		C:FXD CER 100 PF 10% 100VDCW	56289	C0288102E101KS27-CDH
A7A1C2	0150-0073		C:FXD CER 100 PF 10% 1000VDCW	56289	C0288102E101KS27-COH
A7A1C3	0140-0069	2	C:FXD MICA 550 PF 10% 500VDCW	00853	TYPE M 100E10
A7A1C4	0140-0069		C:FXD MICA 550 PF 10% 500VDCW	00853	TYPE M 100E10

See introduction to this section for ordering information

Table 6-3. Replaceable Parts

Reference Designation	HP Part Number	Qty	Description	Mfr Code	Mfr Part Number
A7A1C5	0160-2327	3	C:FXD CER 1000 PF 20% 100VDCW	96733	8104BX102M
A7A1C6	0122-0042	1	C:VOLTAGE VAR 15.9 PF +/-2% AT 6V	28480	0122-0042
A7A1C7	0160-2327		C:FXD CER 1000 PF 20% 100VDCW	96733	81048X102M
A7A1C8	0150-0050	22	C:FXD CER 1000 PF +80-20% 1000VDCW	56289	C0678102E10ZZS26-CDM
A7A1C9	0160-3240	2	C:FXD PORC 39 PF 5% 500VDCW	95275	VY10CA390JR
A7A1C10	0180-0137	1	C:FXD ELECT 100 UF 20% 10VDCW	56289	150D1107X001OR2-DYS
A7A1C11	0160-3240		C:FXD PORC 39 PF 5% 500VDCW	95275	VV10CA390JR
A7A1C12	0150-0050		C:FXD CER 1000 PF +80-20% 100VDCW	56289	C0678102E10ZZ26-CDH
A7A1C13	0160-2256	1	C:FXD CER 9.1 PF 500VDCW	72982	301-000-COK0-919C
A7A1C14	0180-0050		C:FXD CER 1000 PF +80-20% 1000VDCW	56289	C0678102E10ZS26-CDH
A7A1C15	0150-0050		C:FXD CER 1000 PF +80-20% 1000VDCW	56289	C0678102E10ZS26-CDH
A7A1C16	0150-0050		C:FXD CER 1000 PF +80-20% 1000VDCW	56289	C0678102E10ZS26-CDH
A7A1C17	0150-0073		C:FXD CER 100 PF 10% 1000VDCW	56289	C0288102E101KS27-CH
A7A1C18	0180-0050		C:FXD CER 1000 PF +80-20% 1000VDCW	56289	C0678102E10ZS26-CDH
A7A1C19	0160-2257	2	C:FXD CER 10 PF 5% 500VDCW	12982	301-000-COHO-100J
A7A1C20	0150-0050		C:FXD CER 1000 PF +80-20% 1000VDCW	56289	C0678102E10ZS26-CDH
A7A1C21	0180-0050		C:FXD CER 1000 PF +80-20% 1000VDCW	56289	C0678102E10ZS26-CDH
A7A1C22	0180-0050		C:FXD CER 1000 PF +80-20% 1000VDCW	56289	C0678102E10ZS26-CDH
A7A1C23	0160-2265	4	C:FXD CER 22 PF 5% 500VDCW	72982	301-NPO-22PF
A7A1C24	0150-0050		C:FXD CER 1000 PF +80-20% 1000VDCW	56289	C0678102E10ZS26-CDH
A7A1C25	0150-0080		C:FXD CER 1000 PF +80-20% 1000VDCW	56289	C0678102E10ZS26-CDH
A7A1C26	0150-0050		C:FXD CER 1000 PF +80-20% 1000VDCW	56289	C0678102E10ZS26-CDH
A7A1C27	0160-2262	1	C:FXD CER 16 PF 3% 500VDCW	72982	301-000-COGO 160J
A7A1C28	0150-0050		C:FXD CER 1000 PF +80-20% 1000VDCW	56289	C0678102E10ZS26-CDH
A7A1C29	0150-0050		C:FXD CER 1000 PF +80-20% 1000VDCW	56289	C0678102E10ZS26-CDH
A7A1C30	0160-2255	1	C:FXD CER 8.2 PF 5% 500VDCW	72982	301-000-COHO-829C
A7A1C31	0160-2263	3	C:FXD CER 18 PF 5% 500VDCW	72982	301-000-COGO-180J
A7A1C32	0160-2265		C:FXD CER 22 PF 5% 500VDCW	72982	301-NPO-22PF
A7A1C33	0160-2263		C:FXD CER 18 PF 5% 500VDCW	72982	301-000-COGO-180J
A7A1C34	0160-2258	1	C:FXD CER 11 PF 5% 500VDCW	72982	301-000-COGO-110J
A7A1C35	0160-0050		C:FXD CER 1000 PF +80-20% 1000VDCW	56289	C0678102E 02S26-CDH
A7A1C36	0180-0116		C:FXD ELECT 6.8 UF 10% 35VDCW	56289	1500685X903582-DYS
A7A1C37	0150-0050		C:FXD CER 1000 PF +80-20% 1000VDCW	56289	C0678102E10Z1ZS26-COH
A7A1C38	0180-0116		C:FXD ELECT 6.8 UF 10% 35VDCW	56289	1500685X903582-DYS
A7A1C39	0100-0059	1	C:FXD CER 3.3-0.25 PF 500VDCW	12982	301-000-COJO-339C
A7A1C40	0160-2327		C:FXD CER 1000 PF 20% 100VDCM	96733	81048X102M
A7A1CR1	1901-0347	2	DIODE: SILICON 8V	28480	1901-0347
A7A1CR2	1901-0341		DIODE: SILICON 8V	28480	1901-0347
A7A1CR3	1910-0016		DIODE: GERMANIUM 100MA/0.85V 60PIV	93332	02361
A7A1CR4	1910-0016		DIODE: GERMANIUM 100MA/0.85V 60PIV	93332	02361
A7A1L1	9140-0141	14	COIL: FXD RF 0.68 UH	28480	9140-0141
A7A1L2	9140-0141		COIL: FXD RF 0.68 UH	28480	9140-0141
A7A1L3	9140-0141		COIL:FXD RF 0.68 UH	28480	9140-0141
A7A1L4	08553-6015	1	INDUCTOR:FXD (CW) GREEN	28480	08553-6015
A7A1L5	08553-6016	1	INDUCTOR:FXD(CCW) BLUE	28480	08553-6016
A7A1L6	9140-0141		COIL: FXD RF 0.68 UH	28480	9140-0141
A7A1L7	9140-0141		COIL: FXD RF 0.68 UH	28480	9140-0141
A7A1L8	9140-0141		COIL: FXD RF 0.68 UH	26480	9140-0141
A7A1L9	9140-0141		COIL: FXD RF 0.68 UH	28480	9140-0141
A7A1L10	9140-0141		COIL: FXD RF 0.68 UH	26480	9140-0141
A7A1L11	9140-0141		COIL: FXD RF 0.68 UH	28480	9140-0141
A7A1L12			NSR: PART OF 80 ASSY, TYPICAL VALUE 27NH		
A7A1L13	9140-0141		COIL: FXD RF 0.68 UN	28480	9140-0141
A7A1L14			NSR: PART OF 80 ASSY, TYPICAL VALUE 27NH		
A7A1L15			NSR: PART OF 80 ASSY, TYPICAL VALUE 27NH		
A7A1L16			NSR: PART OF 80 ASSY, TYPICAL VALUE 27NH		
A7A1L17			NSR: PART OF 80 ASSY, TYPICAL VALUE 27NH		
A7A1L18	9140-0141		COIL: FXD RF 0.68 UN	28480	9140-0141
A7A1L19	9140-0129		COIL: FXD RF 220 UH	28480	9140-0129
A7A1L20	9140-0141		COIL: FXD RF 0.68 UH	28480	9140-0141
A7A1L21	9140-0129		COIL: FXD RF 220 UH	28480	9140-0129
A7A1Q1	1854-0345	5	TSTR: S1 NPN	80131	2N5179
A7A1Q2	1854-0345		TSTR: S1 NPN	80131	2N5179
A7A1Q3	1854-0345		TSTR: S1 NPN	80131	2N5179
A7A1Q4	1854-0021	1	TSTR: S1 NPN	80131	2N918
A7A1Q5	1954-0345		TSTR: S1 NPN	80131	2N5179
A7A1Q6	1854-0247	1	TSTR: S1 NPN	28480	1854-0247
A7A1R1	1200-0173	3	PAD: TRANSISTOR MOUNTING	28480	1200-0173
A7A1R2	0757-0416	1	R:FXD MET FLM 511 OHM 1% 1/8W	28480	0757-0416
A7A1R3	0757-0290	1	R:FXD MET FLM 6.19K OHM 1% 1/8W	20480	0757-0290
A7A1R4	2100-1758		FACTORY SELECTED PART		
A7A1R5	0757-0440	1	R:VAR WW 1K OHM 5% TYPE V 1W	28480	2100-1758
A7A1R6	0757-0428	1	R:FXD MET FLM 7.50K OHM 1% 1/8W	28480	0757-0440
A7A1R7	0757-0416	1	R:FXD MET FLM 1.62K OHM 1% 1/8W	28480	0757-0428
A7A1R8	0757-0416		R:FXD MET FLM 511 OHM 1% 1/8W	28400	0757-0416

See introduction to this section for ordering information

Table 6-3. Replaceable Parts

Reference Designation	HP Part Number	Qty	Description	Mfr Code	Mfr Part Number
A7A1R7	0757-0317	1	R:FXD MET FLM 1.33K OHM 1% 1/8W	28480	0757-0317
A7A1R8	0698-3406	3	R:FXD MET FLM 1.33K OHM 1% 1/2W	28480	0698-3406
A7A1R9	0698-3346	1	R:FXD MET FLM 4.22K OHM 1% 1/2W	28480	0698-3346
A7A1R10	0757-0158	1	R:FXD MET FLM 619 OHM 1% 1/2W	28480	0757-0158
A7A1R11	0757-0819	1	R:FXD MET FLM 909 OHM 1% 1/2W	28480	0757-0819
A7A1R12	0698-3442	1	R:FXD MET FLM 237 OHM 1% 1/8W	28480	0698-3442
A7A1R13	0757-0814	1	R:FXD MET FLM 511 OHM 1% 1/2W	28480	0757-0814
A7A1R14	0757-0398	1	R:FXD MET FLM 75 OHM 1% 1/8W	28480	0757-0398
A7A1R15	0683-0275	2	R:FXD COMP 2.7 OHM 5% 1/4W	01121	CB 27G6
A7A1R16	0698-3406	1	R:FXD MET FLM 1.33K OHM 1% 1/2W	28480	0698-3406
A7A1R17	0698-0082	1	R:FXD MET FLM 464 OHM 1% 1/8W FACTORY SELECTED PART	28480	0698-0082
A7A1R18	0757-0418	1	R:FXD MET FLM 619 OHM 1%1/8W	28480	0757-0418
A7A1R19	0698-3434	1	R:FXD MET FLM 34.8 OHM 1% 1/8W FACTORY SELECTED PART	28480	0698-3434
A7A1R20	0757-0798	1	R:FXD MET FLM 110 OHM 1% 1/2W	28480	0757-0798
A7A1R21	0757-0398	1	R:FXD MET FLM 75 OHM 1% 1/8W	28480	0757-0398
A7A1R22	0683-0275	1	R:FXD COMP 2.7 OHM 5% 1/4W FACTORY SELECTED PART	01121	CB 27G5
A7A1R23	0698-3406	1	R:FXD MET FLM 1.33K OHM 1% 1/2W	28480	0698-3406
A7A1R24	0698-3132	1	R:FXD FLM 261 OHM 1% 1/8W FACTORY SELECTED PART	28480	0698-3132
A7A1R25	0698-3441	3	R:FXD MET FLM 2.15 OHM 1% 1/8W	28480	0698-3441
A7A1R26	0757-0419	1	R:FXD MET FLM 681 OHM 1% 1/8w	28480	0757-0419
A7A1R27	0698-3378	1	R:FXD CARBON 51 OHM 5% 1/8W	28480	0698-3378
A7A1R28	0698-0084	1	R:FXD MET FLM 2.15K OHM 1% 1/8W FACTORY SELECTED PART	28480	0698-0084
A7A1T1	08552-6018	4	TRANSFORMER: RF(CODE-RED)	28480	08552-6018
A7A1T2	08552-6018	1	TRANSFORMER: RF (CODE RED)	28480	08552-6018
A7A1T3	08552-6018	1	TRANSFORMER: RF (CODE-RED)	28480	08552-6018
A7A1T4	08552-6018	1	TRANSFORMER: RF (CODE RED)	28480	08552-6018
A8	08553-60131	1	REFERENCE ASSY	28480	08553-60131
A8C1	0160-3005	1	C:FXD FEED-THRU 5000 PF +80-20%	28480	0160-3005
A8C2	0160-3075	1	C:FXD CER FEED-THRU 100PF 20% 500VDCW	28480	0160-3075
A8C3	0160-3005	1	C:FXD FEED-THRU 5000 PF +80-20%	28480	0160-3005
A8C4	0160-3005	1	C:FXD FEED-THRU 5000 PF +80-20%	28480	0160-3005
ABC5	0160-3005	1	C:FXD FEED-THRU 5000 PF +80-20%	28480	0160-3005
A8J1	1250-0830	1	CONNECTOR: RF	98291	50-047-0000
A8MP1	08553-20131	1	COVER: REFERENCE ASSY	28480	08553-20131
A8A1	08553-60128	1	BOARD ASSY: REFERENCE	28480	08553-60128
A8A1C1-			NOT ASSIGNED		
A8A1C5					
A8A1C6	0180-0116		C:FXD ELECT 6.8 UF 10% 35VDCW	56289	1500685X903582-DYS
A8A1C7	0180-0116		C:FXD ELECT 6.8 UF 10% 35VDCW	56289	1500685X903582-DYS
A8A1C8	0160-2930		C:FXD CER 0.01 UF +80-20% 100VDCW	91418	TA
A8A1C9	0180-0116		C:FXD ELECT 6.8 UF 10% 35VDCW	56289	1500685X903582-DYS
A8A1C10	0160-2930		C:FXD CER 0.01 UF +80-20% 100VDCW	91418	TA
A8A1C11	0140-0193	1	C:FXD MICA 82 PF 5%	28480	0140-0193
A8A1C12	0160-2307	1	C:FXD MICA 47 PF 5%	28480	0160-2307
A8A1C13	0160-0337	1	C:FXD MICA 160 PF 1%	28480	0160-0337
A8A1C14	0160-2208	1	C:FXD MICA 330 PF 5% 300VDCW	28480	0160-2208
ASA1C15	0160-2266		C:FXD CER 24 PF 5% 500VDCW	72982	301-000-COGO-240J
A8A1C16	0140-0197	2	C:FXD MICA 180 PF 5% 300VDCW	14655	RDM151F181J3C
A8A1C17	0140-0197	1	C:FXD MICA 180 PF 5% 300VDCW	14655	RDM151F181J3C
A8A1C18	0160-2266		C:FXD CER 24 PF 5% 500VDC	72982	301-000-COGO-240J
A8A1C19	0180-0228	2	C:FXD ELECT 22 UF 10% 15VDCW	56289	150D226X901582-DYS
A8A1C20	0150-0121		C:FXD CER 0.1 UF +80-20% 50VDCW	56289	5C50BIS-CML
A8A1C21	0180-0197		C:FXD ELECT 2.2 UF 10% 20VDCW	56289	150D225X9020A2-DYS
A8A1C22	0160-2930		C:FXD CER 0.01 UF +80-20% 100VDCW	91418	TA
A8A1C23	0170-0069	1	C:FXD POLY 0.1 UF 2% 50VDCW	56289	114P1042R5S3
A8A1C24	0180-2214	1	C:FXD ELECT 90 UF +75-10% 15VDCW	56289	30D906G015CC2-DSM
A8A1C25	0180-0228		C:FXD ELECT 22 UF 10% 15VDCW	56289	1500226X901582-DYS
A8A1CR1	1901-0049		DIODE: SILICON 50PIV	28480	1901-0049
A8A1CR2	1901-0049		DIODE: SILICON 50PIV	28480	1901-0049
A8A1CR3	1901-0040		DIODE: SILICON 30MA 30VV	07263	FDG1088
A8A1CR4	1901-0040		DIODE: SILICON 30MA 30VV	07263	FDG1088
A8A1CR5	1901-0040		DIODE: SILICON 30MA 30VV	07263	FDG1088
A8A1CR6	1901-0040		DIODE: SILICON 30MA 30VV	07263	FDG1088
A8A1CR7	1901-0040		DIODE: SILICON 30MA 30VV	07263	FDG1088
A8A1CR8	1901-0040		DIODE: SILICON 30MA 30VV	07263	FDG1088
A8A1CR9	1910-0016		DIODE: GERMANIUM 100MA/0.85V 60PIV	93332	D2361
A8A1CR10	1901-0025		DIODE: SILICON 100MA/1V	07263	FD 2387
A8A1K1	0490-0399	1	RELAY: REED ASSY, 1200 OHM 12VDC	28480	0490-0399
A8A1L1	9140-0129		COIL: FXD RF 220 UH	28480	9140-0129

See introduction to this section for ordering information

Table 6-3. Replaceable Parts

Reference Designation	HP Part Number	Qty	Description	Mfr Code	Mfr Part Number
A8A1L2	9140-0129		COIL IFXD RF 220 UH	28480	9140-0129
A8AMP1	0340-0008	1	INSULATOR:STANDOFF TEFLON	98291	ST-1000-L2
A8A1MP2	0360-0124		TERMINAL: SOLDER LUG	28480	0360-0124
A8SAQ1	1855-0098	1	TSTR:SI FEET	28480	1855-0098
A8A1Q2	1854-0042	2	TSTR:SI NPN	28480	1854-0042
A8A1Q3	1854-0042		TSTR:SI NPN	28480	1854-0042
A8A1Q4	1853-0034		TSTR:SI PNP(SELECTED FROM 2N3251)	28480	1853-0034
A8A1Q5	1854-0019	1	TSTR:SI NPN	28480	1854-0019
A8A1Q6	1853-0034		TSTR:SI PNP(SELECTED FROM 2N3251)	28480	1853-0034
A8A1Q7	1854-0009	3	TSTR:SI NPN	80131	2N709
A8A1Q8	1854-0009		TSTR:SI NPN	80131	2N709
A8A1Q9	1854-0009		TSTR:SI NPN	80131	2N709
A8A1Q10	1854-0071		TSTR:SI NPN(SELECTED FROM 2N3704)	28480	1854-0071
A8A1Q11	1854-0C71		TSTR:SI NPN(SELECTED FROM 2N3704)	28480	1854-0071
A8A1Q12	1853-0020		TSTR:SI PNP(SELECTED FROM 2N3702)	28480	1853-0020
A8A1Q13	1853-0020		TSTR:SI PNP(SELECTED FROM 2N3702)	28480	1853-0020
A8A1Q14	1853-0020		TSTR:SI PNP(SELECTED FROM 2N3702)	28480	1853-0020
A8A1R1	0757-0405	1	R:FXD MET FLM 162 OHM 1% 1/8W	28480	0757-0405
A8A1R2	0698-3154		R:FXD MET FLM 4.22K OHM 1% 1/8W	28480	0698-3154
A8A1R3	0698-0084		R:FXD MET FLM 2.15K OHM 1% 1/8W	28480	0698-0084
A8A1R4	0757-0280		R:FXD MET FLM 1K OHM 1% 1/8W	28480	0757-0280
A8A1R5	0698-3154		R:FXD MET FLM 4.22K OHM 1% 1/8W	28480	0698-3154
A8A1R6	0698-0084		R:FXD MET FLM 2.15K OHM 1% 1/8M	28480	0698-0084
A8A1R7	0757-0280		R:FXD MET FLM 1K OHM 1% 1/8 W	28480	0757-0280
A8A1R8	0757-0280		R:FXD MET FLM 1K OHM 1% 1/8W	28480	0757-0280
A8A1R9	0757-0278		R:FXD MET FLM 1.78K OHM 1% 1/8W	28480	0757-0278
A8A1R10	0698-3152		R:FXD MET FLM 3.48K OHM 1% 1/8W	28480	0698-3152
A8A1R11	0757-0199		R:FXD MET FLM 21.5K OHM 1% 1/8W	28480	0757-0199
A8A1R12	0698-3152		R:FXD MET FLM 3.48K OHM 1% 1/8W	28480	0698-3152
A8A1R13	0757-0416		R:FXD MET FLM 511 OHM 1% 1/8W	28480	0757-0416
A8A1R14	0698-3161		R:FXD MET FLM 38.3K OHM 1% 1/8W	28480	0698-3161
A8A1R15	0698-3442		R:FXD MET FLM 237 OHM 1% 1/8W	28480	0698-3442
A8A1R16	0698-3442		R:FXD MET FLM 237 OHM 1% 1/8W	28480	0698-3442
A8A1R17	0757-0280		R:FXD MET FLM 1K OHM 1% 1/8W	28480	0757-0280
A8A1R18	0698-3447	2	R:FXD MET FLM 422 OHM 1% 1/8W	28480	0698-3447
A8A1R19	0757-0280		R:FXD MET FLM 1K OHM 1% 1/8W	28480	0757-0280
A8A1R20	0757-0417	2	R:FXD MET FLM 562 OHM 1% 1/8W	28480	0757-0417
A8A1R21	0698-3154		R:FXD MET FLM 4.22K OHM 1% 1/8W	28480	0698-3154
A8A1R22	0757-0280		R:FXD MET FLM 1K OHM 1% 1/8W	28480	0757-0280
A8A1R23	0757-0417		R:FXD MET FLM 562 OHM 1% 1/8W	28480	0757-0417
A8A1R24	0698-3154		R:FXD MET FLM 4.22K OHM 1% 1/8W	28480	0698-3154
A8A1R25	0757-0394		R:FXD MET FLM 51.1 OHM 1% 1/8W	28480	0757-0394
A8A1R26	0698-3449		R:FXD MET FLM 28.7K OHM 1% 1/8W	28480	0698-3449
A8A1R27	0757-0288	1	R:FXD MET FLM 9.09K OHM 1% 1/8W	28480	07571-0288
A8A1R28	0757-0467		R:FXD MET FLM 121K OHM 1% 1/8W	28480	0757-0467
A8A1R29	0698-3161		R:FXD MET FLM 38.3K OHM 1% 1/8W	28480	0698-3161
A8A1R30	0757-0442		R:FXD MET FLM 10.0K OHM 1% 1/8W	28480	0757-0442
A8A1R31	0757-0199		R:FXD MET FLM 21.5K OHM 1% 1/8W	28480	0757-0199
A8A1R32	0698-3160		R:FXD MET FLM 31.6K OHM 1% 1/8W	28480	0698-3160
A8A1R33	0757-0458	1	R:FXD MET FLM 51.1K OHM 1% 1/8W	28480	0757-0458
A8A1R34	0683-8245		R:FXD COMP 820K OHM 5% 1/4W	01121	CB 8245
A8A1R35	0683-9145		R:FXD COMP 910K OHM 5% 1/4W	01121	CB 9145
A8A1R36	0757-0466	1	R:FXD MET FLN 110K OHM 1% 1/8W	28480	0757-0466
A8A1R37	0757-C279		R:FXD MET FLN 3.16K OHM 1% 1/8W	28480	0757-0279
A8A1R38	0698-3136		R:FXD MET FLN 17.8K OHM 1% 1/8W	28480	0698-3136
A8A1R39	0757-0280		R:FXD MET FLM 1K OHM 1% 1/8W	28480	07571-0280
A8A1R40	0698-3154		R:FXD MET FLM 4.22K OHM 1% 1/8W	28480	0698-3154
A8A1XY1	1200-0770	1	SOCKET:CRYSTAL	91506	8000-AG-26
A8A1Y1	0410-0013	1	CRYSTAL:QUARTZ 1MHZ	28480	0410-0013
A9	08553-6004	1	200 MHZ IF ASSY	28480	08553-6004
A9C1	0160-3005		C:FXD FEED-THRU 5000 PF +80-20%	28480	0160-3005
A9J1	1250-0943	3	CONNECTOR:RF SUB-MINIATURE	98291	50-075-0099
A9J2	1250-0943		CONNECTOR:RF SUB-MINIATURE	98291	50-075-0099
A9J3	1250-0943		CONNECTOR:RF SUB-MINIATURE	98291	50-075-0099
A9MP1	08553-2032	1	COVER:200MHZ IF	28480	08553-2032
A9A1	08553-6054	1	200 MHZ IF AMPLIFIER	28480	08553-6054
A9A1C1			NOT ASSIGNED		
A9A1C2	0160-2140	5	C:FXD CER 470 PF +80-20% 1000VDCW	91418	TYPE B
A9A1C3	0160-2140		C:FXD CER 470 PF +80-20% 1000VDCW	91418	TYPE B
A9A1C4	0160-2140		C:FXD CER 470 PF +80-20% 1000VDCW	91418	TYPE B
A9A1C5	0160-0419	2	C:FXD CER 1000 PF +80-20% 500VDCW	01121	SSSA-102W
A9A1C6	0180-0197		C:FXD ELECT 2.2 UF 10% 20VDCW	56289	150D225X9020A2-DYS
A9A1C7	0160-2140		C:FXD CER 470 PF +80-20% 1000VDCW	91418	TYPE B
A9A1C8	0121-00369	2			

See introduction to this section for ordering information

Table 6-3. Replaceable Parts

Reference Designation	HP Part Number	Qty	Description	Mfr Code	Mfr Part Number
A9A1C8			FACTORY SELECTED PART		
A9A1C9	0160-2140		C:FXD CER 470 PF +80-20% 1000VDCW	91418	TYPE B
A9A1C10	0160-3020	1	C:FXD CER 3.9+/-0.1 PF 500VDCW	72982	301-000-COJO-3998
A9A1C11	0160-0419		C:FXD CER 1000 PF +80-20% 500VDCW	01121	SS5A-102W
A9A1C12	0180-0197		C:FXD ELECT 2.2 UF 10% 20VDCW	56289	150D225X9020A2-DYS
A9A1C13	0160-3498	1	C:FXD CER 27 PF 53 500VDCW	72982	301-000-P2G 270J
A9A1CR1	1902-3104		DIODE:BREAKDOWN 5.62V 5%	04713	SZ10939-110
A9A1CR2	1902-3104		DIODE:BREAKDOWN 5.62V 5%	04713	SZ10939-110
A9A1J1	1250-0836		CONNECTOR:RF SUB-MINIATURE	98291	50-053-0000
A9A1L1	9100-1611		COIL:FXD 0.22 UH 20%	28480	9100-1611
A9A1L2	9100-1611		COIL:FXD 0.22 UH 20%	28480	9100-1611
A9A1L3	9140-0141		COIL:FXD RF 0.68 UH 5%	28480	9140-0141
A9A1L4			NOT ASSIGNED		
A9A1L5	9100-1611		COIL:FXD 0.22 UN 20%	28480	9100-1611
A9A1L6	9140-0158	2	COIL:FXD RF 1 UH 10%	99800	1025-20
A9A1L7	9140-0141		COIL:FXD RF 0.68 UH	28480	9140-0141
A9A1L8	9100-2817	2	COIL/CHOKE 0.1 UH 5%	13019	4416-1J
A9A1L9	9140-0158		COIL:FXD RF 1 UH 10%	99800	1025-20
A9A1L10	9100-2817		COIL/CHOKE 0.1 UH 5%	13019	4416-1J
A9A1L11	9100-1610	1	COIL:MOLDED CHOKE 0.15 UH 20%	28480	9100-1610
A9A1Q1	1854-0435	2	TSTR:SI NPN	28480	18540435
A9A1Q1	1200-0173		PAD:TRANSISTOR MOUNTING	28480	1200-0173
A9A1Q2	1854-0435		TSTR:SI NPN	28480	1854-0435
A9A1Q2	1200-0173		PAD:TRANSISTOR MOUNTING	28480	1200-0173
A9A1R1	0698-3402	2	R:FXD MET FLM 316 OHM 1% 1/2W	28480	0698-3402
A9A1R2	0698-3441		R:FXD MET FLM 215 OHM 1% 1/8W	28480	0698-3441
A9A1R3	0757-0346		R:FXD MET FLM 10 OHM 1% 1/8W	28480	0757-0346
A9A1R4	0698-3402		R:FXD MET FLM 316 OHM 1% 1/2W	28480	0698-3402
A9A1R5	0698-3441		R:FXD MET FLM 215 OHM 1% 1/8W	28480	0698-3441
A9A1R6	0757-0346		R:FXD MET FLM 10 OHM 1% 1/8W	28480	0757-0346
A9A1R7	0757-0416		R:FXD MET FLM 511 OHM 1% 1/8W	28480	0757-0416
A9A1R7			FACTORY SELECTED PART		
A9A2	08553-6002	1	FIRST CONVERTER ASSY	28480	08553-6002
A9A2C1	0160-2260	1	C:FXD CER 13 PF 5% 500VDCW	72982	301-000-COJO 130J
A9A2C2	0160-2241	1	C:FXD CER 2.2 PF 50VDCW	72982	301-000-COJO-229C
A9A2C2			FACTORY SELECTED PART		
A9A2CR1	1901-0050	2	DIODE:SI 200 MA AT 1V	07263	FDA 6308
A9A2CR2	1901-0050		DIODE:SI 200 MA AT 1V	07263	FDA 6308
A9A2CR3	5080-0271	2	DIODE:SILICON MATCHED QUAD	28480	5080-0271
A9A2CR4			PART OF A9A2CR3		
A9A2CR5			PART OF A9A2CR3		
A9A2CR6			PART OF A9A2CR3		
A9A2P1	1250-1006	3	CONNECTOR:RF SUB-MINIATURE	98291	50-044-0000
A9A2P2	1250-1006		CONNECTOR:RF SUB-MINIATURE	98291	50-044-00
A9A2P3	1250-0930	1	CONNECTOR:RF SUB-MINIATURE	98291	50-048-0000
A9A2R1	0698-7212	1	R:FXD FLM 100 OHM 2% 1/8W	28480	0698-7212
A9A2T1	08552-6024	4	TRANSFORMER:RF (CODE=YELLOW)	28480	08552-6024
A9A2T2	08553-6012	4	TRANSFORMER:RF (CODE=BLUE)	28480	08553-6012
A9A2T3	08553-6012		TRANSFORMER:RF (CODE=BLUE)	28480	08553-6012
A9A2T4	08552-6024		TRANSFORMER:RF (CODE=YELLOW)	28480	08552-6024
A9A2			MISCELLANEOUS		
A9A2	0380-0610	2	STANDOFF:0.437" LG	01255	153087/16-11
A9A2	08553-0026	2	SHIELD COVER:FIRST MIXER	28480	08553-0026
A9A2	08553-0027	2	INSULATOR:FIRST MIXER	28480	08553-0027
A9A2A	08553-0029	1	SHIELD CAN:FIRST MIXER	28480	08553-0029
A9A3	08553-6006	1	200 MHZ BP FILTER ASSY	28480	08553-6006
A9A3C1	0160-3121	2	C:FXD CER 15 PF 10% 500VDCW	01121	FB28 1501
A9A3C2	0160-2266		C:FXD CER 24 PF 5% 500VDCW	72982	301-000-COJO-240J
A9A3C3	0121-0048		C:VAR GL 0.8-8.5 PF 750VDCW	73899	VC9GW
A9A3C4	0160-2257		C:FXD CER 10 PF 5% 500VDCW	72982	301-000-COHO-100J
A9A3C5	0121-0048		C:VAR GL 0.8-8.5 PF 750VDCW	73899	VC96W
A9A3C6	0121-0048		C:VAR GL 0.8-8.5 PF 750VDCW	73899	VC9GW
A9A3C7	0160-2266		C:FXD CER 24 PF 5% 500VDCW	72982	301-000-COJO-240J
A9A3C8	0160-3121		C:FXD CER 15 PF 10% 500VDCW	01121	F82R 1501
A9A3L1	08553-6018	2	INDUCTOR ASSY:AIR CORE	28480	08553-6018
A9A3L2	08553-6017	1	INDUCTOR ASSY:200MHZ	28480	05536017
A9A3L3	08553-6018		INDUCTOR ASSY:AIR CORE	28480	08553-6018
A9A3P1	1250-1006		CONNECTOR:RF SUB-MINIATURE	98291	50-044-0000
A9A3			MISCELLANEOUS		
A9A3	2190-0057	2	WASHER:LOCK FOR #12 HDW	00000	08D
A9A3	0590-0060	1	NUT:HEX 12-32 UNEF-28	01121	M-6377
A9A3	0380-0810		STANDOFF:0.4371 LG	01255	153087/16-11

See introduction to this section for ordering information

Table 6-3. Replaceable Parts

Reference Designation	HP Part Number	Qty	Description	Mfr Code	Mfr Part Number
A9A3	08553-0025	1	SHIELD CAN:200MHZ FILTER	28480	08553-0025
A9A3	08553-0026		SHIELD COVER:FIRST MIXER	28480	08553-0026
A9A3	08553-0027		INSULATOR:FIRST MIXER	28480	08553-0027
A9A3	08553-0028	1	GROUND BRACKET:200MHZ FILTER	28480	08553-0028
A10	08553-60132	1	SECOND CONVERTER ASSY	28480	08553-60132
A10C1	0160-3005		C:FXD FEED-THRU 5000 PF +80-20%	28480	0160-3005
A10J1	1250-0830		CONNECTOR:RF	98291	50-047-0000
A10J2	1250-0830		CONNECTOR:RF	98291	50-047-0000
A10J3	1250-0830		CONNECTOR:RF	98291	50-047-0000
A10MP1	08553-20132	1	COVER:SECOND CONVERTER	28480	08553-20132
A10A1	08553-60129	1	BOARD ASSY:150 MHZ OSCILLATOR	28480	08553-60129
A10A1C1			NOT ASSIGNED		
A10A1C2	0150-0050		C:FXD CER 1000 PF +80-20% 1000VDCW	56289	C067B102E102ZS26-CDH
A10A1C3	0150-0050		C:FXD CER 1000 PF +80-20% 1000VDCW	56289	C067B102E102ZS26-CDH
A10A1C4	0150-0050		C:FXD CER 1000 PF +80-20% 1000VDCW	56289	C067B102E102ZS26-CDH
A10A1C5	0160-2263		C:FXD CER 18 PF 5% 500VDCW	72982	301-000-COGO-180J
A10A1C6	0160-2266		C:FXD CER 24 PF 5% 500VDCW	72982	301-000-COGO-240J
A10A1C7	0160-2139	2	C:FXD CER 220 PF +80-20% 1000VDCW	91418	TYPE B
A10A1C8	0150-0050		C:FXD CER 1000 PF +80-20% 1000VDCW	56289	C067B102E102ZS26-CDH
A10A1C9	0160-2139		C:FXD CER 220 PF +80-20% 1000VDCW	91418	TYPE B
A10A1C10	0150-0050		C:FXD CER 1000 PF +80-20% 1000VDCW	56289	C067B102E102ZS26-CDH
A10A1C11	0150-0050		C:FXD CER 1000 PF +80-20% 1000VDCW	56289	C067B102E102ZS26-CDH
A10A1CR1	1902-3025	1	DIODE BREAKDOWN:2.87V 2%	28480	1902-3025
A10A1L1	9140-0096	3	COIL:FXD RF 1 UH	28480	9140-0096
A10A1L2	9140-0096		COIL:FXD RF 1 UH	28480	9140-0096
A10A1L3	08553-6019	1	INDUCTOR ASSY:VAR(7T)	28480	08553-6019
A10A1L4	9100-2250	1	COIL/CHOKE 0.18 UH 10%	28480	9100-2250
A10A1L4			FACTORY SELECTED PART		
A10A1L5	9100-2252	1	COIL/CHOKE 0.27 UH 10%	28480	9100-2252
A10A1L6	9140-0096		COIL:FXD RF 1 UH	28480	9140-0096
A10A1Q1	1854-0233	1	TSTR:SI NPN	80131	2N3866
A10A1Q2	1854-0345		TSTR:SI NPN	80131	2N5179
A10A1R1	0698-7188	1	R:FXD NET FLM 10 OHM 2% 1/8W	28480	0698-7188
A10A1R2	0757-0419		R:FXD MET FLM 681 OHM 1% 1/8W	28480	0757-0419
A10A1R3	0757-0419		R:FXD MET FLM 681 OHM 1% 1/8W	28480	0757-0419
A10A1R4	0698-3437	1	R:FXD MET FLM 133 OHM 1% 1/8W	28480	0698-3437
A10A1R5	0698-3433	2	R:FXD MET FLM 28.7 OHM 1% 1/8W	28480	0698-3433
A10A1R6	0698-3433		R:FXD MET FLM 28.7 OHM 1% 1/8W	28480	0698-3433
A10A1R7	0698-4037	1	R:FXD MET FLM 46.4 OHM 1% 1/8W	28480	0698-4037
A10A1R8	0698-3444		R:FXD MET FLM 316 OHM 1% 1/8W	28480	0698-3444
A10A1R9	0757-0346		R:FXD MET FLM 10 OHM 1% 1/8W	28480	0757-0346
A10A1Y1	0410-0150	1	CRYSTAL:QUARTZ 150MHZ	28480	0410-0150
A10A2	08553-6009	1	MIXER ASSY:SECOND	28480	08553-6009
A10A2C1	0160-0778	2	C:FXD CER 56 PF 10% 500VDCW	01121	F82B
A10A2C2	0160-0778		C:FXD CER 56 PF 10% 500VDCW	01121	F82B
A10A2C3	0160-2264	2	C:FXD CER 20 PF 5% 500VDCW	72982	301-000-COGO-200J
A10A2CR1	5080-0271		DIODE:SILICON HATCHED QUAD	28480	5080-0271
A10A2CR2			PART OF A10A2CR1		
A10A2CR3			PART OF A10A2CR1		
A10A2CR4			PART OF A10A2CR1		
A10A2L1	9100-2249	1	COIL/CHOKE 0.15 UH 10%	28480	9100-2249
A10A2MP1	08553-0022	1	SHIELD:CAN,SECOND MIXER	28480	08553-0022
A10A2MP2	08553-0023	1	SHIELD:COVER,SECOND MIXER	28480	08553-0023
A10A2MP3	08553-0024	1	INSULATOR:SECOND MIXER	28480	08553-0024
A10A2T1	08552-6024		TRANSFORMER:RF(CODE=YELLOW)	28480	08552-6024
A10A2T2	08553-6012		TRANSFORMER:RF(CODE=BLUE)	28480	08553-6012
A10A2T3	08553-6012		TRANSFORMER:RF(CODE=BLUE)	28480	08553-6012
A10A2T4	08552-6024		TRANSFORMER:RF(CODE=YELLOW)	28480	08552-6024
A11	08553-6001	1	FILTER ASSY:INPUT	28480	08553-6001
A11C1	0160-2265		C:FXD CER 22 PF 5% 500VDCW	72982	301-NPO-22PF
A11C2	0160-2261		C:FXD CER 15 PF 5% 500VDCW	72982	301-NPO-15 PF
A11C3	0160-2264		C:FXD CER 20 PF 5% 500VDCW	72982	301-000-COGO-200J
A11C4	0160-2266		C:FXD CER 24 PF 5% 500VDCW	72982	301-000-COGO-240J
A11C5	0160-2261		C:FXD CER 15 PF 5% 500VDCW	72982	301-NPO-15 PF
A11C6	0160-2265		C:FXD CER 22 PF 5% 500VDCW	72982	301-NPO-Z2PF
A11J1	1250-0830		CONNECTOR:RF	98291	50-047-0000
A11J2	1250-0830		CONNECTOR:RF	98291	50-041-0000
A11L1	08553-6013	2	INDUCTOR ASSY:VAR(5-1/2T)	28480	08553-6013
A11L2	08553-6014	2	INDUCTOR ASSY:VAR(7-1/2T)	28480	08553-6014
A11L3	08553-6014		INDUCTOR ASSY:VAR(7-1/2T)	28480	08553-6014
A11L4	08553-6013		INDUCTOR ASSY:VAR(5-1/2T)	28480	08553-6013

See introduction to this section for ordering information

Table 6-3. Replaceable Parts

Reference Designation	HP Part Number	Qty	Description	Mfr Code	Mfr Part Number
A11			MISCELLANEOUS		
A11	08553-0010	1	SHIELD:CAN, INPUT FILTER	28480	08553-0010
A11	08553-0020	1	SHIELD:COVER, INPUT FILTER	28480	08553-0020
A11	08553-0021	1	INSULATOR:INPUT FILTER	28480	08553-0021
A12	08553-6063	1	CAPACITOR ASSY	28480	08553-6036
A13	08553-60123	1	BOARD ASSY:FREQUENCY RANGE	28480	08553-60123
A13MP1	0360-0124		TERMINAL: SOLDER LUG	28480	0360-0124
A13R1	0757-0444		R:FXD MET FLM 12.1K OHM 1% 1/8W	28480	0757-0444
A13R2	2100-1772 2		R:VAR WW 500 OHM 5% TYPE H 1W	28480	2100-1772
A13R3	0757-0278		R:FXD MET FLM 1.78K OHM 1% 1/8W	28480	0757-0278
A13R4	0698-3447		RIFXD MET FLM 422 OHM 1% 1/8W	28480	0698-3447
A13R5	2100-1772		R:VAR WW 500 OHM 5% TYPE H 1W	28480	2100-1772
A14	08553-60122	1	LOAD ASSY:50 OHM	28480	08553-60122

See introduction to this section for ordering information

Table 6-3. Replaceable Parts

Reference Designation	HP Part Number	Qty	Description	Mfr Code	Mfr Part Number
			CHASSIS PARTS		
C1	0150-0093	1	C:FXD CER 0.01 UF +80-20% 100VDCW	72982	801-K800011
CR1	1902-0118	1	DIODE BREAKDOWN: 5.11V	28480	1902-0518
DS1	2140-0259	1	LAMP:INCANDESCENT 12V 0.06A DISPLAY UNCAL	71744	CM8-1099
DS1	1450-0371	1	LENS:LAMPHOLDER, AMBER	08717	102-AILENS)
DS1	1490-0153	1	LAMPHOLDER:FOR T-1 SERIES	08717	102 SR
F1	2110-0001	1	FUSE:1 AMP 250V	75915	312001.
J1	1250-0252	2	BODY:RF CONNECTOR BULKHEAD RECEPTACLE PART OF W1 CABLE ASSY	28480	1250-0252
J2			PART OF I.P.O. NUMBER 55		
J3	1251-2081	1	CONNECTOR:R AND P 41 MALE CONTACT	71468	DMD-43W2-P
MP1	08553-2024	1	HOUSING:RF	28480	08553-2024
MP2	08553-0004	1	COVER:BOTTOM	28480	08553-0004
MP3	08553-0005	1	COVER:TOP	28480	08553-0005
MP4	08553-00112	1	SHIELD:MAGNETIC	28480	08553-00112
MP5	08553-0003	1	BRACKET:MOUNT INPUT FILTER	28480	08553-0003
MP6	5040-0274	1	FOOT PLUG-IN	28480	5040-0274
MP7	08553-0030	1	BRACKET:MOUNT INTERCONNECTOR	28480	08553-0030
P1			NOT ASSIGNED		
P2	1251-0055	1	CONNECTOR:MALE 24 CONTACTS	28480	1251-0055
P3			NOT ASSIGNED		
P4	1251-2366	1	CONNECTOR:R AND P 8 POSITIONS	71468	DCM 8W85
R1	2100-2488	1	R:VAR COMP 10K OHM 20% LIN 1/2W AMP CAL	28480	2100-2488
R2	2100-2528	1	R:VAR CERMET 5K OHM 10% LIN 2W	28480	2100-2528
R2	0310-0116	1	KNOB:BLACK ROUND(FREQUENCY)	28480	0370-0116
R3	2100-2901	1	R:VAR CERNET 2K OHM 10% LIN 2W	28480	2100-2907
R3	0370-0114	1	KNOB:RED W/ARROW 5/8" OD 1/8" SHAFT	28480	0370-0114
R4	0698-0083	1	R:FXD MET FLM 1.96K OHM 1% 1/8W	28480	0698-0083
R5	0757-0279	1	R:FXD MET FLM 3.16K OHM 1% 1/8W	28480	0757-0279
S1	3101-1160	1	SWITCH:SLIDE DPDT MINIATURE TUNING STABILIZER	28480	3101-1560
W1	08553-6062	1	CABLE ASSY:RF INPUT	28480	08553-6062
W1	1250-1167	1	BODY:RF CONNECTOR-ELBOW SUB-MIN.	98291	9436-99
W1	12S0-1174	1	COVER:RF CONNECTOR-ELBOW SUB-MIN.	98291	5561-27
				02660	31-2125-2
				98291	50-028-0139
W2	08553-6037	1	CABLE ASSY:INPUT ATTEN/FILTER	28480	08553-6037
W2	1250-0888	1	CONNECTOR:RF FOR RG-188/U CABLE	98291	50-028-0139
W2	1250-0887	8	CONNECTOR:RF SUB-MINIATURE	98291	50-024-0159
W3	08553-6024	1	CABLE ASSY:INPUT FILTER TO A9J2	28480	08553-6024
W3	1250-0887	1	CONNECTOR:RF SUB-MINIATURE	98291	50-024-0159
W3	1250-0887	1	CONNECTOR:RF SUB-MINIATURE	98291	50-024-0159
W4	08553-6026	1	CABLE ASSY:A7J4 TO A9J3	28480	08553-6026
W4	1250-0888	1	CONNECTOR:RF FOR RG-188/U CABLE	98291	50-028-0139
W4	1250-0888	1	CONNECTOR:RF FOR RG-188/U CABLE	98291	50-028-0139
W5	08553-6027	1	CABLE ASSY:A9J1 TO A10J4	28480	08553-6027
W5	1250-0888	1	CONNECTOR:RF FOR RG-188/U CABLE	98291	50-028-0139
W5	1250-0887	1	CONNECTOR:RF SUB-MINIATURE	98291	50-024-0159
W6	08553-6036	1	CABLE ASSY:50MHZ-A10J1	28480	08553-6036
W6	1250-0118	1	CONNECTOR:8NC	24931	28JR 128-1
W6	1250-0888	1	CONNECTOR:RF FOR RG-188/U CABLE	98291	50-028-0139
W6	1250-0888	1	CONNECTOR:RF FOR RG-188/U CABLE	98291	50-028-0139
W7	08553-6038	1	CABLE ASSY:50MHZ INTERCONNECTOR	28480	08553-6038
W7	1250-0826	1	CONNECTOR:RF	98291	50-027-0000
W7	1251-0179	1	CONNECTOR COAXIAL	71468	DM-53740-5001
W8	08553-6040	1	CABLE ASSY:VTO TUNING	28480	08553-6040
W8	0362-0021	3	SLEEVE:CABLE TERMINATION	00000	OBD
W8	1250-0887	1	CONNECTOR:RF SUB-MINIATURE	98291	50-024-0159
W9	08553-60113	1	CABLE ASSY:1ST L.O. OUTPUT(A7J3 TO P4A2)	28480	08553-60113
W9	1250-0887	1	CONNECTOR:RF SUB-MINIATURE	98291	50-024-0159
W10	08553-6031	1	CABLE ASSY:APC REF.	28480	08553-6035
W10	1250-0887	1	CONNECTOR:RF SUB-MINIATURE	98291	50-024-0159
W10	1250-0887	1	CONNECTOR:RF SUB-MINIATURE	98291	50-024-0159
W11	08553-6025	1	CABLE ASSY:A6J2 TO A8J2	28480	08553-6025
W11	1250-0988	1	CONNECTOR:RF FOR RG-188/U CABLE	98291	50-028-0139
W11	1250-0888	1	CONNECTOR:RF FOR RG-188/U CABLE	98291	50-028-0139
W12	08553-60115	1	CABLE ASSY:P4A3 TO PIN 41J3	28480	08553-60115
W12	0362-0021	1	SLEEVE:CABLE TERMINATION	00000	OBD
W13	08553-6042	1	CABLE ASSY:SWEEP INPUT	28480	08553-6042
W13	0362-0021	1	SLEEVE:CABLE TERMINATION	00000	OBD
W14	08553-60116	1	CABLE ASSY:3RD L.O. OUTPUT	28480	08553-60116
W14	1251-2195	1	INSERT:R AND P CONNECTOR	71468	DM 53743-5001

See introduction to this section for ordering information

Table 6-3. Replaceable Parts

Reference Designation	HP Part Number	Qty	Description	Mfr Code	Mfr Part Number
W15	08553-60114	1	CABLE ASSY:A10J2 TO P4A4	28480	08553-60114
W15	1251-2193	1	CONNECTOR:RF SUB MINIATURE	28480	1251-2193
W16	08553-60117	1	CABLE ASSY:P4A7 TO R1	28480	08553-60111
W16	1251-2199	1	HOOD:R AND P CONNECTOR SERIES D	71468	DD51217-1
W17	08553-60141	1	CABLE ASSY:3 MHZ, IF(P4A5 TO J3-23)	28480	08553-60141
XF1	1400-0008	1	FUSEHOLDER:BRONZE CLIP FOR #6 SCREW MISCELLANEOUS	75915	3510-11
	1460-0199	1	SPRING:EXTENSION	28480	1460-0199
	2190-0057		WASHER:LOCK FOR #12 HDW	00000	OBD
	1121-0109	1	NAMEPLATE	28480	1121-0109
	8160-0035	1	BRAID:WIRE SHIELDING MONEL 3/32 OD	12881	10-056
	0340-0039	2	INSULATOR:BUSHING	28480	0340-0039
	0360-0368	1	TERMINAL:SOLDER LUG FOR #12 SCREW	78189	2168-12-01
	0360-0452	6	TERMINAL:SOLDER LUG FOR #10 SCREW	79963	540
	0590-0159	13	NUT:HEX FOR 0160-3219 CAPACITOR	72982	2499-202
	0624-0078	62	SCREW:TAPPING 6-32 THREAD	00000	OBD
	0624-0097	2	SCREW:TAPPING 4-40 THREAD	00000	OBD
	0624-0205	4	SCREW:TAPPING 6-32 THREAD	00000	OBD
	0624-0206	3	SCREW:TAPPING 6-32 THREAD	00000	OBD
	0624-0211	4	SCREW:TAPPING 6-32 THREAD	00000	OBD
	0624-0212	4	SCREW:TAPPING 6-32 THREAD	00000	OBD
	0624-0233	2	SCREW:TAPPING 6-32 THREAD	00000	OBD
	0624-0240	2	SCREW:TAPPING 4-40 THREAD	00000	OBD
	0624-0255	2	SCREW:TAPPING 2-56 THREAD	00000	OBD

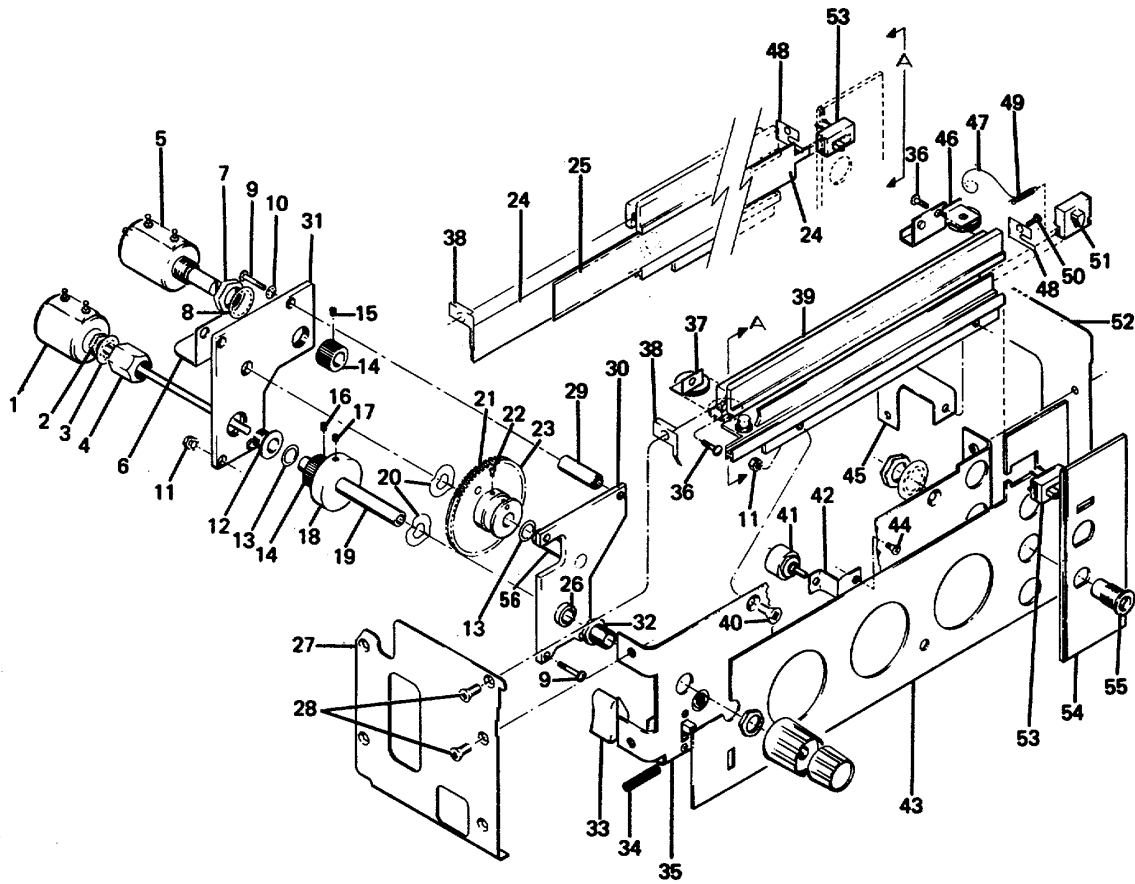

See introduction to this section for ordering information

Table 6-3. Replaceable Parts

Reference Designation	HP Part Number	Qty	Description	Mfr Code	Mfr Part Number
1	2100-2907	1	R:VAR CERMET 2K OHM 10% LIN 2W	28480	2100-2907
2	2950-006	1	NUT:HEX 1/4-32 THREAD	73734	9000
3	2190-0067	1	WASHER:LOCK FOR 1/4" HDW	28480	2190-0067
4	08553-2029	1	BUSHING:FINE TUNE POT	28480	08553-2029
5	2100-2528	1	R:VAR CERMET 5K OHM 10% LIN 2W	28480	2100-2528
6	08553-0033	1	BRACKET:IF CONNECTOR	28480	08553-0033
7	2950-0001	1	NUT:HEX BRS NP 3/8-32 X 1/2	73734	9002
8	2190-0016	1	WASHER:LOCK PH BRZ NP	00000	OBD
9	2360-133	1	SCREW:PAN HD POZI DR 6-32 X 1-1/4"	00000	OBD
10	2190-0007	1	WASHER:INT LOCK #6	28480	2190-0007
11	2420-0001	1	NUT:HEX ST NP 6-32 X 5/16 W/LOCKWASHER	78189	OBD#
12	08553-2028	1	BUSHING:TUNING SHAFT	28480	08593-2028
13	3050-0017	1	WASHER:FLAT PHOS BRONZE	00000	OBD
14	08553-2039	2	SPUR GEAR: 29T	28480	08553-2039
15	2030-0145	1	SCREW:SET 6-32 X 3/16"	00000	OBD
16	3030-0342	1	SCREW:SET 6-32 X 5/32" LG	00000	OBD
17	3030-0007	1	SCREW:SET SST 4-40 X 1/8"	00000	OBD
18	08553-2020	1	FLYWHEEL	28480	08553-2020
19	08553-2021	1	SHAFT:MAIN TUNING	28480	08553-2021
20	5000-0206	1	SPRING:WASHER	28480	5000-0206
21	08553-2040	1	SPUR GEAR, 112T	28480	08553-2040
22	0520-0127	1	SCREW:PAN HD POZI DR 2-56 X 3/16"	00000	OBD
23	08553-6034	1	GEAR AND HUB ASSY	28480	08553-2034
24	08553-40103	1	WINDOW SLIDING-BLACK	28480	08553-40103
24	08553-40106	1	WINDOW:SLIDING-OLIVE BLACK	28480	08553-40106
25	08553-40102	1	WINDOW:STATIONARY-BLACK	28480	08553-40102
25	08553-40105	1	WINDOW:STATIONARY-OLIVE BLACK	28480	08553-40105
26	1410-0088	1	BUSHING:1/4 DIA	71041	B46-2
27	08553-0001	1	FRAME:LEFT	28480	08553-0007
28	2360-0193	2	SCREW:PAN HD POZI DR 6-32 X 1/4"	00000	OBD
29	08553-2022	4	SPACER:GEARBOX	28480	08553-2022
30	08553-2018	1	PLATE:FRONT	28480	08553-2018
31	08553-2019	1	PLATE:REAR	28480	08553-2019
32	08553-2016	1	BUSHING:PANEL	28480	08553-2016
33	00197-47403	1	BUTTON:DETENT	28480	00197-47403
34	1460-0199	1	SPRING:EXTENSION	28480	1460-0199
35	08553-00105	1	PANEL:SUB	28480	08553-00105
36	2200-0103	1	SCREW:SST PHH POZI DR 4-40 X 1/4"W/LK	00000	OBD
37	08553-6029	1	PULLEY ASSY:LEFT	28480	08553-6029
38	08553-00113	1	SPRING:WINDOW	28480	08553-00113
39	08553-20114	1	EXTRUSION-LIGHT GRAY	28480	08553-20114
39	08553-20133	1	EXTRUSION-MINT GRAY	28480	08553-20133
40	2360-0200	1	SCREW:FLAT HD POZI DR 6-32 X 1/2"	00000	OBD
41	2100-2488	1	R:VAR COMP 10K OHM 20% LIN 1/2W	28480	2100-2488
42	08553-0009	1	BRACKET:POT	28480	08553-0009
43	08553-00106	1	PANEL:FRONT-LIGHT GRAY	28480	08553-00106
43	08553-00114	1	PANEL:FRONT-MINT GRAY	28480	08553-00114
44	2200-0165	1	SCREW:FLAT HD POZI DR 4-40 X 1/4"	00000	OBD
45	08553-0017	1	BRACKET:ATTENUATOR	28480	08553-0017
48	08553-6030	1	PULLEY ASSY:RIGHT	28480	08553-6030
47	8200-0049	1	DIAL CORD:DACRON	28480	8200-0049
48	08553-0016	1	SPRING:WINDOW	28480	08553-0016
49	1460-0195	1	SPRING:EXTENSION	28480	1460-0195
50	2360-0193	1	SCREW:PAN HD POZI DR 6-32 X 1/4"	00000	OBD
51	08553-4001	1	POINTER	28480	08553-4001
52	08553-0008	1	FRAME:RIGHT	28480	08553-0008
53	3101-0070	1	SWITCH:SLIDE	79727	G-126
54	08553-20113	1	PLATE:CONNECTOR-BLACK	28480	08553-20113
54	08553-00115	1	PLATE:CONNECTOR-OLIVE BLACK	28480	08553-00115
55	5060-0467	1	CONNECTOR:MALE PROBE	28480	5060-0467
56	5020-3349	1	SHAFT:SST	28480	5020-3349

See introduction to this section for ordering information

**PART NUMBER - NATIONAL STOCK NUMBER
CROSS REFERENCE INDEX**

PART NUMBER	FSCM	NATIONAL STOCK NUMBER	PART NUMBER	FSCM	NATIONAL STOCK NUMBER
0121-0048	28480	5910-00-683-7157	0160-2262	28480	5910-00-887-9754
0131-0004	28480	5910-00-818-6491	0160-2263	28480	5910-00-401-7891
0140-0069	28480	5910-00-892-9193	0160-2264	28480	5910-00-318-8758
0140-0193	28480	5910-00-774-7319	0160-2265	28480	5910-00-444-6725
0140-0197	28480	5910-00-544-6742	0160-2266	28480	5910-00-430-5754
0140-0198	28480	5910-00-914-2605	0160-2307	28480	5910-00-406-9675
0150-0050	28480	5910-00-784-0927	0160-2327	28480	5910-00-244-7171
0150-0073	28480	5910-00-739-7738	0160-2930	28480	5910-00-465-9754
0150-0093	28480	5910-00-542-2010	0160-3005	28480	5910-00-430-5812
0150-0121	28480	5910-00-950-6822	0160-3020	28480	5910-00-138-7336
0160-0157	28480	5910-00-961-9591	0160-3075	28480	5910-00-430-5816
0160-0161	28480	5910-00-911-9271	0160-3121	28480	5910-00-138-7268
0160-0163	28480	5910-00-893-1261	0160-3498	28480	5910-00-138-3415
0160-0303	28480	5910-00-430-5618	0170-0042	28480	5910-00-928-8229
0160-0337	28480	5910-00-776-4017	0170-0069	28480	5910-00-965-9722
0160-0419	28480	5910-00-728-1597	0180-0097	28480	5910-00-255-3738
0160-2139	28480	5910-00-180-7816	0180-0098	28480	5910-00-430-5947
0160-2140	28480	5910-00-430-5625	0180-0116	28480	5910-00-809-4701
0160-2143	28480	5910-00-430-5628	0180-0137	28480	5910-00-915-1393
0160-2145	28480	5910-00-430-5637	0180-0197	28480	5910-00-850-5355
0160-2199	28480	5910-00-244-7164	0180-0228	28480	5910-00-719-9907
0160-2204	28480	5910-00-463-5949	0180-0269	28480	5910-00-043-1396
0160-2205	28480	5910-00-430-5674	0180-0291	28480	5910-00-931-7055
0160-2208	28480	5910-00-430-5685	0180-1743	28480	5910-00-430-6017
0160-2215	28480	5910-00-430-5693	0180-2214	28480	5910-00-009-3200
0160-2222	28480	5910-00-244-7170	0340-0008	28480	6625-00-020-9870
0160-2227	28480	5910-00-430-5696	0340-0039	28480	5970-00-072-1625
0160-2255	28480	5910-00-430-5934	0360-0124	28480	5940-00-993-9338
0160-2256	28480	5910-00-009-3197	0370-0102	28480	5355-00-906-8933
0160-2260	28480	5910-00-789-6956	0370-0114	28480	5355-00-908-9418
0160-2261	28480	5910-00-430-5750	0370-0116	28480	5355-00-915-5010

**PART NUMBER - NATIONAL STOCK NUMBER
CROSS REFERENCE INDEX**

PART NUMBER	FSCM	NATIONAL STOCK NUMBER	PART NUMBER	FSCM	NATIONAL STOCK NUMBER
0410-0013	28480	5955-00-084-8503	0698-3443	28480	5905-00-194-0341
0410-0150	28480	5955-00-403-4249	0698-3444	28480	5905-00-974-6079
0490-0399	28480	5945-00-477-9296	0698-3449	28480	5905-00-828-0397
0698-0024	28480	5905-00-891-2808	0698-3450	28480	5905-00-826-3262
0698-0082	28480	5905-00-974-6075	0698-3460	28480	5905-00-826-2047
0698-0083	28480	5905-00-407-0052	0698-4037	28480	5905-00-232-3122
0698-0084	28480	5905-00-974-6073	0698-4190	28480	5905-00-126-1705
0698-3132	28480	5905-00-828-0388	0698-4521	28480	5905-00-489-2050
0698-3136	28480	5905-00-891-4247	0698-5192	28480	5905-00-477-9191
0698-3151	28480	5905-00-246-0634	0698-5194	28480	5905-00-477-9192
0698-3152	28480	5905-00-420-7130	0698-5196	28480	5905-00-477-9193
0698-3153	28480	5905-00-974-6081	0698-5401	28480	5905-00-412-4014
0698-3154	28480	5905-00-891-4215	0698-6299	28480	5905-00-477-9196
0698-3156	28480	5905-00-974-6084	0698-6300	28480	5905-00-477-9197
0698-3157	28480	5905-00-433-6904	0698-6302	28480	5905-00-477-9198
0698-3158	28480	5905-00-858-8927	0698-6315	28480	5905-00-477-9200
0698-3159	28480	5905-00-407-0053	0698-6668	28480	5905-00-477-9201
0698-3160	28480	5905-00-974-6078	0698-6669	28480	5905-00-452-1203
0698-3161	28480	5905-00-974-6082	0698-7188	28480	5905-00-138-7304
0698-3243	28480	5905-00-891-4227	0698-7212	28480	5905-00-138-7305
0698-3260	28480	5905-00-998-1809	0698-7532	28480	5905-00-138-3399
0698-3271	28480	5905-00-407-0054	0698-7533	28480	5905-00-138-3400
0698-3378	28480	5905-00-856-9865	0757-0123	28480	5905-00-954-8648
0698-3433	28480	5905-00-407-0076	0757-0158	28480	5905-00-430-6204
0698-3434	28480	5905-00-997-4071	0757-0199	28480	5905-00-981-7513
0698-3435	28480	5905-00-489-2046	0757-0278	28480	5905-00-110-0851
0698-3437	28480	5905-00-402-7080	0757-0279	28480	5905-00-221-8310
0698-3438	28480	5905-00-974-6080	0757-0280	28480	5905-00-853-8190
0698-3439	28480	5905-00-407-0059	0757-0288	28480	5905-00-193-4318
0698-3441	28480	5905-00-974-6076	0757-0289	28480	5905-00-998-1908
0698-3442	28480	5905-00-489-6773	0757-0290	28480	5905-00-858-8826

**PART NUMBER - NATIONAL STOCK NUMBER
CROSS REFERENCE INDEX**

PART NUMBER	FSCM	NATIONAL STOCK NUMBER	PART NUMBER	FSCM	NATIONAL STOCK NUMBER
0757-0317	28480	5905-00-244-7189	0757-0819	28480	5905-00-430-6215
0757-0346	28480	5905-00-998-1906	0757-0839	28480	5905-00-931-9909
0757-0394	28480	5905-00-412-4036	0764-0044	28480	5905-00-982-8694
0757-0398	28480	5905-00-788-0291	08552-6018	28480	5950-00-430-6816
0757-0400	28480	5905-00-998-1902	08552-6024	28480	5950-00-138-1334
0757-0401	28480	5905-00-981-7529	08553-6002	28480	6625-00-413-5921
0757-0403	28480	5905-00-412-4023	08553-6003	28480	6625-00-004-1207
0757-0416	28480	5905-00-990-1795	08553-6004	28480	6625-00-003-3646
0757-0417	28480	5905-00-850-9137	08553-6006	28480	5915-00-431-3157
0757-0418	28480	5905-00-412-4037	08553-6007	28480	6625-00-003-3644
0757-0419	28480	5905-00-891-4213	08553-6008	28480	6625-00-411-9656
0757-0421	28480	5905-00-891-4219	08553-6010	28480	6625-00-003-3645
0757-0422	28480	5905-00-728-9980	08553-6012	28480	5950-00-138-1335
0757-0424	28480	5905-00-493-0736	08553-60122	28480	6625-00-414-7776
0757-0428	28480	5905-00-998-1794	08553-60123	28480	6625-00-140-5036
0757-0438	28480	5950-00-929-2529	08553-6013	28480	5950-00-431-3176
0757-0439	28480	5905-00-990-0303	08553-6014	28480	5950-00-431-3118
0757-0440	28480	5905-00-858-6795	08553-6015	28480	5950-00-431-3179
0757-0441	28480	5905-00-858-6799	08553-6016	28480	5950-00-431-3176
0757-0442	28480	5905-000990-1792	08553-6019	28480	5950-00-431-3102
0757-0444	28480	5905-00-858-9132	08553-6036	28480	6625-00-422-3575
0757-0453	28480	5905-00-193-4298	08553-6057	28480	6625-00-003-3644
0757-0458	28480	5905-00-493-4628	08553-6063	28480	5910-00-430-6120
0757-0460	28480	5905-00-858-8959	08553-8001	28480	5961-00-412-0949
0757-0465	28480	5905-00-904-4412	1200-0063	28480	5999-00-937-4420
0757-0466	28480	5905-00-118-7906	1200-0173	28480	5999 00-008-7037
0757-0467	28480	5905-00-858-8959	1250-0118	28480	5935-00-897-9351
0757-0802	28480	5905-00-430-6211	1250-0252	28480	5935-00-059-1126
0757-0814	28480	5905-00-255-3750	1250-0826	28480	5935-00-934-2552
0757-0815	28480	5905-00-222-6276	1250-0830	28480	5935-00-488-9782
0757-0816	28480	5905-00-974-6219	1250-0888	28480	5935-00-450-0102

**PART NUMBER - NATIONAL STOCK NUMBER
CROSS REFERENCE INDEX**

PART NUMBER	FSCM	NATIONAL STOCK NUMBER	PART NUMBER	FSCM	NATIONAL STOCK NUMBER
1250-0930	28480	5935-00-138-5123	1901-0347	28480	5961-00-927-5507
1250-1006	28480	5935-00-138-5122-	1901-0441	28480	5961-00-412-0954
1251-0055	28480	5935-00-623-7199	1901-0450	28480	5961-00-937-7022
1251-0135	28480	5935-00-972-9464	1902-0057	28480	5961-00-774-7313
1251-2193	28480	5935-00-246-1743	1902-0518	28480	5961-00-138-7317
1251-2195	28480	5999-00-977-6240	1902-0785	28480	5961-00-891-4244
1251-2199	28480	5935-00-948-2792	1902-3025	28480	5961-00-138-7318
1400-0008	28480	5920-00-804-9600	1902-3036	28480	5961-00-350-2205
1410-0088	28480	3120-00-287-9026	1902-3049	28480	5961-00-412-0956
1450-0153	28480	6250-01-082-7506	1902-3304	28480	5961-00-995-2310
1450-0371	28480	6210-00-834-2578	1902-3345	28480	5961-00-412-0956
1853-0020	28480	5961-00-904-2540	1910-0016	28480	5961-00-995-9182
1853-0034	28480	5961-00-987-4700	2100-0942	28480	5905-00-929-3069
1854-0009	28480	5961-00-853-7941	2100-1657	28480	5905-00-138-3409
1854-0019	28480	5961-00-919-4566	2100-1758	28480	5905-00-220-5909
1854-0022	28480	5961-00-917-0660	2100-1761	28480	5905-00-407-0067
1854-0035	28480	5961-00-976-2857	2100-1762	28480	5905-00-229-1972
1854-0042	28480	5961-00-931-7000	2100-1772	28480	5905-00-891-4221
1854-0071	28480	5961-00-137-4608	2110-1910	28480	5905-00-489-8323
1854-0221	28480	5961-00-836-1887	2100-2488	2840B	5905-00-407-0068
1854-0233	28480	5961-00-227-9783	2100-2528	28480	5905-00-138-5087
1854-0247	28480	5961-00-464-4049	2100-2907	28480	5905-00-138-5088
1854-0345	28480	5960-00-401-0507	2140-0259	28480	6240-00-103-0058
1854-0435	28480	5961-00-138-5084	2190-0016	28480	5310-00-401-6931
1855-0049	28480	5960-00-520-5000	2200-0103	28480	5305-00-492-8796
1855-0098	28480	5961-00-030-6818	2360-0193	28480	5305-00-587-7642
1901-0025	28480	5961-00-978-7468	2420-0001	28480	5310-00-687-7337
1901-0039	28480	5961-00-833-6626	2950-0001	28480	5310-00-450-3324
1901-0040	28480	5961-00-965-5917	3030-0007	28480	5305-00-803-1545
1901-0047	28480	5960-00-929-7778	3100-2657	28480	5930-00-199-6835
1901-0049	28480	5961-00-911-9275	3100-2658	28480	5930-00-199-6036

**PART NUMBER - NATIONAL STOCK NUMBER
CROSS REFERENCE INDEX**

PART NUMBER	FSCM	NATIONAL STOCK NUMBER	PART NUMBER	FSCM	NATIONAL STOCK NUMBER
3101-0070	28480	5930-00-919-1755			
3101-1338	28480	5930-00-412-0938			
3101-1560	28480	5930-00-767-2442			
5020-0176	28480	5970-00-531-7134			
5060-0467	28480	5935-00-180-4186			
5080-0271	28480	5960-00-513-2726			
5082-2800	28480	5960-00-252-1309			
9100-1611	28480	5950-00-438-4375			
9100-1618	28480	5950-00-431-3196			
9100-1656	28480	5950-00-431-3206			
9100-3665	28480	5950-00-430-6878			
9100-1698	28480	5950-00-430-6881			
9100-2249	28480	5950-00-430-6882			
9100-2250	28480	5950-00-138-1356			
9100-2252	28480	5950-00-430-6904			
9100-2817	28480	5950-00-412-4341			
9140-0096	28480	5950-00-138-1381			
9140-0114	28480	5950-00-657-8167			
9140-0129	28480	5950-00-845-6927			
9140-0141	28480	5950-00-059-5919			
9140-0158	28480	5950-00-059-5920			

SECTION VII MANUAL CHANGES

7-1. INTRODUCTION

7-2. As changes are made to the 8553B, newer instruments may have serial number prefixes not listed in this manual. The manuals for those instruments will be supplied with an additional "Manual Changes" insert containing the required information; contact your local Hewlett-Packard Sales and Service Office if this sheet is missing.

7-3. The information in this section covers the manual changes necessary to:

a. Convert this manual so that it directly applies to the 8553B Option H01/H02 75-ohm RF Section (see paragraph 7-4).

b. Back-date this manual so that it directly applies to 8553B RF Sections with serial numbers 0982A00975 and below (see paragraph 7-12).

7-4. 8553B OPTION H01/H02

7-5. The 75-ohm RF section differs from the 50-ohm RF section only in the input circuitry. Matching pads are added to change the input impedance to 75 ohms. These circuit changes are shown here with partial schematics that can be copied and added directly to Service Sheets 3 and 4 in Section VIII (see Figures 7-4 and 7-5). Changes to the parts list are shown in Table 7-1.

7-6. The input impedance change also affects the specifications (see Table 1-1) and the performance tests. Paragraph 7-8 shows the changes to paragraph 4-23. Paragraph 7-9 replaces paragraph 4-27, paragraph 7-10 replaces paragraph 4-28, and paragraph 7-11 replaces paragraph 4-29.

PERFORMANCE TESTS

7-7. PERFORMANCE TEST PROCEDURE CHANGES FOR OPTION H01/H02

7-8. Input Impedance

SPECIFICATION: Change to Input Impedance: 75-ohm nominal. Reflection Coefficient ≤ 0.13 (≤ 1.30 SWR).

Step 2. Change impedance limits to: 57.7 _____ 97.5 ohms

Step 6. Change voltmeter reading limits to: 16 _____ 19.8 mV

Step 8. Change to read: Repeat steps 1-7 with INPUT ATTENUATOR set to 20 dB, 10 dB and finally, 0 dB.

7-9. Average Noise Level

SPECIFICATION:

IF Bandwidth (kHz)	Avg. Noise Level (dBm)	Frequency Range (MHz)
1	-110	1 - 110
10	-100	1 - 110
100	-90	1 - 110

DESCRIPTION:

Sensitivity is checked by measuring the average noise power level of the analyzer with the instrument vertically calibrated. The test is made using IF bandwidths listed in the specification.

PERFORMANCE TESTS (cont'd)

7-9. Average Noise Level (cont'd)

1. Check the analyzer to make sure it is vertically calibrated. Refer to Paragraph 4-12 for instructions. In Paragraph 4-20a, change to read: Set the LOG/LINEAR switch to LINEAR. Set LINEAR SENSITIVITY to 2 mV/div (2 mV x 1). Since the -30 dBm calibrator output is 8.66 mV (across 75 ohms), the CRT deflection should be -4.33 divisions.
2. Make the following analyzer control settings:

RANGE MHz 0-110
 FREQUENCY 30 MHz
 BANDWIDTH 1 kHz
 SCAN WIDTH ZERO
 INPUT ATTENUATION 0 dB
 BASE LINE CLIPPER CCW
 SCAN TIME PER DIVISION 50 MILLISECONDS
 LOG REF LEVEL -50 dBm
 LOG REF LEVEL vernier 0
 LOG-LINEAR LOG
 VIDEO FILTER 100 Hz
 SCAN MODE INT
 SCAN TRIGGER AUTO

3. Observe the average noise power level on the CRT. It should be lower than -110 dBm as shown in Figure 7-1. Make sure the LOG REF LEVEL vernier is set at 0 during the measurement.

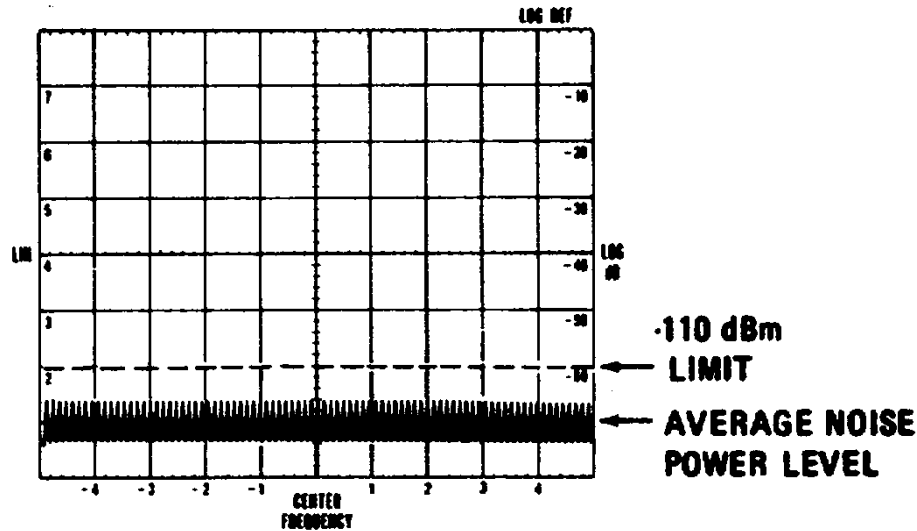

Figure 7-1. Sensitivity Measurement: CRT Display.

4. Set BANDWIDTH to 10 kHz, and repeat step 3. The average noise power level should be lower than -100 dBm. _____ -100 dBm
5. Set BANDWIDTH to 100 kHz, and repeat step 3. The average noise power level should be lower than -90 dBm. _____ -90 dBm

PERFORMANCE TESTS (cont'd)

7-10. Spurious Responses

SPECIFICATION: Spurious Responses: For -30 dBm signal level to the input mixer* : image responses, out-of-band mixing responses, harmonics and intermodulation distortion products, and IF feedthrough responses all more than 70 dB below the input signal level (2 MHz to 110 MHz); 60 dB, 1 kHz to 2 MHz.

Third Order Intermodulation Products: For -30 dBm signal level at input mixer*, more than 70 dB down for input signals of 100 kHz to 110 MHz.

*Signal level at input mixer = Signal level at RF INPUT (INPUT ATTENUATION + 10 dB)

DESCRIPTION: The outputs of two signal generators tuned within 50 kHz of one another are applied to the spectrum analyzer RF input. Their levels are adjusted (-33 dBm each) to -30 dBm total power at the analyzer input mixer. No responses other than the signals from the signal generators and the spectrum analyzer's 1st LO feedthrough (at zero frequency) should be present on the CRT within 70 dB of these signal levels. This corresponds to a level of -100 dBm.

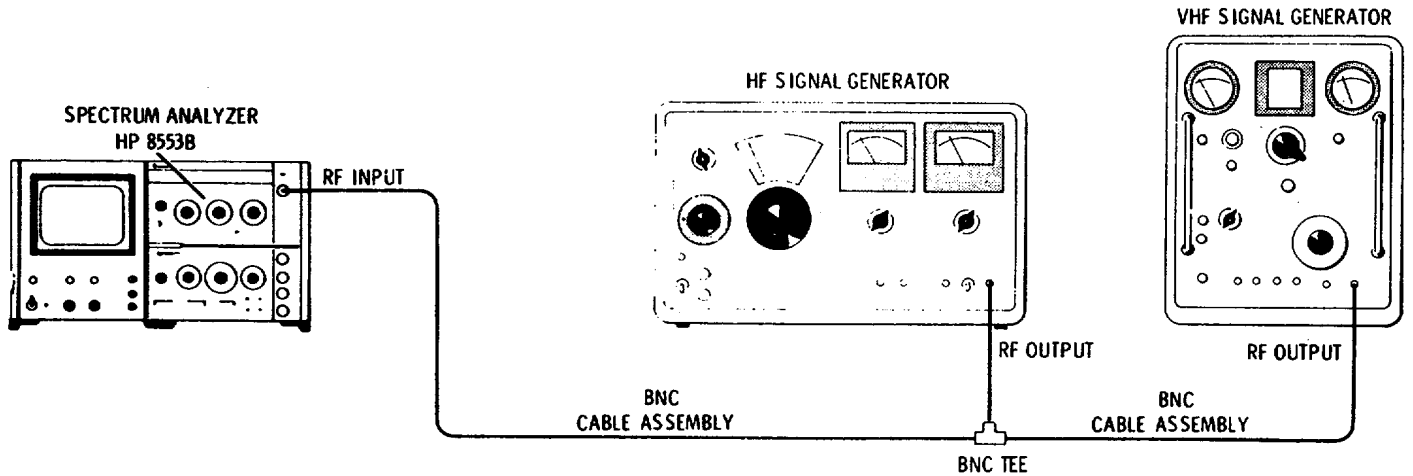

Figure 7-2. Intermodulation Distortion Test.

EQUIPMENT:

Signal Generator.....	HP 606B
Signal Generator.....	HP 608F
Cable Assembly (2).....	HP 10503A
BNC Tee.....	UG-274B/U

1. Connect the test setup shown in Figure 7-2 and make the following control settings:

Analyzer:

RANGE- MHz.....	0 - 110
BANDWIDTH.....	1 kHz
SCAN WIDTH.....	20 kHz/div
FREQUENCY.....	(see procedure)
INPUT ATTENUATION.....	dBm
SCAN TIME PER DIVISION.....	2 MILLISECONDS
LOG REF LEVEL.....	-30 dBm
TUNING STABILIZER.....	ON
VIDEO FILTER.....	OFF
SCAN MODE.....	INT
SCAN TRIGGER.....	AUTO

PERFORMANCE TESTS (cont'd)

7-10. Spurious Responses (cont'd)

Signal Generators

Signal Generator No 1 (606B) FREQUENCY 9 950 MHz
 Signal Generator No 2 (608F) FREQUENCY 10 MHz
 AMPLITUDE -30 dBm

2. Adjust the signal generator output attenuators and verniers so the signal amplitude reaches 3 dB below the top graticule line. Use as much attenuation as possible to reduce intermodulation distortion caused by signal generator interaction prior to application to the mixer.
3. Combine the signals as shown in Figure 4-12 and apply them to the analyzer.
4. Tune the analyzer to 50 kHz and check' for a second-order intermodulation product. Another second-order product will appear at 19.950 MHz.

50 kHz _____ -100 dBm
 19.950 MHz _____ -100 dBm

5. Tune the analyzer to 10.050 MHz and check for third-order IM. Third-order products also occur at the following frequencies: 9.900 MHz, 29.950 MHz, 29.900 MHz.

10.050 MHz _____ -100 dBm

NOTE

Signal generators exhibit harmonic distortion, typically about 35 dB below fundamental level. Harmonic distortion will occur at multiples of 9.950 and 10 MHz. Care must be taken not to confuse harmonic distortion produced by the source with intermodulation distortion produced by the input mixer.

7-11. Residual Responses

SPECIFICATION: (Referred to signal level at input mixer*)

200 kHz to 110 MHz: <-100 dBm
 20 kHz to 200 kHz: < --85 dBm

*Signal level at input mixer = Signal level at RF INPUT - (INPUT ATTENUATION +10 dB).

DESCRIPTION:

Signals present on the display with no input are called residual responses. To measure residual responses, select a reference so that -100 dBm is easily determined. Carefully search the display for residual responses under the various test conditions called out.

1. Set the analyzer controls as follows:

RANGE MHz 0-110
 FREQUENCY 60 MHz
 FINE TUNE.....Centered
 BANDWIDTH 1 kHz
 INPUT ATTENUATION 0
 SCAN WIDTH PER DIVISION

PERFORMANCE TESTS (cont'd)

7-11. Residual Responses (cont'd)

SCAN WIDTH PER DIVISION 10 MHz
 BASE LINE CLIPPER.....max CCW
 SCAN TIME PER DIVISION 10 SECONDS
 LOG REF LEVEL controls.....-50dBm
 TUNING STABILIZER..... ON
 VIDEO FILTER..... OFF
 SCAN MODE.....INT
 SCAN TRIGGER AUTO

2. Terminate the RF INPUT jack in 75 ohms.
3. Observe the display as the analyzer scans from 10 to 110 MHz. The average noise level should be less than -100 dBm, and no, residual responses should occur. Figure 7-3 represents a scan with no residual responses, and with the average noise level indicated.

Residual Responses 10 - 110 MHz:
 <-100 dBm___

4. To check the analyzer from 1 MHz to 10 MHz, make the following control settings:
 FREQUENCY 5 MHz
 SCAN WIDTH PER DIVISION..... 1 MHz
 SCAN TIME PER DIVISION 2 SECONDS

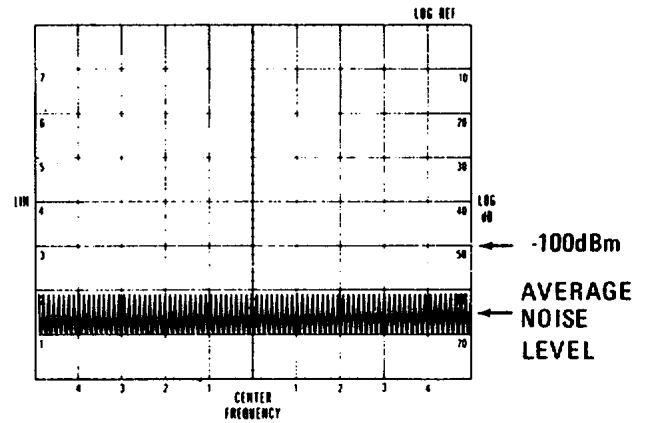

Figure 7-3. Residual Response Test: 10 to 110 MHz CRT-Display.

5. Observe the display for residual responses:

Residual Responses 1 - 10 MHz:
 <-100 dBm___

6. To check the analyzer from 200 kHz to 1 MHz, make the following control settings:
 FREQUENCY Local Oscillator signal appears at left hand edge of graticule
 SCAN WIDTH PER DIVISION..... 0.1 MHz
 BANDWIDTH..... 1 kHz
 SCAN TIME PER DIVISION..... 5 SECONDS

7. Observe the display for residual responses over the last 8 horizontal divisions:

Residual Responses 200 kHz - 1 MHz:
 <-100 dBm___

8. To check the analyzer from 20 to 200 kHz, make the following control settings:
 RANGE-MHz 0-11
 FREQUENCY Local Oscillator signal appears at left hand of graticule
 SCAN WIDTH PER DIVISION..... 20 kHz
 BANDWIDTH..... 0.1 kHz
 SCAN TIME PER DIVISION..... 5 SECONDS
 LOG REF LEVEL..... -40 dBm

9. Observe the display for residual responses over the last nine horizontal divisions:

Residual Responses 20 - 200 kHz:
 <-85 dBm___

Table 7-1. H01/H02 Changes to Replaceable Parts, Table 6-3

Change to read as follows:

A9	08553-62007	200 MHz IF ASSY
A9A2	08553-62006	FIRST CONVERTER ASSY
A12	08553-62001	CAPACITOR ASSY (H01 ONLY)
W1	08553-62002	CABLE ASSY:75 OHM (H01)
W1	08663-62009	CABLE ASSY:75 OHM (H02)
54	08553-02006	PLATE:CONNECTOR-BLACK
54	08553-02008	PLATE:CONNECTOR-OLIVE BLACK

Add the following:

A9A2L1	9100-2251	COIL:FXD 0.22 UH 10%
A9A2R1	0698-3441	R:FXD 215 OHM 1% 1/8W
A9A2R2	0698-3432	R:FXD 26.1 OHM 1% 1/8W
A9A2R3	0698-3441	R:FXD 215 OHM 1% 1/8W
A15	08553-62003	MATCHING PAD ASSY
W18	08553-62004	CABLE ASSY:A3 TO A15
W18	1400-0025	CLAMP:CABLE
W18	08553-02002	BRACKET:CONNECTOR

7-12. MANUAL BACK-DATING

dating changes. Use Table 7-2 to find the changes needed to adapt this manual to your instrument. Then follow the instructions listed under the changes, performing the changes in sequence listed in Table 7-2.

7-13. Table 7-2 lists the serial number history of the 8553B and the manual back-dating changes needed to document any instrument. Table 7-3 lists the back-

Table 7-2. Back-Dating Serial Numbers

Serial Number or Prefix	Make Manual Changes (in sequence)
945-, 972-	E, D, C, B, A
982-00451 to 982-00525	E, D, C, B, A
982-00526 to 982-00950	E, D, C, B
982-00951 to 0982A00975	E, D, C
0982A00976 to 0982A01500	E, D
0982A01501 to 0982A01600	E
1144A	E

Table 7-3. Back-Dating Changes (1 of 2)

CHANGE A

On Table 6-2, Replaceable Parts:

Change as follows: A6A1R6 to 0757-0401	R:FXD 100 OHM
A7A1R19 to 0698-3429	R:FXD 19.6 OHM
A8A1R11 to 0698-3157	R:FXD 19.6K OHM
A9A1L11 to 9100-1611	COIL:FXD 0.22 UH
A10A1R5 to 0698-3431	R:FXD 23.7 OHM

CHANGE B

On Table 6-3, Replaceable Parts:

Change A2R19 to 0698-7534 R:FXD 22 OHM.

CHANGE C

Add the following notation to Table 6-3, Replaceable Parts:

When ordering replacement spring (08553-00113) for the sliding window on the front panel, order replacement stationary window (08553-40102). (The new spring is not compatible with the window on serial numbers 0982A00975 and below.)

Table 7-3. Back-Dating Changes (2 of 2)

CHANGE D

On Table 6-3, Replaceable Parts:

Change W1 to read as follows:

W1	08553-6062	CABLE ASSY:RF INPUT
W1	1260-1164	BODY:RF CONNECTOR SUB MIN
W1	1250-1169	NUT:RF CONNECTOR SUB MIN
W1	1250-1172	CONTACT:RF CONNECTOR SUB MIN
W1	1250-1173	INSULATOR:RF CONNECTOR SUB MIN

Add the following notation:

On instruments with serial number 0982A01600 and below, when either cable W1 or assembly A12 need replacing, it is necessary to replace both.

CHANGE E

On Table 6-3, Replaceable Parts:

Delete W17.

On Figure 8-18:

Delete "3 MHz IF, GRAY" from P4 illustration.

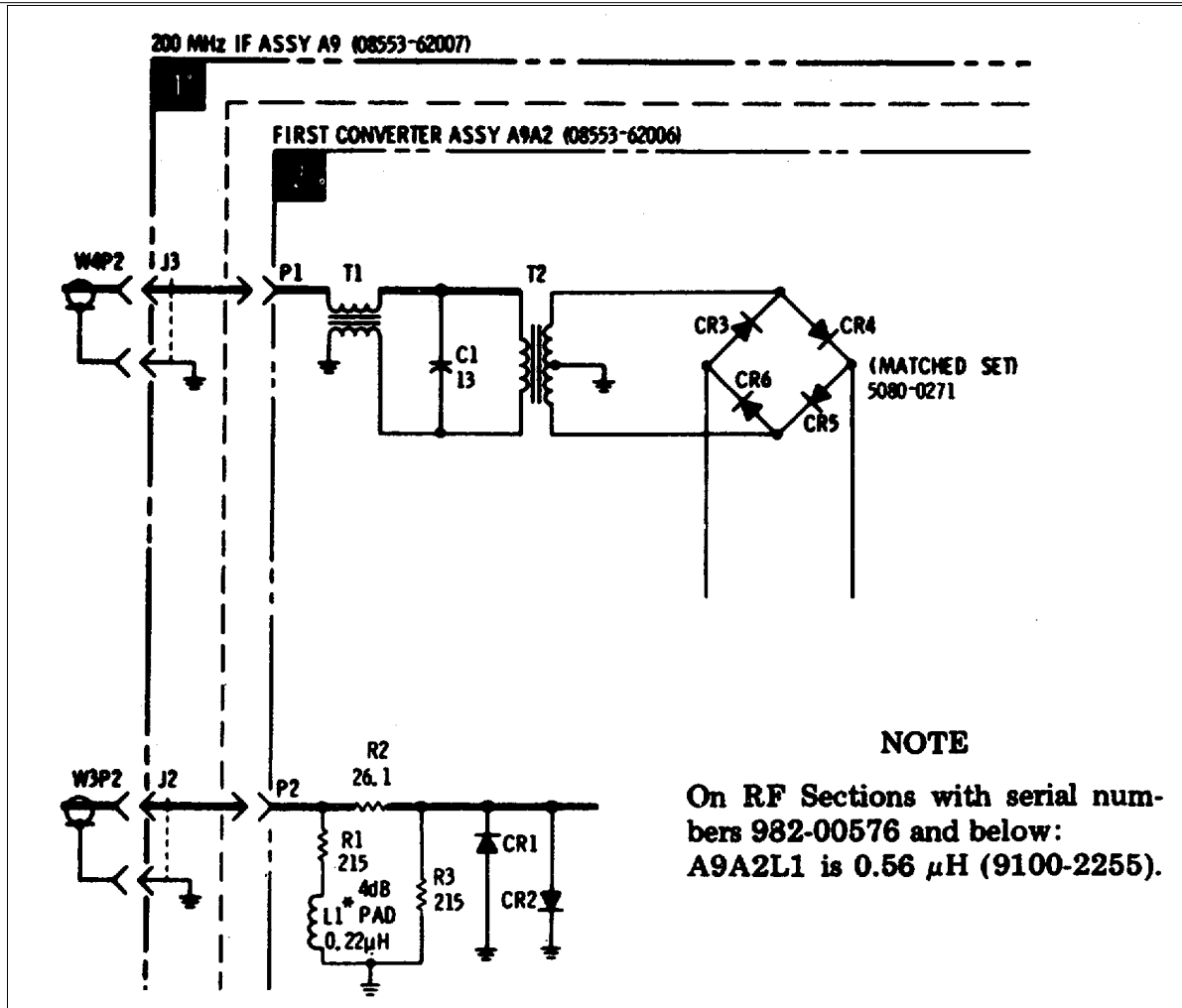

Figure 7-4. H01/H02 Schematic Changes for Service Sheet 4, Figure 8-31.

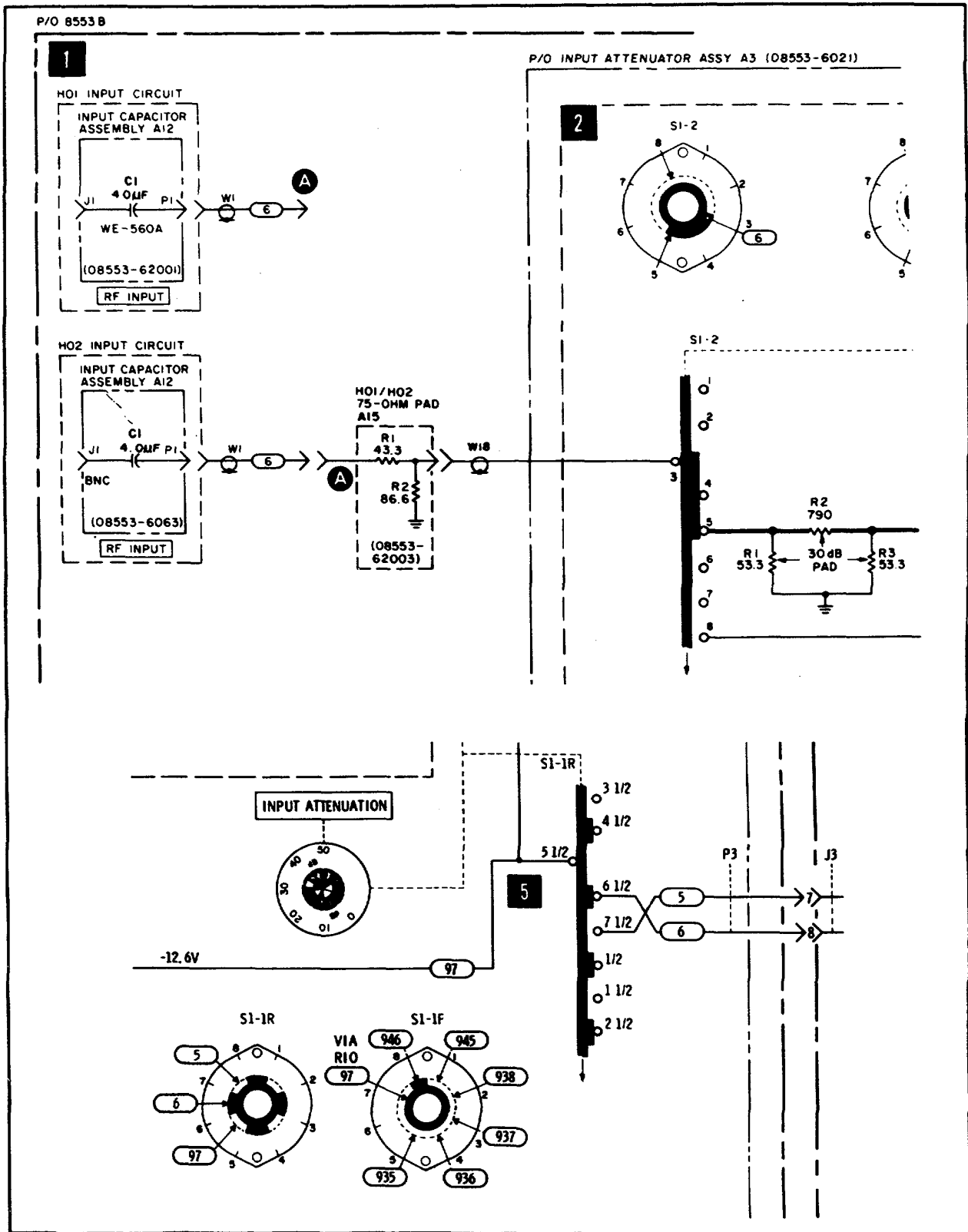

Figure 7-5. H01/H02 Schematic Changes for Service Sheet 3, Figure 8-26.

SECTION VIII

SERVICE

8-1. INTRODUCTION

8-2. This section provides instructions for troubleshooting and repair of the HP 8553B Spectrum Analyzer RF Section.

8-3. LINE VOLTAGE REQUIREMENTS

8-4. During adjustment and testing, the Spectrum Analyzer must be connected to a source of power which is 50 to 60 Hz and 115 or 230 Vac +10%. If adjustment of the dc voltage regulators is necessary, the Spectrum Analyzer should be connected to the ac power source

through a variable auto transformer. The line voltage to the Spectrum Analyzer may then be adjusted to check regulator action when the line voltage varies as much as 10%.

8-5. MAINTENANCE AIDS**8-6. Servicing Aids on Printed Circuit Boards .**

Servicing aids provided on circuit boards include holes to fit the board removal tool, numbered test points (on some boards), transistor designators, adjustment callouts, and assembly stock numbers.

Table 8-1. Test Equipment and Accessories List

Item	Critical Specifications	Model Number
Variable Voltage Transformer	Range: 103-127 Vac Voltmeter Range: 103-127 Vac \pm 1 volt	General Radio W5MT3A or Superior Electric UC1M
Tuneable RF Voltmeter	Bandwidth: 1 kHz; Frequency Range: 1-310 MHz; Sensitivity: 10 mV to 1V rms; Input Impedance \geq 0.1 megohms	HP 8405A Vector Voltmeter
Ohmmeter	Resistance Ranges: 1 ohm to 100 megohms Accuracy: \pm 10% of reading	HP 410C Volt-ohm- Ammeter
HF Signal Generator	Frequency Range: 1-50 MHz; Output Amplitude: -20 dBm; Output Amplitude Accuracy: \pm 1%; Freq. Accuracy: \pm 1%; Output Impedance: 50 ohms	HP 606B HF Signal Generator
VHF Signal	Frequency Range: 10 -310 MHz; Frequency Accuracy: \pm 1%; Output Amplitude > -20 dBm Output Impedance: 50 ohms	HP 608F VHF Signal Generator
Oscilloscope	Frequency Range: dc to 50 MHz; Time Base: 1 μ s/Div to 10 ms/Div; Time Base Accuracy: \pm 3%; Dual Channel, Alternate Operation, ac or dc coupling; External Sweep Mode; Voltage Accuracy Sensitivity: 0.005V/Div	HP 180A with HP 1801A Vertical Amplifier, and HP 1821A Horizontal Amplifier
Digital Voltmeter	Voltage Accuracy: \pm 0.2%; Voltage Range: 1-50 Vdc full scale; Input Impedance: 10 megohms	HP 3440A Digital Voltmeter with HP 3443A Plug-in
Frequency Counter	Frequency Range: 3-310 MHz; Accuracy: \pm 0.001%; Sensitivity: 100 mV rms; Readout Digits: \geq 7 digits	HP 5245L Frequency Counter with HP 5252A Plug-in
Service Kit	Devices required to service the Analyzer	HP 11592A
50-ohm Tee	Type N female connectors on two ports, with the third port able to accept HP 8405 probe.	HP 11536A 50-ohm Tee
BNC Tee	Two BNC Female Connectors, One Male BNC Connector.	UG-274 B/U, HP 1250-0781

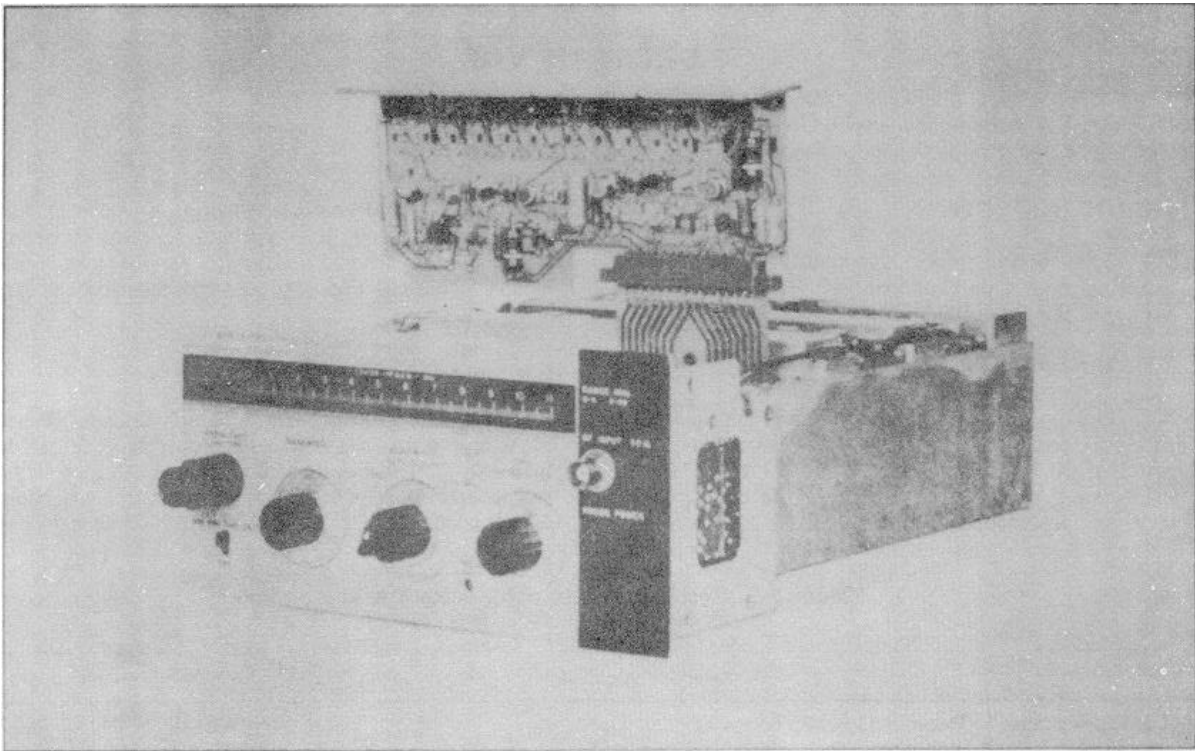

Figure 8-1. 8553B A5 Voltage Control Assy Extended for Maintenance.

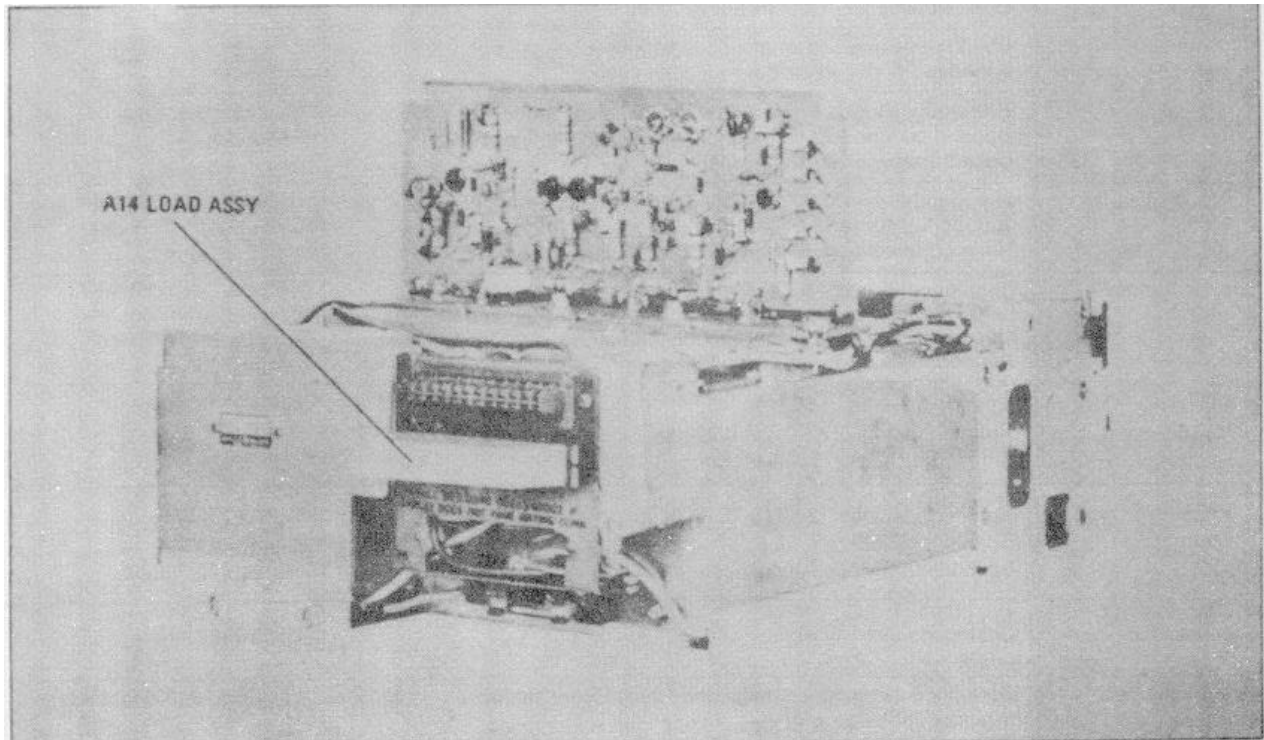

Figure 8-2. 8553B Inverted Extension for Maintenance.

8-7. TEST EQUIPMENT AND ACCESSORIES REQUIRED

8-8. Test equipment and accessory requirements are listed in the System Test and Troubleshooting Procedure, the individual Service Sheets, and in the test Equipments and Accessories list, Table 8-1. test instruments other than those listed may be used if their performance equals or exceeds that of the equipment listed.

8-9. Circuit Board Extender. A circuit board extender is supplied with the HP 11592A Service Kit. The extender board may be used to extend the A5 Voltage Control assembly in the 8553B, clear of the housing (see Figure 8-1) to provide easy access to test points and components. The rest of the assemblies in the 8553B may be removed and reinstalled in an inverted position by using the fasteners provided in the HP 11592A Service Kit (see Figure 8-2) to provide access to test points and components.

8-10. ADJUSTMENTS

8-11. The procedures contained in these sections do not include calibration or adjustment. Service Sheets which contain adjustable components refer procedures in the Performance and Adjustment sections which should be performed after repairs are accomplished.

8-12. GENERAL PROCEDURES

8-13. The troubleshooting procedure is divided into two maintenance levels. The first, System Test and Troubleshooting Procedure, is designed to quickly isolate the cause of a malfunction to a circuit or assembly. The second provides circuit analysis and test procedures to aid in isolating faults to a defective component. Circuit descriptions and test procedures for the second maintenance level are located on the page facing the schematic diagram of the circuit to be repaired.

8-14. After the cause of a malfunction has been located and remedied in any circuit containing adjustable components, the applicable procedure specified in the Performance and Adjustment action should be performed.

8-15. GENERAL SERVICE INFORMATION

8-16. Transistors and diodes are used throughout the Spectrum Analyzer in circuit configurations such as flip-flops, multivibrators, trigger circuits, switches, oscillators, and various types of amplifiers. Basic

transistor operation and some transistor circuits are shown in the following pages. Also included is basic information concerning the operation of Silicon Controlled Rectifiers, Zener Diodes, and Varactors.

8-17. Transistor In-Circuit Testing. The common causes of transistor failure are internal short circuits and open circuits. In transistor circuit testing, the most important consideration is the transistor base-to-emitter junction. The base emitter junction in a transistor is comparable to the control grid-cathode relationship in a vacuum tube. The base emitter junction is essentially a solid-state diode; for the transistor to conduct, this diode must be forward biased. As with simple diodes, the forward-bias polarity is determined by the materials forming the junction. Transistor symbols on schematic diagrams reveal the bias polarity required to forward-bias the base-emitter junction. The B part of Figure 8-3 shows transistor symbols with the terminals labeled. The other two columns compare the biasing required to cause conduction and cut-off in NPN and PNP transistors. If the transistor base-emitter junction is forward biased, the transistor conducts. However, if the base-emitter junction is reverse-biased, the transistor is cut off (open). The voltage drop across a forward-biased, emitter-base junction varies with transistor collector current. For example, forward-bias voltage for silicon transistors is about 0.5--0.6 volt when collector current is low, and about 0.8-0.9 volt when collector current is high.

8-18. Figure 8-3, Part A, shows simplified versions of the three basic transistor 'circuits and gives the characteristics of each. When examining a transistor stage, first determine if the emitter-base junction is biased for conduction (forward-biased) by measuring the voltage difference between emitter and base. When using an electronic voltmeter, do not measure directly between emitter and base; there may be sufficient loop current between the voltmeter leads to damage the transistor. Instead, measure each voltage separately with respect to a common point (e.g., chassis). If the emitter-base junction is forward-biased, check for amplifier action by short-circuiting base to emitter while observing collector voltage. The short circuit eliminates base-emitter bias and should cause the transistor to stop conducting (cut off). Collector voltage should then change and approach the supply voltage. Any difference is due to leakage current through the transistor and, in general, the smaller this current, the better the transistor. If the collector voltage does not change, the transistor has either an emitter-collector short circuit or emitter-base open circuit.

Table 8-2. Out-of-Circuit Transistor Testing.

Transistor Type		Connect Ohmmeter		Measure Resistance (ohms)
		Pos. lead to	Neg. lead to	
PNP Germanium	Small Signal	emitter	base*	200-250
		emitter	collector	10K-100K
	Power	emitter	base*	30-50
		emitter	collector	several hundred
PNP Silicon	Small Signal	emitter	base*	10K-100K
		emitter	collector	very high (might read open)
NPN Silicon	Small Signal	base	emitter	1K-3K
		collector	emitter	very high (might read open)
	Power	base	emitter	200-1000
		collector	emitter	high, often greater than 1M

*To test for transistor action, add collector-base short. Measured resistance should decrease.

Table 8-3. Ohmmeters Used for Transistor Testing.

Ohmmeter	Range(s)	Open Circuit Voltage	Short Circuit Voltage	Lead	
				Color	Polarity
HP 412A HP 427A	R x 1K	1.0V	1 mA	Red Black	+ -
	R x 10K	1.0V	100µA		
	R x 100K	1.0V	10µA		
	R x 1M	1.0V	1µA		
	R x 10M	1.0V	0.1µA		
HP 410C	R x 1K	1.3V	0.57mA	Red Black	+ -
	R x 10K	1.3V	57 µA		
	R x 100K	1.3V	5.7µA		
	R x 1M	1.3V	0.5µA		
	R x 10M	1.3V	0.05µA		
HP 410B	R x 100	1.1V	1.1 mA	Black Red	+ -
	R x 1K	1.1V	110µA		
	R x 10K	1.1V	11µA		
	R x 100K	1.1V	1.1µA		
	R x 1M	1.1V	0.11µA		
Simpson 260	R x 100	1.5V	1 mA	Red	+
Simpson 269	R x 1K	1.5V	0.82mA	Black Red	+ -
Triplet 630	R x 100	1.5V	3.25mA	Varies with Serial Number	
	R x 1K	1.5V	325µA		
Triplet 310	R x 10	1.5V	750 µA		
	R x 100	1.5V	75µA		

8-19. Transistor Out-of-Circuit Testing. Measuring the elements of a transistor will reveal the presence of internal shorts or open circuits. See Table 8-2 for measurement data and Figure 8-4 for examples of diode and transistor marking methods.

CAUTION

Most ohmmeters can supply enough current or voltage to damage a transistor. Before using an ohmmeter to measure transistor forward or reverse resistance, check its open-circuit voltage and short-circuit current output ON THE RANGE TO BE USED. Open-circuit voltage must not exceed 1.5 volts and short-circuit current must be less than 3 mA. See Table 8-3 for safe resistance ranges for some common ohmmeters.

8-20. Transistor Biasing and Conduction. In a transistor a small base-to-emitter current controls a

large collector-to-emitter current. Typical NPN transistor and PNP transistor operation is shown in Figure 8-3, part B; indicated current represents conventional flow of positive charges external to the transistor and is not intended to indicate flow of carriers inside the transistor structure. Notice that the effect of emitter-base-collector voltages is reversed between NPN and PNP transistors; circuits which are arranged for an NPN transistor usually function normally for a PNP transistor if supply voltages are reversed.

8-21. Transistor Amplifiers. There are three basic amplifier configurations (Figure 8-3, part A). These amplifiers may be used alone or in combination to form complex circuits.

8-22. BASIC TRANSISTOR CIRCUITS

8-23. Trigger Circuit. The trigger circuit (Figure 8-5, Schematic A) is a limiter or squaring circuit which

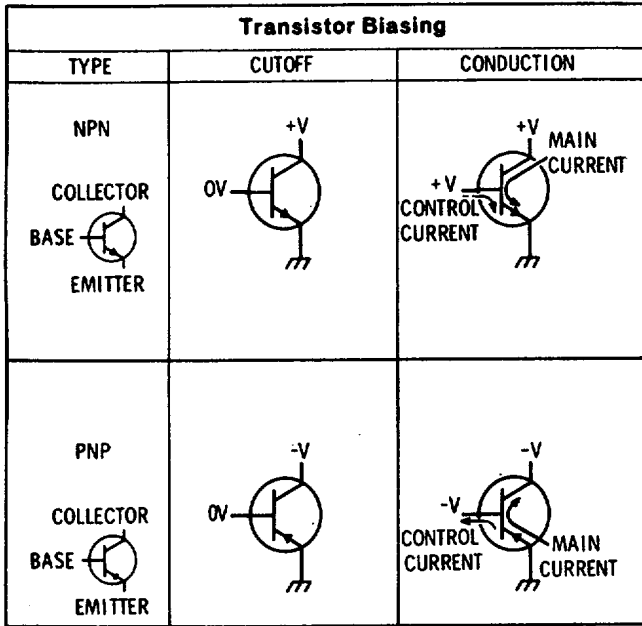

Amplifier Characteristics			
CHARACTERISTIC	COMMON BASE	COMMON EMITTER	COMMON COLLECTOR
Input Impedance	30Ω - 50Ω	500Ω - 1500Ω	20KΩ - 500KΩ
Output Impedance	300KΩ - 500KΩ	30KΩ - 50KΩ	50Ω - 1000Ω
Voltage Gain	500 - 1500	300 - 1000	< 1
Current Gain	< 1	25 - 50	25 - 50
Power Gain	20 dB - 30 dB	25 dB - 40 dB	10 dB - 20 dB (Emitter Follower)

Figure 8-3. Transistor Operation.

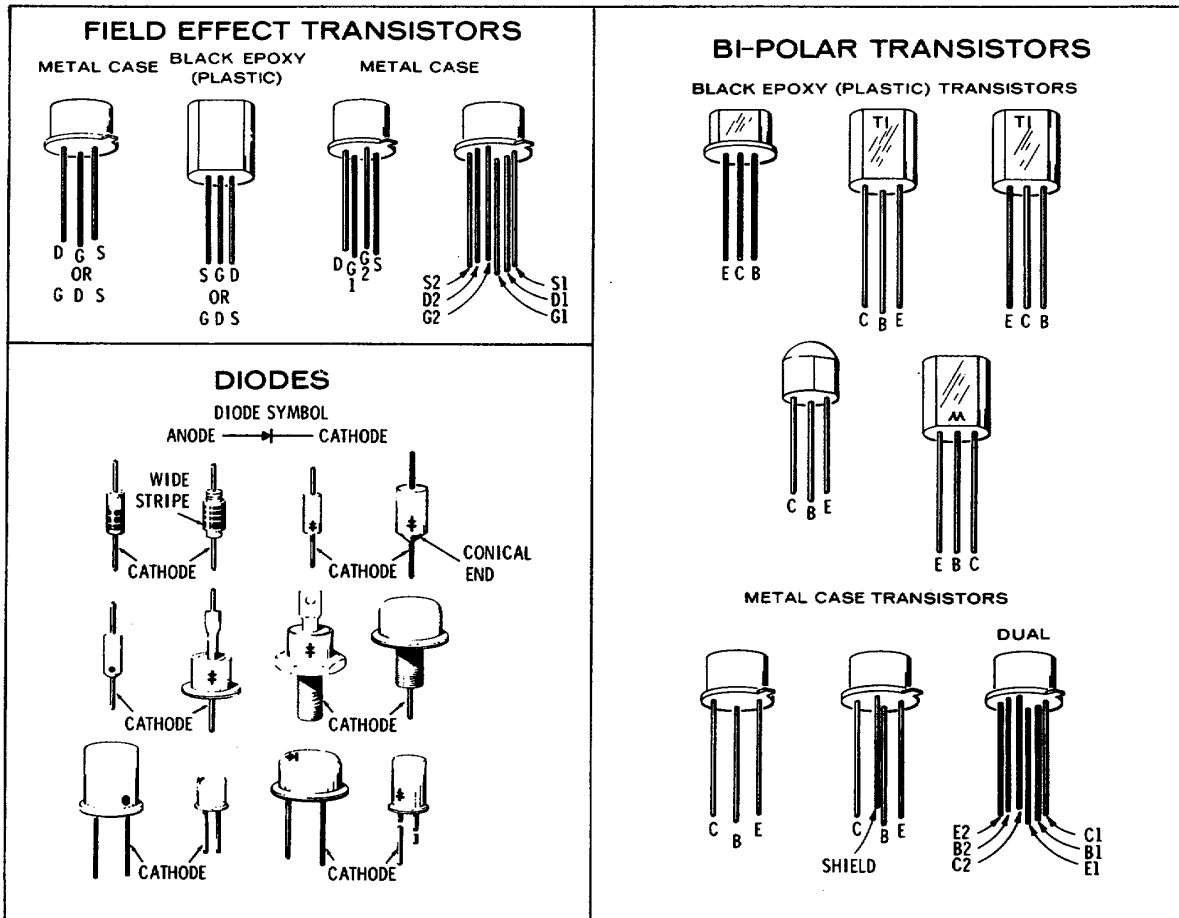

Figure 8-4. Examples of Diode and Transistor Marking Methods.

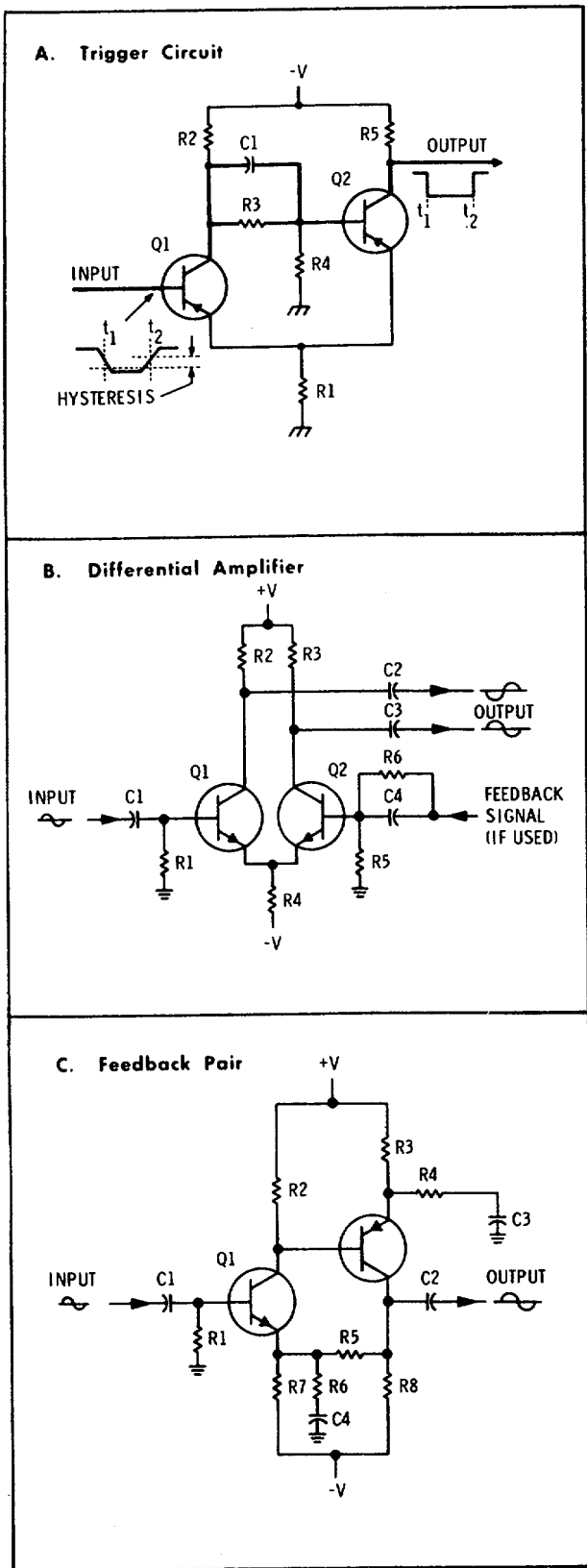

Figure 8-5. Basic Transistor Circuits.

times. The trigger circuit is similar to the flip-flop except that the RC network in one half is replaced by the input signal. Capacitor C1 bypasses R3 to couple fast changes in voltage at the Q1 collector to the base of Q2. Either Q1 or Q2 can conduct depending on the voltage at the input. Note that there is a slight difference in input voltage (called hysteresis) between switching with a negative-going input (time 1) and switching with a positive-going input (time 2).

8-24. Differential Amplifier. The differential amplifier (Figure 8-5, Schematic B) is composed of two transistor stages coupled together in the emitter circuit. Signals at the output of the two collectors are 180 degrees out-of-phase. Inverse feedback may be applied to the base of Q2 to control gain. As the voltage at the emitter of Q1 changes, the emitter of Q2 also changes by the same amount. This changes the base-to-emitter bias of Q2. If a more negative voltage were applied to the base of Q1, current through Q1 would decrease, causing the emitter of Q1 to go in the negative direction. A negative-going voltage at the emitter of Q2 increases the effective forward bias between base and emitter of Q2, causing it to conduct more heavily. Therefore, when current through Q1 decreases, current through Q2 increases.

8-25. Feedback-Pair Amplifier. The feedback-pair amplifier (Figure 8-5, Schematic C) is a high-gain direct-coupled amplifier stage composed of an NPN and a PNP transistor cascaded together. Feedback for the pair is accomplished by an RC network between the collector of Q2 and the emitter of Q1. Voltage gain of the stage may be calculated by the formula: $R5 + R6$ divided by $R6$, assuming $R7$ and $R8$ are much larger than $R5$ and $R6$. Gain of the amplifier may be controlled by changing the value of either $R5$ or $R6$.

8-26. Flip-Flop. The flip-flop is a bistable two-transistor circuit in which one transistor conducts, holding the other cutoff. Each input pulse causes a reversal of stage; the cutoff transistor is turned on and the conducting transistor is turned off. In the flip-flop shown in Figure 8-6, Q1 is conducting heavily; its collector voltage is only slightly negative and a near-zero voltage is supplied to the base of Q2 (R27-R28 junction). The voltage drop across R24 produces a sufficiently negative voltage at the emitter of Q2 to hold Q2 cut off. With Q2 cut off, the R18/R19/R20 divider delivers a negative voltage to the base of Q1 to keep it conducting.

8-27. At time t_1 the positive input pulse cuts off Q1; the Q1 collector voltage goes negative and drives Q2 into conduction; the Q2 collector voltage and the Q1 base voltage then become less negative permitting Q1 to remain cut off. In a similar manner the positive input pulse at time t_2 cuts off Q2 and starts a sequence of

produces an output waveform with very fast rise and fall

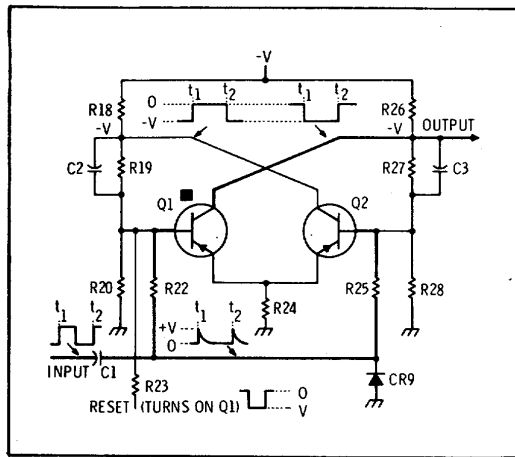

Figure 8-6. Basic Flip-Flop Circuits.

events which ends with Q1 conducting and Q2 cut off. Note that a positive input pulse has no effect on Q1 if it is already cut off. A negative reset pulse applied to the base of Q1 returns the flip-flop to its initial condition (Q1 conducting, Q2 cut off). The diode CR9 removes the negative pulse from the differentiated squarewave input. Without this diode, the negative pulse would drive Q1 which is cut off, and the stage would switch from one state to the other but would not divide by two. The ac coupling through C2 and C3 insures fast switching. The dc coupling through R19 and R27 insures bistable characteristics.

8-28. One-Shot Multivibrator (Figure 8-7). The one-shot multivibrator is a circuit which generates a pulse of some specified duration following the application of a suitable triggering pulse. The circuit is similar to the flip-flop except one dc coupling path has been removed so the circuit is stable only in the state in which Q1 conducts.

8-29. In the typical one-shot multivibrator shown in Figure 8-7, the following conditions exist during the initial stable period: the R5-R6 divider provides a smaller negative voltage to the base of Q2 to hold Q2 off.

8-30. The positive triggering pulse at time t_1 reduces conduction of Q1. The resulting negative-going voltage at the collector of Q1 is applied to the Q2 base through the R3-R4 divider (C2 bypasses R3 to provide coupling for the rapidly changing voltage at the Q1 collector); Q2 begins to conduct; the resulting positive-going change in Q2 collector voltage is coupled through C3 to the base of Q1 to further decrease Q1 conduction. The process is regenerative and quickly results in Q1 being cut off and Q2 being saturated.

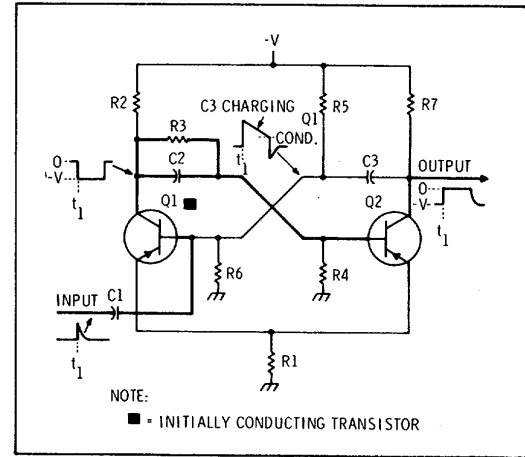

Figure 8-7. Basic One-Shot Multivibrator Circuits.

8-31. Capacitor C3 now charges at a rate mainly determined by the values of R6 and C3 (main charge path: R1-Q2-C3-R5). When the Q1 base voltage becomes sufficiently negative, Q1 begins conducting. The resulting positive-going Q1 collector voltage is coupled to the Q2 base, the Q2 collector voltage goes negative and is coupled through C3 to the Q1 base to further increase Q1 conduction. The process is regenerative and ends with the circuit in its original quiescent state: Q1 saturated and Q2 cut off, until the next pulse is received.

8-32. Field Effect Transistor (FET). Field effect transistors (see Figure 8-8) have three terminals; source, drain, and gate, which correspond in function to emitter, collector, and base of junction transistors. Source and drain leads are attached to the same block (channel) of N or P semiconductor material. A band of oppositely doped material around the channel (between the source and drain leads) is connected to the gate lead.

8-33. In normal FET operation, the gate-source voltage reverse-biases the PN junction, causing an electric field that creates a depletion region in the source-drain channel. In the depletion region the number of available current carriers is reduced as the reverse biasing voltage increases, making source-drain current a function of gate-source voltage. With the input (gate-source) circuit reverse-biased, the FET presents a high impedance to its signal sources (as compared with the low impedance of the forward-biased junction transistor base-emitter circuit). Because there is no input current, FET's have less noise than junction transistors. Figure 8-8 shows the schematic symbol and biasing for N channel and P channel field effect transistors.

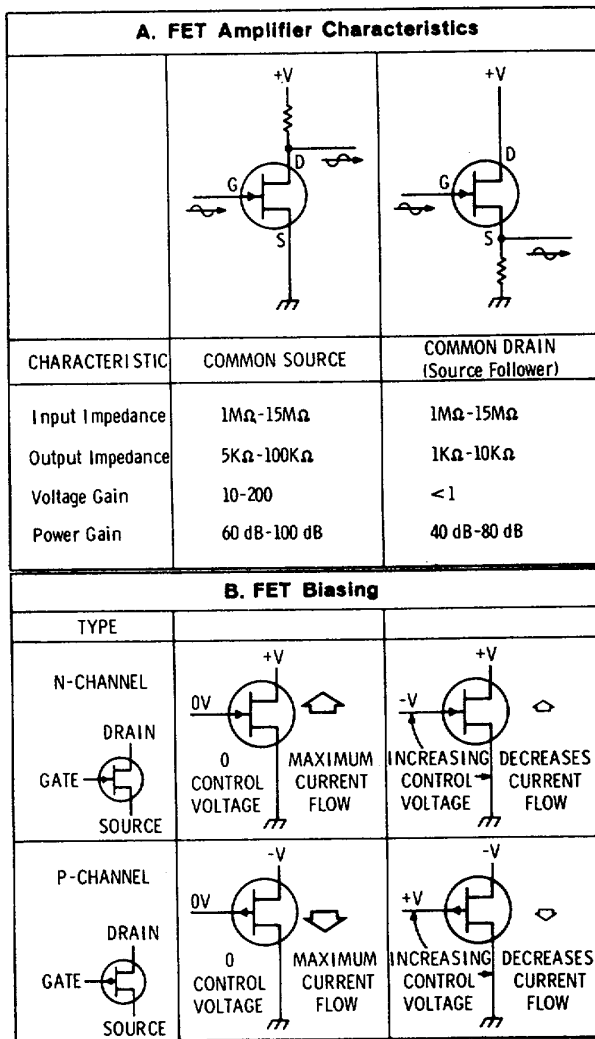

Figure 8-8. Field Effect Transistor Operation.

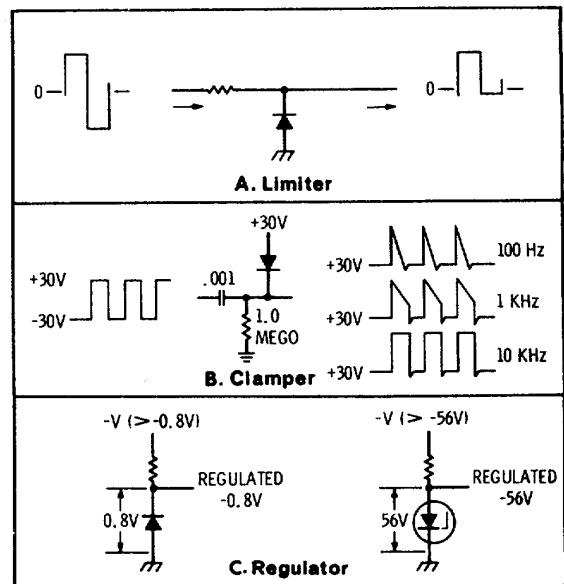

Figure 8-9. Basic Diode Circuits.

8-34. STANDARD DIODE CIRCUITS

8-35. Diode Limiter or Clipper. The limiter or clipper is a circuit which removes positive or negative peaks from a waveform. It can be used either as a waveform shaping circuit or as a protective device to prevent damage from excessive voltages. Figure 8-9, Schematic A, shows a limiter which prevents the negative peak of the pulse from exceeding about X.6 volt. Note that for a conducting silicon diode the cathode voltage is about 0.6 to 0.8 volt more negative than the anode.

8-36. Diode Clamp. The clamper is a circuit which establishes either the positive or negative peak of a waveform at a particular dc reference voltage; in other words, it provides a definite baseline voltage for the waveform. Figure 8-9, Schematic B, shows a clamper which provides a baseline of about +20 volts for a negative pulse.

8-37. Diode Regulator. A diode regulator uses either the constant reverse-bias breakdown voltage characteristic of a breakdown diode or the constant forward-bias voltage drop characteristic of a silicon diode. Power supply reference voltages are generally provided by breakdown diodes which maintain a constant voltage when supplied with a reverse-bias voltage greater than their specified breakdown voltage. Regulated voltages can also be provided by a forward-biased silicon diode which maintains a constant 0.6 to 0.8 volt drop. Figure 8-9, Schematic C, shows connections for both types of diodes.

8-38. SPECIAL TYPES OF SEMICONDUCTORS

8-39. Silicon Controlled Rectifier. An SCR is the semiconductor equivalent of a gas thyatron. A voltage applied to a control element switches the controlled rectifier to a conducting state when a positive voltage is simultaneously applied to the anode. The controlled rectifier continues conducting until the anode voltage is reduced to zero. Once triggered, the control element has no control of the rectifier until it is turned off by removal of the voltage at the anode. Figure 8-10 illustrates the function of an SCR when used as a "crowbar" in a voltage regulation circuit.

8-40. If, when a series regulator transistor fails, it becomes a short circuit, rather than an open circuit, the output voltage can rise to the full value of the rectifier output. Under these conditions the regulator circuits are no longer operative, and the load current is limited mainly by the load resistance. In Figure 8-10 the circuit

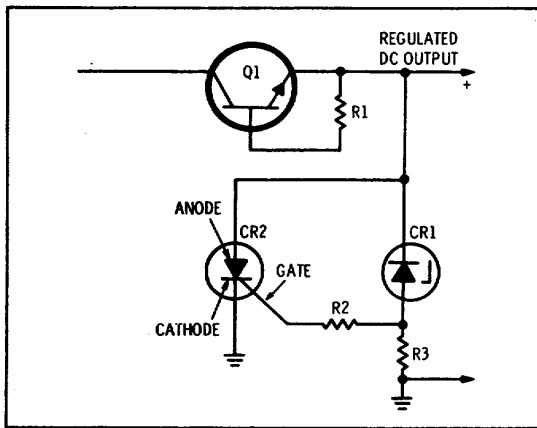

Figure 8-10. Silicon Controlled Rectifier used as a Crowbar.

consisting of CR1, R2, and R3 controls the SCR control element (gate). Since the SCR CR2 is directly across the regulated output, it is always forward biased. However, CR2 cannot conduct until the gate control level triggers it into conduction. When the regulator output voltage increases, the voltage drop across R3 increases. This increase is coupled to the SCR gate through R2. When the SCR gate voltage reaches a predetermined level, the SCR conducts and shorts the output of the regulator to ground. Once triggered into conduction, the SCR continues conducting until the positive voltage at the anode is completely removed. In this manner external circuits are protected from damage due to excessive current flow when the series regulator shorts out and voltage rises.

8-41. Zener Diode. Several types of Zener diodes are used in circuits of the Spectrum Analyzer, mostly in voltage reference applications. These diodes are quite similar, the main differences being current and voltage

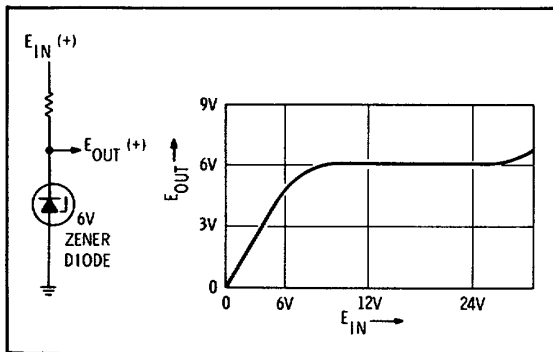

Figure 8-11. Zener Diode Characteristics.

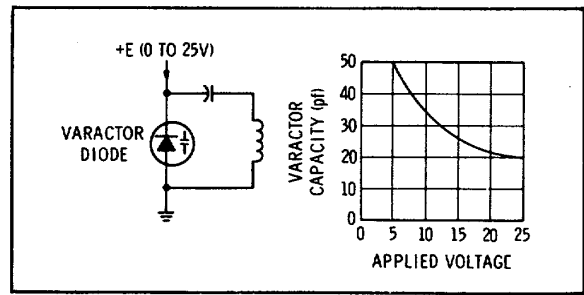

Figure 8-12. Varactor Characteristics.

ratings. When used in a voltage reference application, a Zener diode is connected in the backward or minimum current direction. Figure 8-11 shows a Zener diode circuit and the resultant input and output voltage curve.

8-42. When used in a voltage reference application the Zener current is adjusted so that it is operating on the flat portion of the curve. The Zener diode then resembles a constant-voltage element such as a battery, exhibiting only slight changes in voltage for a change in current.

8-43. Varactor Diode. Ordinary diodes when connected in the back direction exhibit a change in capacitance with a change in applied voltage. The varactor diode is specially designed to produce this effect and exhibits relatively large changes in capacity. Figure 8-12 shows a varactor diode in a resonant tank circuit connected in the back direction with respect to the applied dc voltage. The curve indicates the approximate two-to-one capacitance range for voltage variations from 0 to 25 volts.

8-44. REPAIR

8-45. Part Location Aids. The locations of chassis-mounted parts and major assemblies are shown in Figures 8-18 and 8-19. The locations of individual components mounted on printed circuit boards or other assemblies are shown on the appropriate schematic diagram page or on the page opposite it. The part reference designator is the assembly designator plus the part designator. (Example: A100R9 is R9 on the second converter A10). For specific component description and ordering information refer to the parts list in Section VI.

8-46. Factory Selected Components. Some component values are selected at the time of final checkout at the factory (see Table 5-2). Usually these values are not extremely critical; they are selected to provide optimum compatibility with associated components. These components are identified on

individual schematics by an asterisk. The recommended procedure for replacing a factory-selected part is as follows:

- a. Try the original value, then perform the calibration test specified for the circuit in the performance and adjustment sections of this manual.
- b. If calibration cannot be accomplished, try the typical value shown in the parts list and repeat the test.
- c. If calibration still cannot be accomplished, perform the calibration test using various values until calibration is accomplished.

8-47. Wiring Diagram. Due to the complexity of the system it is not practical to provide an overall schematic diagram. However, Figure 8-23 provides overall wiring information (except for dc voltages) for all switches and assemblies.

8-48. DELETED.

8-49. System Test and Troubleshooting Procedure.

Table 8-4 provides information that will, in most cases, isolate the causes of a malfunction to a circuit or assembly, or to the Display Section.

8-50. No attempt is made in this procedure to isolate causes of trouble to the component level. Reference is made to the specific Service Sheet which describes the circuits and test procedures for the portion of the analyzer to which the malfunction has been isolated.

Where Display Section maintenance is indicated refer to the Display Section Operating and Service Manual.

8-51. Dial Restringing Procedure. An illustrated dial restringing procedure is provided in Figure 8-13.

8-52. Diagram Notes. Figure 8-17, Schematic Diagram Notes, provides information relative to symbols and measurement units shown in schematic diagrams.

8-53. SWITCHING INFORMATION

8-54. The manner in which switch wafers are schematically presented in this manual is distinctly different from that used in previous Hewlett-Packard manuals. If the following information concerning the evolution of this system of switch presentation is carefully studied, it will be seen that circuits are more easily understood and much more easily traced.

8-55. One of the major objections to drawing switch wafer symbols as the wafer appears is that many lines must cross other lines on the schematics. This problem has not been completely eliminated by use of straight-line presentation, but it has been minimized and circuits are much easier to follow once the basic principles are understood.

8-56. Figure 8-14 illustrates the evolution of straight-line switch presentation from the pictorial view of a switch wafer. Part A shows the wafer as it actually appears. In parts B and C, when the wafer is viewed as being a flexible, stretchable material, the transition from wafer to straight-line presentation begins to be obvious. In part D the transition is complete and the wafer now appears to be a slide type switch. In part E the final result is shown. Note that those contacts which maintain contact with the metallic portion of the rotor regardless of switch position (in the illustration contact 7) are moved to the other side for clarification. Note too that lead lines and arrows to switch contacts are no longer required.

8-57. In all schematics in this manual the switches, unless otherwise noted, are shown in the maximum CCW position. The physical layouts of the switches are shown as well as a straight-line presentation of switch action. It is important to note that in the straight-line presentation, the portion of a rotor mating with the bottom contact of a switch mates with the top contact of the switch when the switch is turned one step in the clockwise direction. Switch wafer S1-1F (P/O INPUT ATTENUATION assembly A3) is illustrated in three positions to demonstrate switch action (see Figure 8-15).

8-58. Figure 8-16 illustrates the difference between the old method of switch presentation and the straight line presentation. The example chosen represents the INPUT ATTENUATION switch S1.

Section VIII

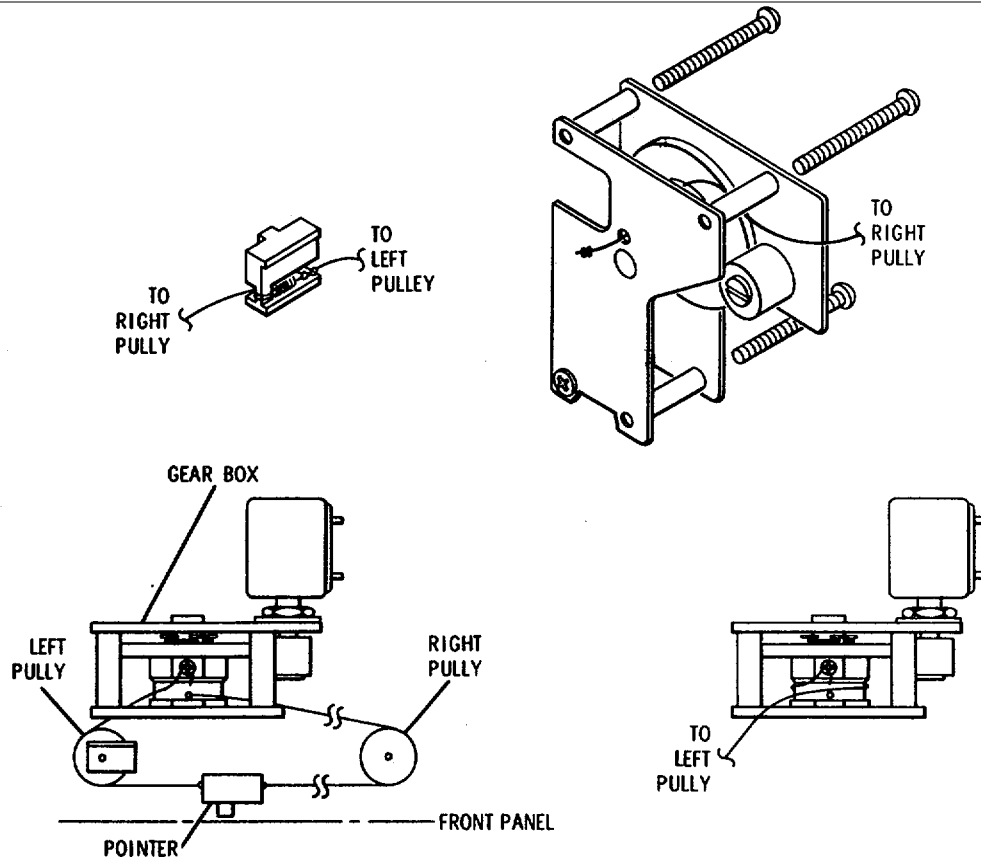

1. Remove top cover.
 - a. Disconnect coax cable from bracket on gear box.
 - b. Tune to low end of scale.
 - c. Remove front panel assembly from side panels.
 - d. Remove scale assembly.
 - e. Remove tuning knobs.
 - f. Remove 3 screws which hold gearbox to panel assembly.
 - g. Remove left pulley at left end of pointer slot.
2. To replace string on right side of pointer:
 - a. Remove pointer from slot, detach old string.
 - b. Access to fixed end of string is through the hole in the front gearbox plate. Line up dial drum with this hole so that old string may be withdrawn.
 - c. Pass a new piece of dial string (about 15-1/2") through the hole and double knot the fixed end. Clip off excess string and draw the knot into the hole.
 - d. Reset the tuning shaft fully ccw.
 - e. Pass the free end of the string into the right end of the pointer slot. Tie it to the pointer spring where it is attached to the pointer.
 - f. Replace pointer in slot.
 - g. Replace gearbox screws.
 - h. Turn shaft fully cw.
 - i. Loosen fixing screw at opposite end of string and adjust string tension so that pointer is stretched 3/16" when string is on pulleys.
 - j. Reassemble, using reverse procedure in 1.
3. To replace string on left side of pointer:
 - a. Remove pointer from slot and remove old string.
 - b. Tie approximately 12" of dial string (use double knot) to the pointer spring and replace pointer in slot.
 - c. Replace gearbox screws.
 - d. Turn shaft fully cw.
 - e. Place dial string on pulleys.
 - f. Wrap string around dial drum, and tie under screwhead, while maintaining about 3/16" stretch on pointer spring.
 - g. Reassemble, using reverse of procedure in 1.
4. Check calibration; adjust by moving the 29 tooth gear on the tuning pot shaft.

Figure 8-13. Dial Restringing Procedure

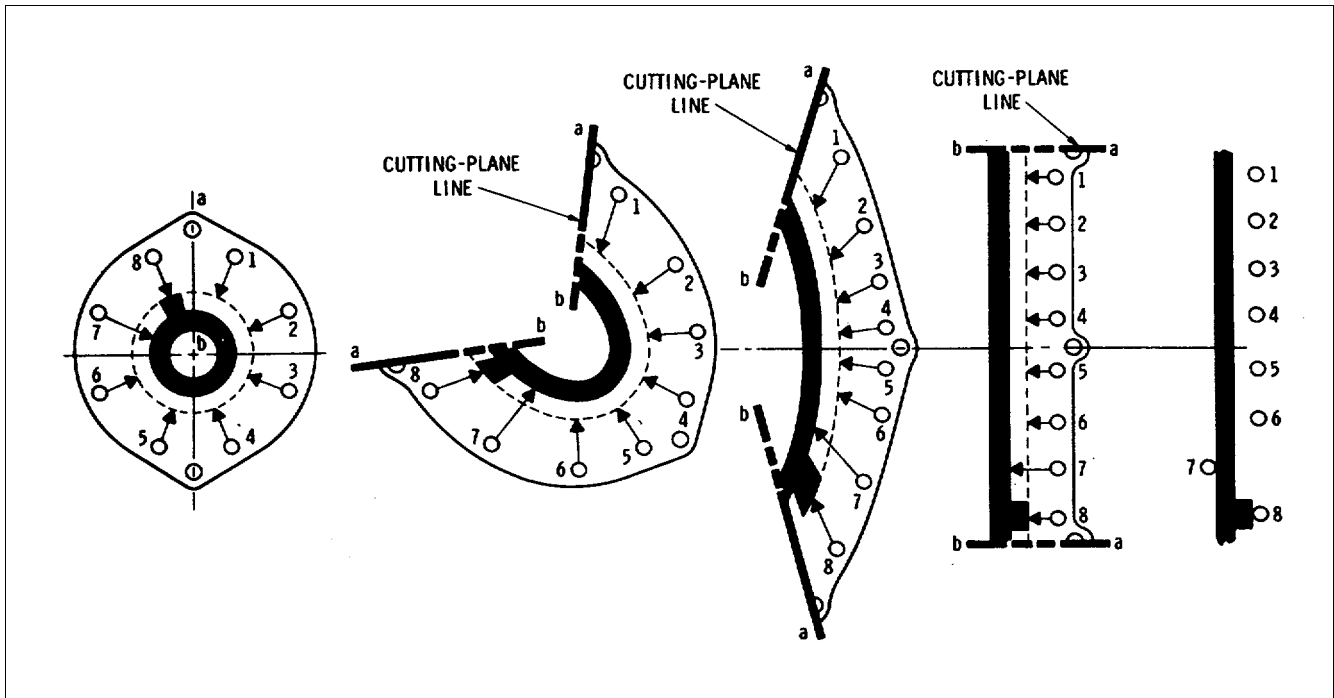

Figure 8-14. Evolution of Straight-Line Switch Presentation

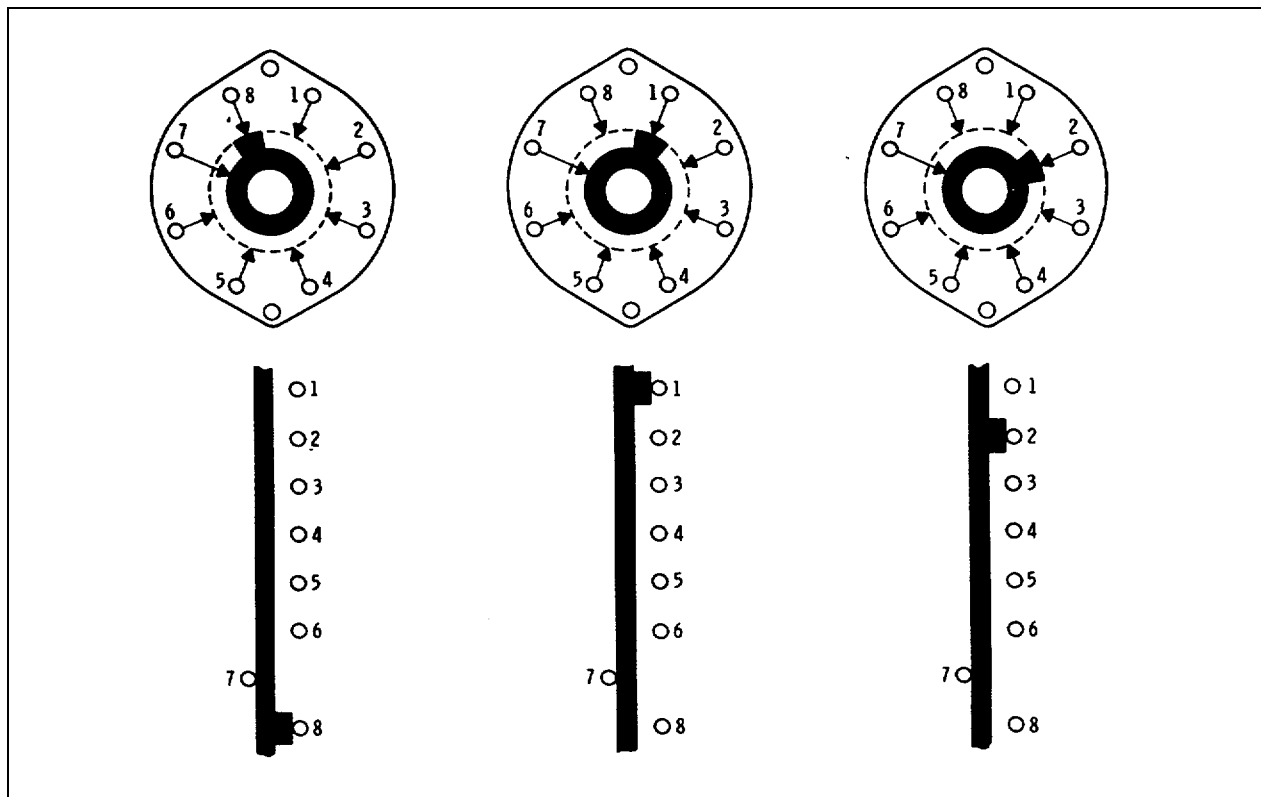

Figure 8-15. Three Positions of Index Light Selector Wafer

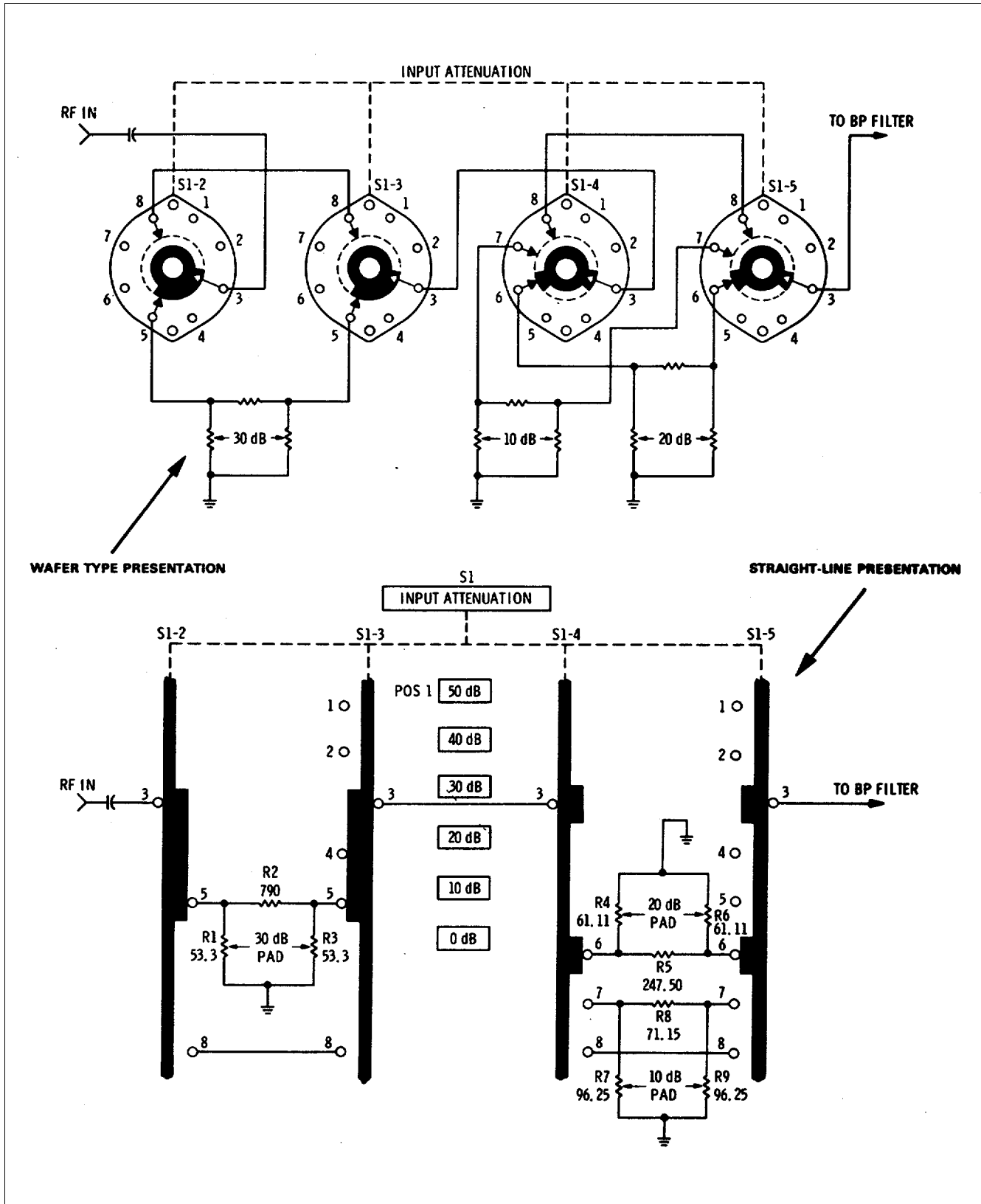

Figure 8-16. Wafer Switch Presentation Versus Straight-Line Presentation

Section VIII

Table 8-4. System Test and Troubleshooting Procedure

TEST	FAULT	PROCEDURE
<p>1. Set POWER switch to ON. Power lamp on, fan operates. Proceed to test 2.</p>	<p>Light not on and/or fan inoperative</p>	<p>Check Display Section</p>
<p>2. Rotate INPUT ATTENUATION control and observe LOG REF LEVEL index lights</p> <p>Lights operate properly. Proceed to test 3</p>	<p>None of the lights illuminate</p> <p>Some, but not all lights illuminate</p>	<p>Check the -12.6 volt supply from Display Section. If voltage is present see Service Sheet 3. If voltage is not present, check the Display Section power supply. Check light bulbs and see Service Sheet 3.</p>
<p>3. Set Analyzer controls as follows: SCAN TIME PER DIVISION..... 5 ms SCAN MODE INT SCAN TRIGGER AUTO and observe SCANNING light</p> <p>Light operates normally. Proceed to test 4.</p>	<p>SCANNING light does not illuminate</p>	<p>See System Test and Troubleshooting Procedure in 8552 Operating and Service Manual. Check power supply circuits.</p>
<p>4. Adjust Display Section for a baseline trace.</p> <p>Baseline trace is normal. Proceed to test 5.</p>	<p>Trace does not appear</p>	<p>See System Test and Troubleshooting Procedure in 8552 Operating and Service Manual. Check scan amplifier, scan generator and horizontal deflection amplifier.</p>
<p>5. Set analyzer controls as follows: FREQUENCY 30 MHz BANDWIDTH 10 MHz FINE TUNE centered SCAN WIDTH PER DIVISION SCAN WIDTH PER DIVISION..... 1 MHz INPUT ATTENUATION..... 10 dB TUNING STABILIZER..... ON RANGE-MHz 0-110 BASE LINE CLIPPER ccw LOG REF LEVEL..... 0 dBm LOG REF LEVEL Vernier ccw LOG/LINEAR LOG VIDEO FILTER OFF SCAN TIME PER DIVISION..... 2 msec Connect CAL OUTPUT to RF INPUT and observe display. The 30 MHz signal should appear close to the center of the display CRT at a level of -30 dBm. If signal is correct, proceed to test 7.</p>	<p>Signal does not appear on Display Section CRT</p>	<p>See System Test and Troubleshooting Procedure in 8552 Operating and Service Manual. Check calibration oscillator. If calibration oscillator is operating properly, go to test 6.</p>

Section VIII

Table 8-4. System Test and Troubleshooting Procedure (cont'd)

TEST	FAULT	PROCEDURE
<p>6. Set analyzer controls as follows: BANDWIDTH 10 kHz FINE TUNE centered SCAN WIDTH . PER DIVISION SCAN WIDTH PER DIVISION 20 kHz INPUT ATTENUATION..... 0 dB TUNING STABILIZER OFF BASELINE CLIPPER..... ccw LOG REF LEVEL..... -30 dBm LOG REF LEVEL Vernier..... ccw LOG/LINEAR..... LOG VIDEO FILTER..... OFF SCAN TIME PER DIVISION 2 msec</p> <p>Connect a 50 MHz -33 dBm signal from the 606B to the W6 jack behind the tuning dial assembly on the top of the 8553 using the 1159260001 cable. Tune the 606B slightly around 50 MHz until the signal is centered. With the AMPL CAL centered the signal should read -30 dBm +2 dBm. If signal is correct, reconnect W6 and proceed to test 7.</p>	<p>Signal incorrect or missing</p>	<p>See System Test and Troubleshooting Procedure in 8552 Operating and Service Manual.</p>
<p>NOTE</p> <p>In steps 7a and 7e it is necessary to simulate the input impedance of the circuit following the point tested to insure accuracy of the meter readings. Use the HP 11563A 50-ohm tee, two HP 1250-0780 BNC jack to type N Plug Adapters, the HP 11593A termination, the HP 11592-60001 subminiature to BNC cable, and the HP 1250-0827 jack-to-jack adapter</p>		
<p>7. Perform the following sub-tests until a malfunction has been found and corrected, then repeat test 5.</p>		

Section VIII

Table 8-4. System Test and Troubleshooting Procedure (cont'd)

TEST	FAULT	PROCEDURE
<p>7-a. Connect HP 8405A to 8553-A7J3 using adapters listed above. Set analyzer CENTER FREQUENCY to 30 MHz and SCAN WIDTH PER DIVISION to ZERO. Meter should indicate about -6 dBm at 230 MHz. If signal is correct, proceed to test 7b.</p>	<p>Signal is missing or incorrect.</p>	<p>Refer to Service Sheet 5 and repair the 200 to 210 MHz voltage tuned oscillator.</p>
<p>7-b. Connect the HP 8405 to 8553 -A10J2. Meter should indicate between -4 dBm and +2 dBm at 150 MHz. If signal is correct, proceed to test 7-c.</p>	<p>Signal is missing or incorrect.</p>	<p>Refer to Service Sheet 9 and repair 150 MHz crystal controlled oscillator.</p>
<p>7-c. Connect the HP 606B output (30 MHz, -10 dBm) to the analyzer RF INPUT and connect the HP 8405A to the output of the 120 MHz Bandpass Filter (blue coax to J2 on A9 assembly), using accessories noted above. Signal should be about -11 dBm. If signal is correct, proceed to test 7-d.</p>	<p>Signal is missing or incorrect</p>	<p>Refer to Service Sheet 3 and repair the attenuator or the bandpass filter.</p>
<p>7-d. With the HP 606B connected as in 7-c, disconnect the W5 coax from J3 on the A10 assembly and connect W5 to the HP 8405A using accessories noted above. Signal should be -6 dBm with analyzer tuned for maximum in ZERO scan. If signal is correct, proceed to test 7-e.</p>	<p>Signal is missing or incorrect</p>	<p>Refer to Service Sheet 4 and repair the 200 MHz IF amplifier assembly.</p>
<p>7-e. With the HP 606B connected as in 7-c, disconnect the W7 from the 50 MHz input under the top cover of the 8552 and connect it to the HP 8405A using the accessories noted above. Signal should be -14 dBm (about) with analyzer tuned for maximum in ZERO scan. If signal is correct, reconnect W7 and proceed to test 8.</p>	<p>Signal is missing or incorrect</p>	<p>Refer to Service Sheet 9 and repair the second converter assembly.</p> <p>See System Test and Troubleshooting Procedure in 8552 Operating & Service Manual. Check 50 MHz converter assy.</p>

Section VIII

Table 8-4. System Test and Troubleshooting Procedure (cont'd)

TEST	FAULT	PROCEDURE
<p>8. Set analyzer controls as follows: FREQUENCY 40 MHz FINE TUNE centered BANDWIDTH 300 kHz SCAN WIDTH 0-100 MHz SCAN WIDTH PER DIVISION 10 MHz INPUT ATTENUATION..... 10 dB RANGE-MHz 0-110 TUNING STABILIZER ON BASE LINE CLIPPER..... ccw SCAN TIME PER DIVISION 2 ms LOG REF LEVEL..... 10 dBm LOG REF LEVEL Vernier ccw LOG/LINEAR..... LOG VIDEO FILTER..... OFF SCAN MODE..... INT SCAN TRIGGER AUTO</p> <p>Connect CAL OUTPUT to RF INPUT using a BNC to BNC cable. The display should be similar to that shown in the procedure column. Vary VERTICAL POSITION to center baseline trace on bottom CRT graticule. Signal amplitude is unimportant in this test. Proceed to test 9.</p>	<p>Sweep does not extend to full width of graticule Not all signals present or improperly spaced.</p> <p>Baseline trace does not vary.</p>	<div data-bbox="1068 317 1438 600" data-label="Image"> </div> <p>See System Test and Troubleshooting Procedure in 8552 Operating and Service Manual. Check Scan Generator and Deflection Amplifier assy's. Same as above. Also refer to Service Sheet 8. First LO summing and shaping amplifier may be defective.</p> <p>See System Test and Troubleshooting Procedure in 8552 Operating and Service Manual. Check vertical deflection circuit.</p>
<p>9. Set LOG REF LEVEL maximum ccw. Set SCAN TIME PER DIVISION to 10 seconds and adjust focus and astigmatism. Adjust trace align to center trace on bottom CRT graticule. Proceed to test 10.</p>	<p>Focus and astigmatism inoperative or trace will not align.</p>	<p>Refer to Display Section Manual and repair as required.</p>
<p>10. Turn FREQUENCY control and observe the marker. Marker should move as FREQUENCY is tuned. Proceed to test 11.</p>	<p>Marker is missing.</p>	<p>Refer to Service Sheet 8 and repair the marker generator.</p>

Section VIII

Table 8-4. System Test and Troubleshooting Procedure (cont'd)

TEST	FAULT	PROCEDURE
<p>11. Tune FREQUENCY control to move the marker exactly under the signal three divisions from the left. The signal will null when the marker is tuned to the exact frequency of the signal. Set SCAN WIDTH PER DIVISION control to 0.05 MHz, BANDWIDTH to 10 kHz, and SCAN WIDTH to PER DIVISION. 30 MHz signal should appear close to the center graticule on the CRT. If correct signal is observed, proceed - to test 12.</p>	<p>30 MHz signal does not appear on CRT.</p>	<p>Check calibration and alignment of the analyzer.</p>
<p>12. Adjust FREQUENCY to center the 30 MHz signal on CRT, then reduce SCAN WIDTH PER DIVISION to 10 kHz and re-center the display with FINE TUNE control. Signal centers properly. Proceed to test 13.</p>	<p>Signal is unstable - FINE TUNE does not vary signal position.</p>	<p>Refer to Service Sheets 6 and 7, and repair APC or reference signal circuits. See System Test and Troubleshooting Procedure in 8552 Operating and Service Manual.</p>
<p>13. Turn LOG REF LEVEL control fully ccw. Top of signal should be at the -70 dB graticule. Rotate LOG REF LEVEL seven steps cw. CRT display should be as shown in the figure. The fault column lists these steps in numerical order beginning with the first step from the ccw position.</p> <p>Set INPUT ATTENUATION to -30 dB and rotate LOG REF LEVEL cw for remaining two steps. Signal amplitude should again reach the top CRT graticule.</p> <p>INPUT ATTENUATION to -10 dB, LOG REF LEVEL to 0 dB. Rotate LOG REF Vernier to full cw. Signal shown should increase by 12 dB. Proceed to test 14.</p>	<p>Each of the first 4 steps: no increase in gain, not 10 dB gain, or loss of signal.</p> <p>Steps 5 & 6 same as above Step 7 same as above Step 8 & 9 same as above All or most levels incorrect and cannot be corrected by adjustment. No change in signal level or change is incorrect. Check gain variable amplifier</p>	<p>See System Test and Troubleshooting Procedure in 8552 Operating and Service Manual.</p> <div data-bbox="1036 1035 1479 1409" data-label="Figure"> </div> <p>Check 3 MHz step gain amplifier Check 3 MHz step gain amplifier Check 3 MHz step gain amplifier</p> <p>Check LIN/LOG amplifier</p>

Section VIII

Table 8-4. System Test and Troubleshooting Procedure (cont'd)

TEST	FAULT	PROCEDURE
<p>14. Set LOG REF LEVEL to -30 dBm (-30 +0). Adjust AMPL CAL so that the top of the signal is exactly on the LOG REF (top) graticule of the CRT. Proceed to test 15.</p>	<p>AMPL CAL does not vary signal level.</p>	<p>See System Test and Troubleshooting Procedure in 8552 Operating and Service Manual.</p>
<p>15. Set LOG/LINEAR to LINEAR and LINEAR SENSITIVITY to 1 mV/Div. The CRT deflection should be adjusted by the AMPL CAL control to 7.07 divisions. If display is correct proceed to test 16.</p>	<p>AMPL CAL can not be adjusted for 7.07 division display</p>	<p>See System Test and Troubleshooting Procedure in 8552 Operating and Service Manual and Service Sheet 3. Probable trouble is in linear amplifier compensation circuit or 8552 Lin/Log Amplifier Assy.</p>
<p>16. Set analyzer controls as follows: SCAN WIDTH 0-100 MHz SCAN WIDTH PER DIVISION 10 MHz BANDWIDTH 10 kHz LOG/LINEAR..... .LOG LOG REF LEVEL..... -10 dBm</p> <p>Turn BASE LINE CLIPPER full ccw.</p> <p>Switch SCAN TIME PER DIVISION through its range.</p> <p>Return SCAN TIME PER DIVISION to 2 ms.</p> <p>Set SCAN WIDTH to PER DIVISION not illuminate</p>	<p>Bottom two divisions of CRT not blanked.</p> <p>Scan does not occur in all positions</p> <p>DISPLAY UNCAL does or switching circuits.</p>	<p>See System Test and Troubleshooting Procedure in 8552 Operating and Service Manual.</p> <p>Check base line clipper circuit.</p> <p>Check scan generator circuit.</p> <p>Refer to Service Sheet 12. Probable cause of trouble is in the analogic circuit Check DS1.</p>

Section VIII

SCHEMATIC DIAGRAM NOTES

Resistance in ohms and capacitance is in picofarads and inductance is in microhenries unless otherwise noted.

P/O = part of.

*Asterisk denotes a factory-selected value. Value shown is typical. Capacitors may be omitted or resistors jumpered.

- 

Screwdriver adjustment.





Panel control.
- 

Encloses front panel designations.

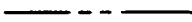

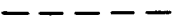

Encloses rear panel designation.
- 

Circuit assembly borderline.
- 

Other assembly borderline.
- 

Heavy line with arrows indicates path and direction of main signal.
- 

Heavy dashed line with arrows indicates path and direction of main feedback.
- 

Wiper moves toward CW with clockwise rotation of control as viewed from shaft or knob.
- 

Numbers in circles on circuit assemblies show locations of test points.
- 

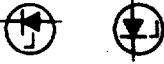
Encloses wire color code. Code used (MIL-STD-681) is the same as the resistor color code. First number identifies the base color, second number the wider stripe, and the third number identifies the narrower stripe. E.g., (947) denotes white base, yellow wide stripe, violet narrow stripe.
- 

Voltage regulator (breakdown diode).
- 

Denotes Field Effect transistor (FET) with N-type base.
- 

Denotes FET with P-type base.
- 

Denotes Capacitive diode (Varicap, varactor).
- 

Denotes Silicon Controlled Rectifier.
- 

P-Type Metal Oxide Substrate FET (MOSFET)
- 

N-Type Metal Oxide Substrate FET (MOSFET)

Figure 8-17. Schematic Diagram Notes

**SERVICE SHEET 1
BLOCK DIAGRAM**

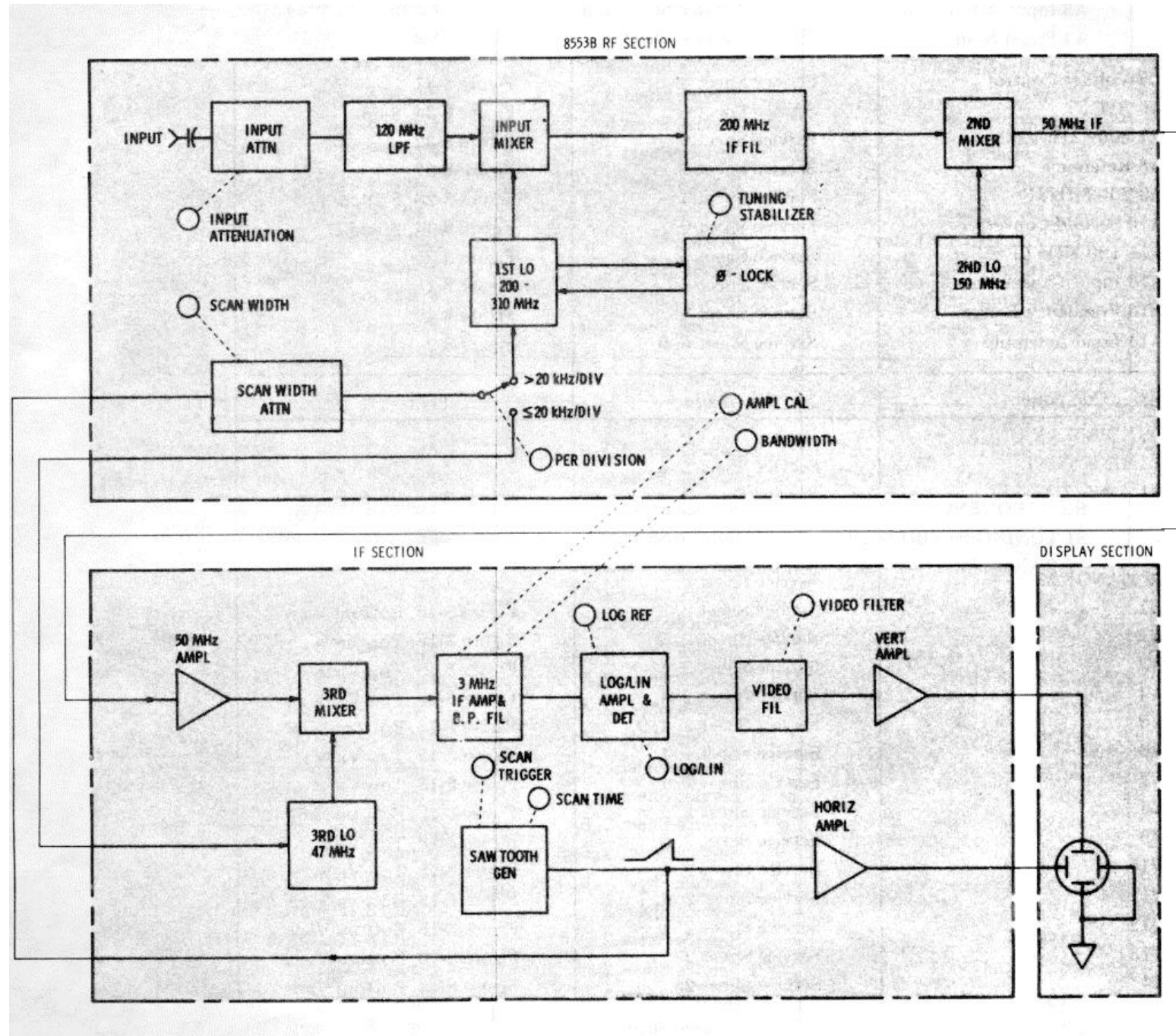

Simplified Analyzer Block Diagram

← 8553B ASSEMBLY AND ADJUSTMENT LOCATIONS

1 INPUT CAPACITOR ASSEMBLY A12

Input blocking capacitor A12C1 protects the diodes in the first balanced mixer when a signal containing dc components is applied to the analyzer.

2 INPUT ATTENUATOR AND LOW PASS FILTER

The input attenuator contains three fixed, pad type attenuators of 10, 20 and 30 dB. Switch positions select one or two of the pads or straight through wiring in six different combinations, to provide 0 to 50 dB attenuation in 10 dB steps.

Ganged with the input attenuator, but not a part of the input attenuation circuit, is a wafer which provides power to the index lamps associated with the LOG REF LEVEL LINEAR SENSITIVITY control. This wafer also provides a control to the IF section log/lin amplifier which is used when the analyzer is operated in the LINEAR mode.

The Low Pass Filter response is essentially flat up to 110 MHz. Attenuation at 130 MHz is approximately 3 dB and maximum signal rejection is between 400 and 510 MHz.

3 200 MHz IF ASSEMBLY

The first mixer is a double balanced diode quad that up-converts the input rf signals by mixing them with the output of the first local oscillator. The resulting 200 MHz IF signals are amplified 14 dB and applied to the second converter through a 200 MHz + 2 MHz filter.

4 200-310 MHz VOLTAGE TUNED OSCILLATOR

The main frequency determining element in the first local oscillator is a varactor which is controlled by a dc level or a varying ramp from the voltage control assembly. The VTO assembly contains a power amplifier and separate buffer stages to provide an output to the first mixer, the Automatic Phase Compensation circuit, and a rear panel monitor connector.

The first local oscillator may be swept through its entire operational range or selected portions of it, by a voltage ramp from the voltage control assembly. In narrow scan modes or in ZERO scan mode the first local oscillator is phase locked to the 100 kHz reference signal.

5 AUTOMATIC PHASE COMPENSATION ASSY

The 100 kHz reference signal controls a sampling pulse generator which turns on a diode quad gate to sample the output of the first local oscillator. After phase lock has been accomplished this signal sample is used to provide an error signal to maintain the phase locked condition. The APC assembly also provides an output signal which is used to produce an offset signal to shift the IF Section 47 MHz oscillator frequency and maintain display accuracy.

6 REFERENCE ASSEMBLY

The 100 kHz reference signal is developed in the reference assembly from a 1 MHz crystal controlled oscillator by means of divide-by-five and divide-by-two circuits. The reference signal provides a means of phase locking the first local oscillator to a stable reference.

The memory amplifier provides the offset voltage to shift the IF section 47 MHz oscillator an amount equal to the frequency shift required to phase lock the first local oscillator. This is necessary to prevent CRT display shift when the analyzer is operated in the stabilized mode.

7 VOLTAGE CONTROL ASSY CIRCUITS

The first local oscillator summing amplifier combines the ramp voltage from the SCAN WIDTH switch, the APC signal, and the dc level established by the position of the FREQUENCY control. In ZERO and PER DIVISION modes of operation this composite signal is applied to the first local oscillator shaping circuit for processing. In the 0 to 100 MHz mode, the DC tune voltage is applied to the marker generator.

The first local oscillator shaping amplifier shapes the sweep tuning ramp. As the sweep voltage increases, diodes sequentially turn on parallel resistive networks to control the gain of the shaping amplifier. The shaping amplifier output is exponential ramp which changes the varactor capacity in the first local oscillator to produce linear frequency change with respect to time.

8 FREQUENCY RANGE ASSEMBLY

Controls the tuning range of the FREQUENCY control. Divides DC tune voltage by 10 to provide 0-11 MHz frequency scale.

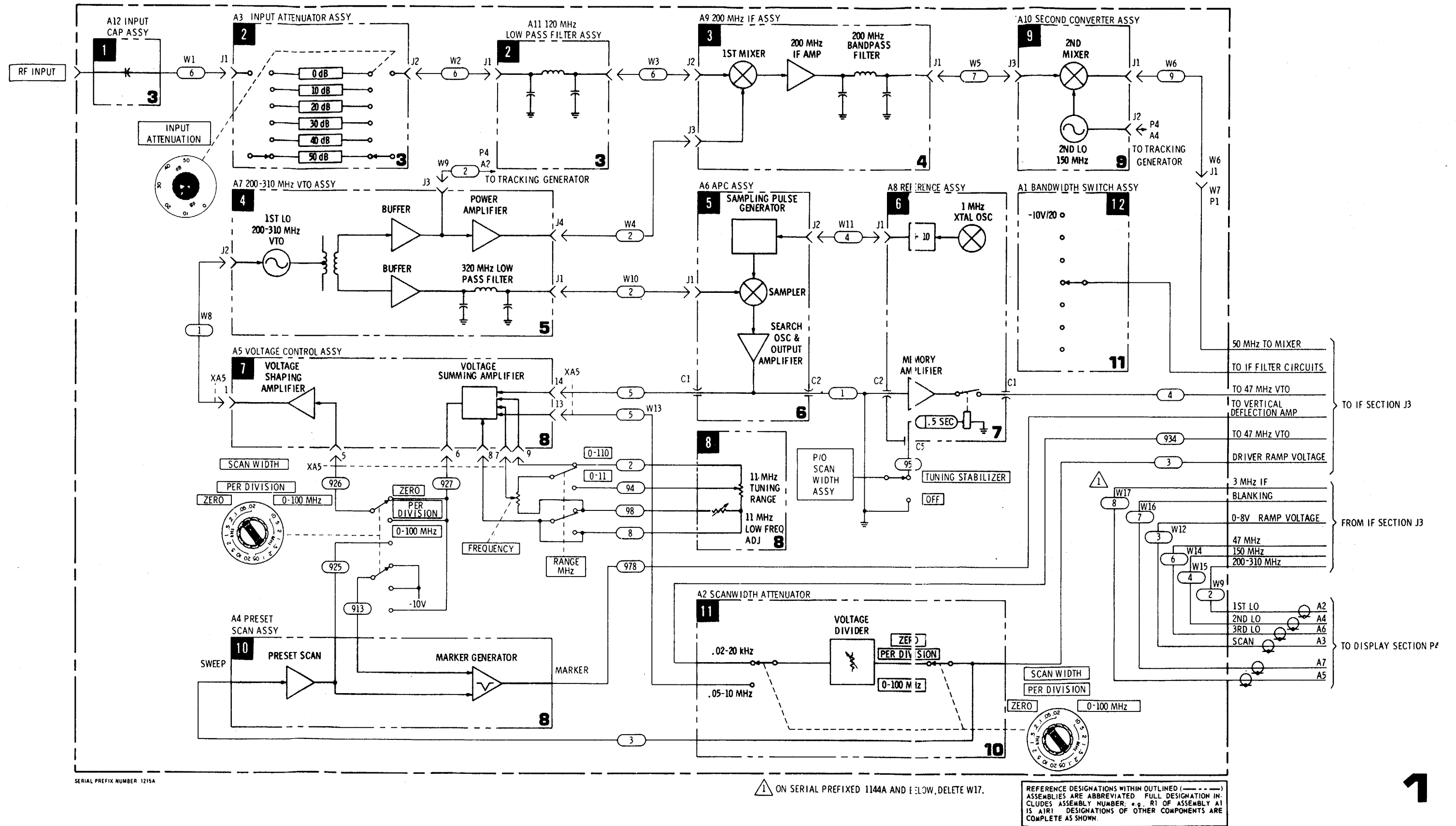

Figure 8-19. Block Diagram of 8553B RF Section

SERVICE SHEET 2 (1 of 3)

SWITCHING INFORMATION (General)

Unless otherwise noted, all switches shown in this manual are shown in the full composition. For information concerning switch symbols used, see Paragraphs 8-53 through 8-58.

The bandwidth switch assembly provides dc levels to

operate diode switching matrixes in the IF section LC Filter and Crystal Filter circuits to switch components in or out of the circuits to control the bandwidth. It also provides a dc level to operate bypass paths in the Crystal Filter circuits when bandwidths of 10 kHz or greater are chosen.

A separate wafer of the switch provides current to a summing bus for the analogic circuit.

Switch wafers S1-2F, S1-1R, S1-2R, and part of S2-5R provides a variable voltage divider which attenuates the scan ramp voltage to determine the scan width per division (Service Sheet 9).

Part of switch wafers S2-5F and S2-5R (Service Sheets 2 and 8) provide coupling between the RF section summing amplifier, shaping amplifier, RF section marker generator, and/or the preset scan assembly depending on the selected mode of operation.

Switch wafer S1-3R controls the automatic phase compensation circuit (Service Sheet 8).

Part of switch wafer S2-5F works in conjunction with the BANDWIDTH switch (Service Sheet 11).

Switch wafers S1-4F and S1-4R provides current to the analogic circuit to aid in illuminating the DISPLAY UNCAL light when analyzer control settings are not compatible with calibrated operation.

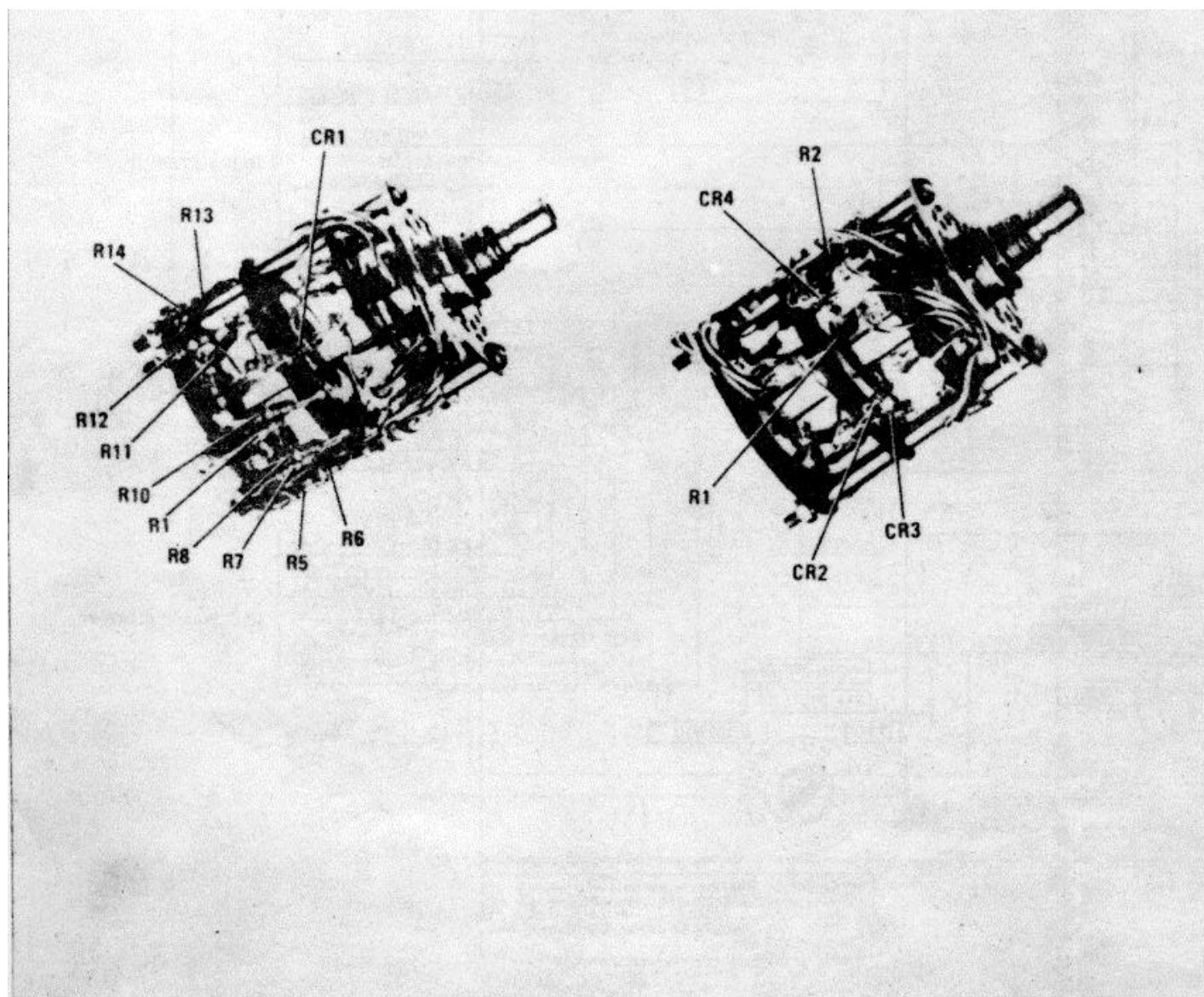

Figure 8-20. Bandwidth Switch Assembly A1 (08553-60126)

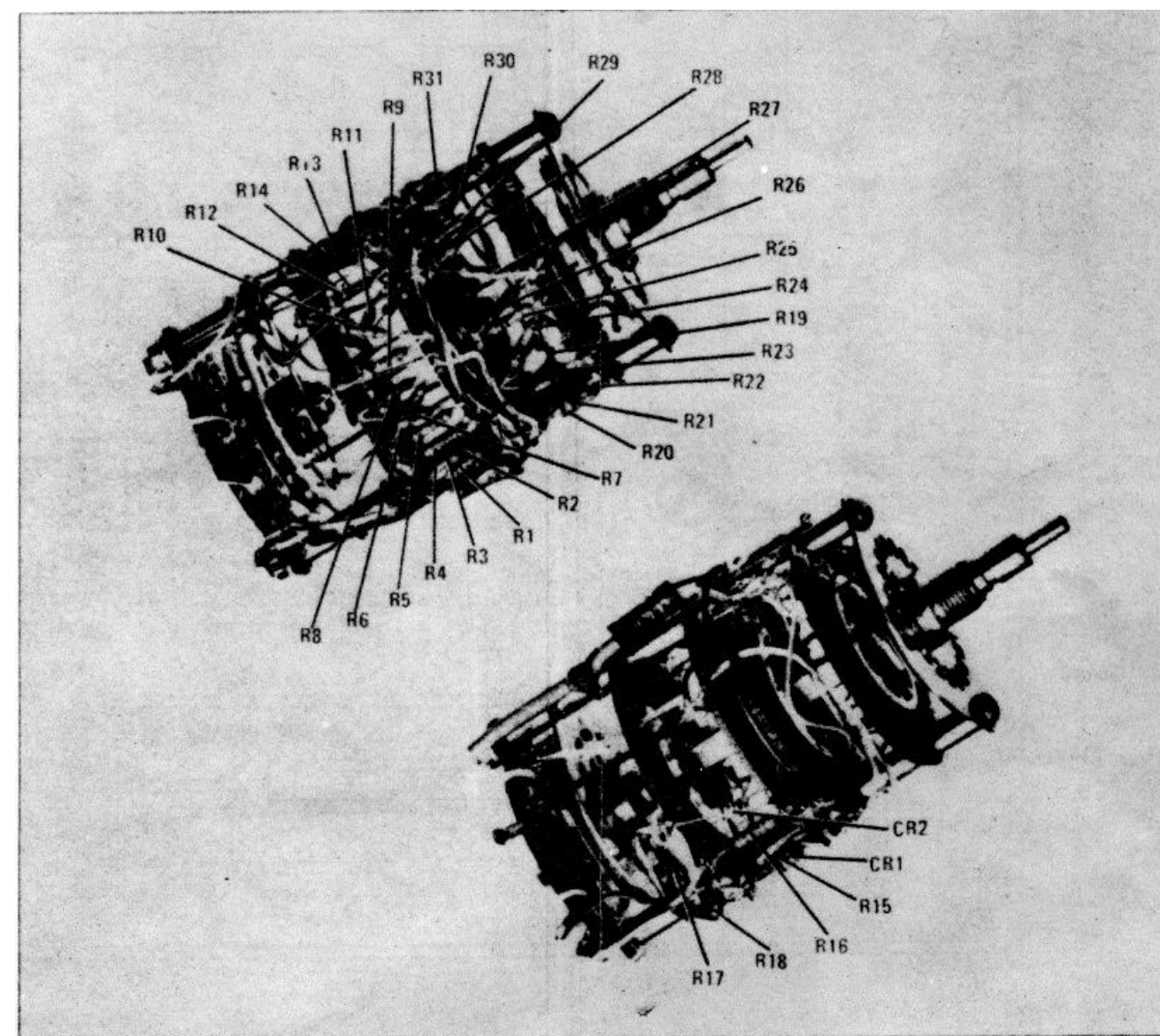

Figure 8-21. Scan Width Attenuator Assembly A2 (08553-60125)

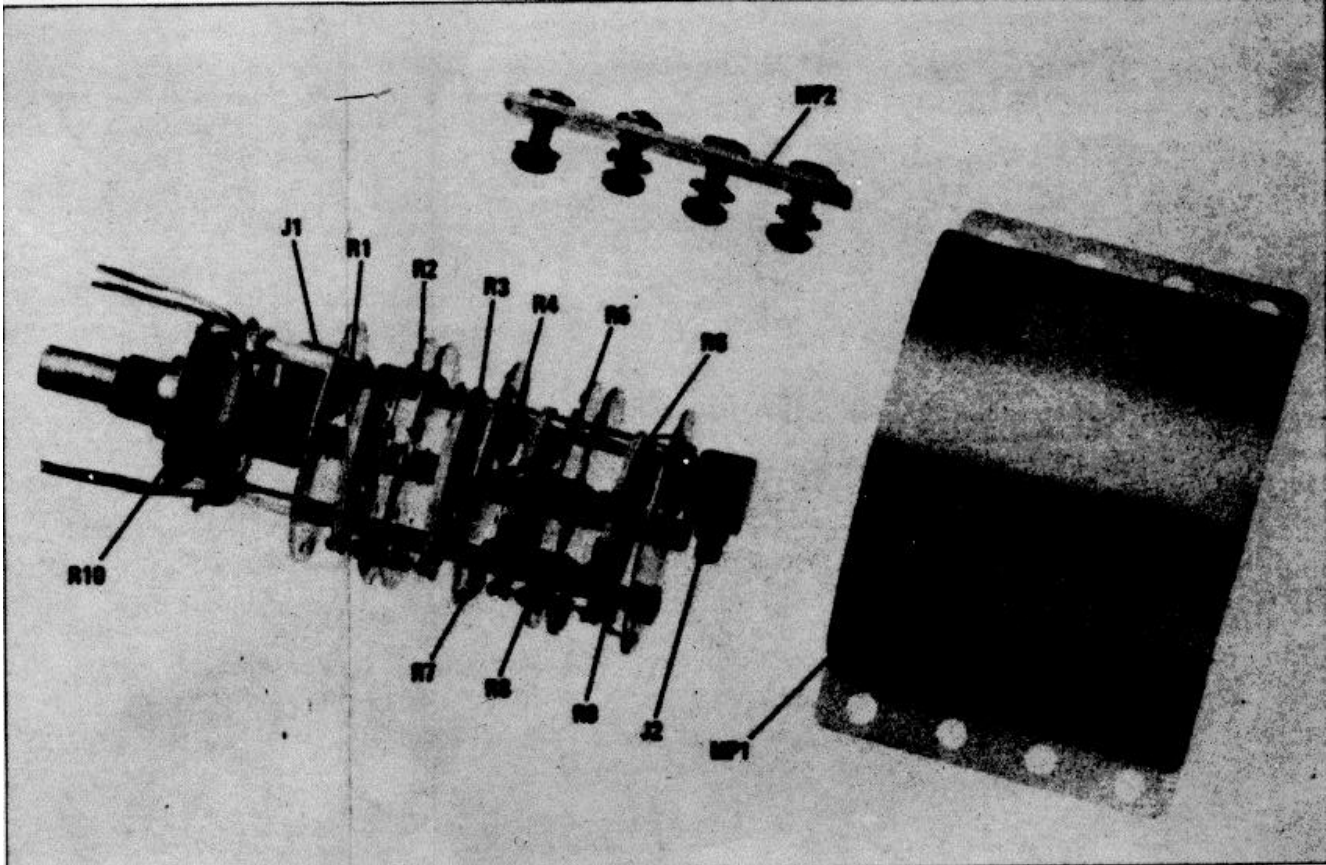

Figure 8-22. Input Attenuation Assembly A3 (08553-6021)

Table 8-6. 8553B Cable Connections

Cable	Wire Color Code	Function	Connections
W1	6	Connects input signal from A12 Input Capacitor Assy to A3 Input Attenuator Assy	A12P1-A11J1
W2	6	Connects output signal from A3 Input Attenuator Assy to A11 120 MHz Low Pass Filter Assy	A3J2-A11J1
W3	6	Connects output signal from A11 120 MHz Low Pass Filter Assy to A9 200 MHz IF Assy	A11J2-A9J2
W4	2	Connects A7 200-310 MHz VTO Assy LO output to A9 200 MHz IF Assy	A7J4-A9J3
W5	7	Connects A7 200 MHz IF signal to A10 Second Converter	A9J1-A10J3
W6	9	Connects A10 50 MHz signal to W7	A10J1-W7P1
W7	Clear	Connects 50 MHz signal from W6 to interconnect jack J3	W7P1-J3A1
W8	1	Connects A5 Voltage Control output to A7 200-310 MHz VTO Assy	XA5-1 - A7J2
W9	2	Connects A7 200-310 MHz VTO Assy to P4	A7J3-P4A2
W10	2	Connects A7 200-310 MHz VTO Assy to A6 APC Assy	A7J1-A6J1
W11	4	Connects A8 Reference Assy to A6 APC Assy	A8J1-A6J2
W12	3	Connects 8552A Ramp voltage from J3 to P4	J3 Pin 14-P4A3
W13	5	Connects ramp voltage from A2 Scan Width Attenuator Assy to A5 Voltage Control Assy	A2S1-19 -XA5-13
W14	6	Connects 8552A 47 MHz LO from J3 to P4	J3A2-P4A6
W15	4	Connects A10 Second Converter Assy to P4	A10J2-P4A4
W16	7	Connects 8552A Scan and Blanking signals from J3 to P4	J3 Pin 13-P4A7

Section VIII**9 SECOND CONVERTER ASSEMBLY**

The second converter assembly consists of a 150 MHz crystal controlled oscillator and a double balanced mixer. The input from the 200 MHz IF amplifier is down-converted to 50 MHz and applied to the 50 MHz amplifier in the IF Section.

10 PRESET SCAN ASSEMBLY

The Preset Scan Assembly applies a preset scan voltage to the A5 shaping amplifier in the 0-100 MHz scan. The Preset scan voltage also generates an inverted marker which is supplied to the display section. This inverted marker is analogous to the center frequency to which the analyzer is tuned. When the

analyzer is operated in the PER DIVISION or ZERO mode the marker generator is disabled.

11 SCAN WIDTH ATTENUATOR ASSEMBLY

This portion of the scan width attenuator assembly contains the resistive network and switching to attenuate the scan generator ramp voltages to the correct level, for the .02 kHz to 10 MHz per division modes.

12 BANDWIDTH SWITCH ASSEMBLY

This switch controls the LC and crystal bandpass circuits in the IF section. In the 0-100 MHz mode the 300 kHz bandwidth is automatically selected.

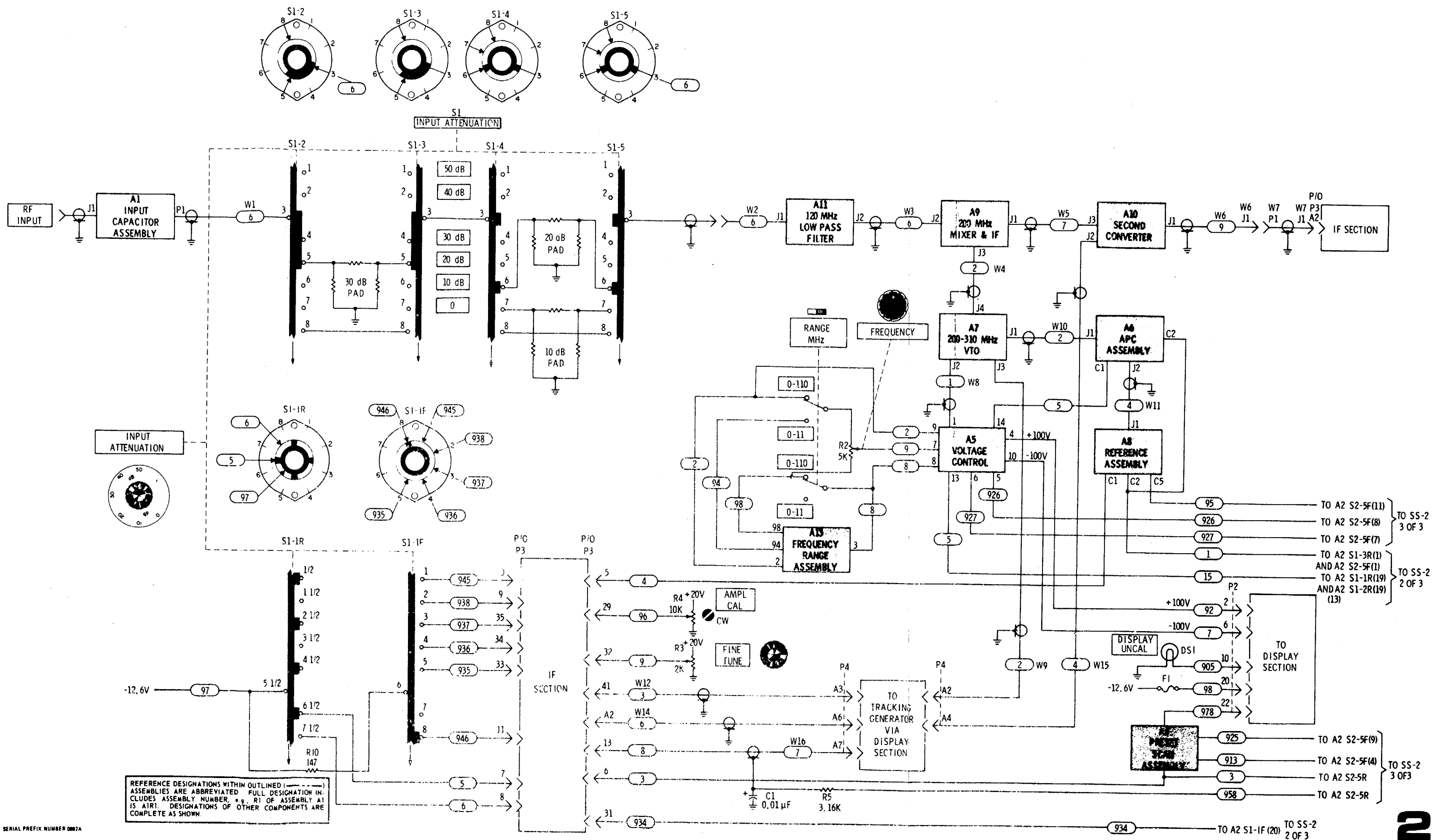

Figure 8-23. Overall Wiring and Switching Diagram (1 of 3)

Section VIII

Table 8-7. 8553B Plug and Jack Identifier

Connector	Wire Color	Function	Wire Connector	Function Code	
P3		RF Unit-IF Unit Interconnection	P2	Main Frame Interconnections	
Pin 1	912	0.05 kHz Bandwidth	Pin 1	924	Blanking - connected to Pin 4
2	913	0.1 kHz Bandwidth	2	92	+ 100 volts
3	914	0.3 kHz Bandwidth	3		Open
4	915	1 kHz Bandwidth	4		Blanking - connected to Pin 1
5	4	Phase Lock Compensation	5		Open
6	3	Preset Scan Voltage	6	7	-100 volts
7	5	Linear Compensation Control Voltage	7 - 9		Open
8	6	Linear Compensation Control Voltage	10	905	Uncal Display Light
9	938	Log Ref Level Lamp No. 4	11	Fine	Horizontal Deflection -
10	945	Log Ref Level Lamp No. 5		Wire	connected to Pin 12
11	946	Log Ref Level Lamp No. 6	12		Horizontal Deflection -
12	90	Sensing Ground for TG			connected to Pin 11
13	8	Blanking for Tracking Generator	13-15		Open
14	925		16	92	+100 volts - connected to Pin 2
15-24		Open	17-20		Open
25	916	10 kHz Bandwidth	21	97	-12.6 volts
26	917	30 kHz Bandwidth	22	978	Preset Scan Voltage
27	918	100 kHz Bandwidth	23	Fine	Horizontal Deflection - connected
28	923	300 kHz Bandwidth		Wire	to Pin 24
29	96	Ampl Cal Adjustment 24			Horizontal Deflection - connected
30	957	Normal Analogic Line			to Pin 23
31	934	Scan Voltage to IF Sect. 47 MHz Osc.			
32	9	Fine Tune Voltage to IF Section 47 MHz Osc.			
33	935	Log Ref Level Lamp No. 1	P4		Tracking Generator Controls via Mainframe
34	936	Log Ref Level Lamp No. 2			
35	937	Log Ref Level Lamp No. 3	A1		Not connected
36	907	-10 volts	A2	2	First Local Oscillator Signal
37	902	+20 volts	A3	3	Shield Marker Position-Center Scan
38	956	Video Filter Analogic Line	A4	4	Second Local Oscillator Signal
39	958	Zero Scan Analogic Disable Line	A5		Not connected
40		Open	A6	6	47 MHz Oscillator Signal
41	3	0 to 8 v ramp-scan control to tracking generator	A7	7	Shield: Zero Scan
A1	Clear	W7 - 50 MHz IF A8			Center: Blanking
A2	6	47 MHz Auxiliary Line			Not connected

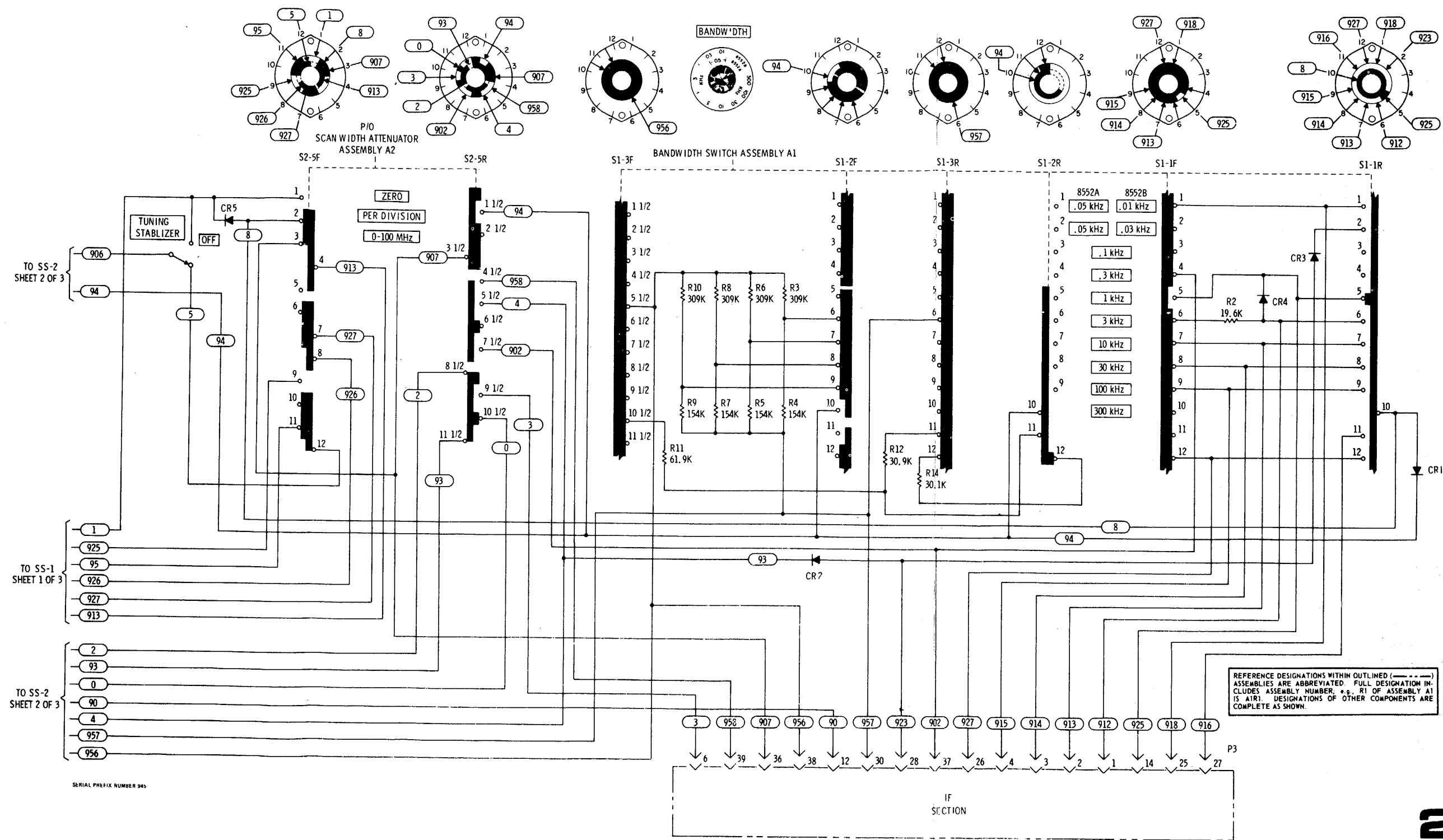

Figure 8-23. Overall Wiring and Switching Diagram (3 of 3)

SERVICE SHEET 3

It is assumed that one or more of the following conditions exist:

1. The steps specified in Section IV, Paragraphs 4-12 through 4-13 have been performed; that only the marker and first local oscillator signals appear on the Display CRT, and that there is no rf input to first converter A9 with an rf input signal applied at J1. (Follow steps 1, 2, and 3.
2. The index lamps do not function properly. (Follow step 4.)
3. Linear sensitivity as displayed on the CRT is incorrect. (Follow step 5.)

TROUBLESHOOTING PROCEDURE

Since there are no active components in the circuits to be tested, the 8553B should be disconnected from the IF section and the mainframe.

Following the procedures under individual circuit descriptions should isolate the defective circuit or component.

All rf tests are conducted with a 30 MHz, -10 dBm signal applied to RF INPUT connector J1.

EQUIPMENT REQUIRED

Vector Voltmeter	HP 8405A
Volt-ohm-ammeter	HP 410C
Service Kit	HP 11592A 50-
Ohm Termination	HP 11593A
Signal Generator	HP 606B
Cable Assembly (2)	HP 10503A
Jack-to-Jack Adapter	HP 1250-0827
BNC Tee	UG 274 B/U

CONTROL SETTINGS.

As specified in individual tests.

1. INPUT CAPACITOR ASSEMBLY A12

Input blocking capacitor A12C1 protects the diodes in the first mixer during application of signals containing a dc component. The breakdown voltage of the capacitor is in excess of 50 Vdcw. From 1 kHz to 110 MHz, the response of C1 is essentially flat.

TEST PROCEDURE

Disconnect the output connector from the A12 assembly. Connect the HP 8405A to the A12 assembly TPA using the test cable, BNC tee and 50-ohm load. This meter should indicate -10 dBm.

If an incorrect reading is obtained the A12 assembly or

the rf input jack J1 may be defective. If the correct reading is obtained reconnect A12 and proceed to step 2.

2. INPUT ATTENUATION ASSEMBLY A3.

Input attenuation assembly A3 provides 0 to 50 dB attenuation in 10 dB steps using three fixed, pad type attenuators of 10, 20, and 30 dB. The INPUT ATTENUATION control is mainly used to reduce the rf signal level applied to the first mixer to --40 dBm or less. This minimizes distortion products generated in the mixer by operating the mixer in its linear region. The flat frequency response and attenuator accuracy contribute to the analyzer's absolute amplitude calibration.

TEST PROCEDURE

Since the input attenuator is difficult to remove, it should be tested in place and tests should include cable W1 and W2. With the HP 8405A connected to the output end of cable W2, TP B (using the BNC tee, 50-ohm load, and jack-to-jack adapter) and a 30 MHz, -10 dBm signal applied to the RF INPUT, rotate the INPUT ATTENUATION control and observe the meter for the following indications: 0 dB 10 dBm, 10 dB 20 dBm, 20 dB 30 dBm, 30 dB 40 dBm, 40 dB -50 dBm, 50 dB 60 dBm. If the correct meter readings are not observed the trouble is probably in Cable W1, Cable W2, or the attenuator assembly. If the readings are correct proceed to step 3.

3. 20 MHz LOW PASS FILTER A11.

The 120 MHz Low Pass Filter is essentially flat up to 120 MHz, skirted to provide 3 dB of attenuation at 130 MHz, and provides maximum rejection between 400 and 510 MHz.

TEST PROCEDURE:

With an rf input signal connected as in previous steps, connect the HP 8405A (using the BNC Tee and the 50 ohm load) to output connector J2 (TP C). With INPUT ATTENUATION set to 0 dB and a -10 dBm signal applied to RF INPUT J1, a reading of approximately -10.5 dBm should be obtained. If reading is incorrect, the filter is probably defective; if reading is correct, cable W3 to first converter assembly A9 may be defective.

NOTE: If the low pass filter is replaced, it should be aligned in accordance with Paragraph 5-26 of Section V.

←SERVICE SHEET 2 (3 of 3)

Overall Wiring and Switching Diagram

4 INDEX LIGHT SELECTOR A3S1-1F

Index light selection wafer A3S1-1F, on the INPUT ATTENUATION control, selects the index light associated with the LOG REF LEVEL/ LINEAR SENSITIVITY control in the analyzer IF section. In LOG mode, the selected index lamp is opposite the scale factor on the LOG REF LEVEL control that corresponds to full-scale deflection on the display. In LINEAR mode, the selected index light is opposite the LINEAR SENSITIVITY PER DIVISION scale factor. Lights DS1 through DS6 provide a moveable index point, positioned by the INPUT ATTENUATION control, corresponding to the analyzer's overall gain and amplitude scale calibration factor.

TEST PROCEDURE

Turn instrument off. Connect the ground lead of the HP 410C to fuse FI. Rotate the INPUT ATTENUATION control and check for a reading of 147 ohms at connector pins of P3 as follows: 0 dB pin 33, 10 dB pin 34, 20 dB pin 35, 30 dB pin 9, 40 dB pin 10, and 50 dB pin 11. If the 147 ohm reading is not obtained at any setting R10 or FI may be defective. If the reading is obtained at some, but not all positions, switch section S1 1F or wiring is probably defective.

5. LINEAR AMPLIFIER COMPENSATION SELECTOR A3S1-1R

Part of amplifier compensation, for 10 dB steps of INPUT ATTENUATION control, when analyzer is in LINEAR mode. Refer to IF Section Operating and Service Manual for detailed circuit description

TEST PROCEDURE

Connect the ground lead of the HP 410C to fuse FI. Connect the other lead to P3 pin 7. Meter should indicate continuity at 50 dB, 30 dB, and 20 dB positions of INPUT ATTENUATION control. Move connection from P3 pin 7 to P3 pin 8. Meter should indicate continuity at 40 dB, 20 dB, and 0 dB positions of INPUT ATTENUATION control. If readings are correct, trouble should be in IF Section wiring. If indications are incorrect, check S11R and 8553B wiring.

6. PROBE POWER

Provides power to 1121A Active Probe. Probe provides measurement access to high impedance, high frequency circuits. Power available for probe use is +15V (±5%) and -12.6V (±2%).

Simplified Test Procedure Tree

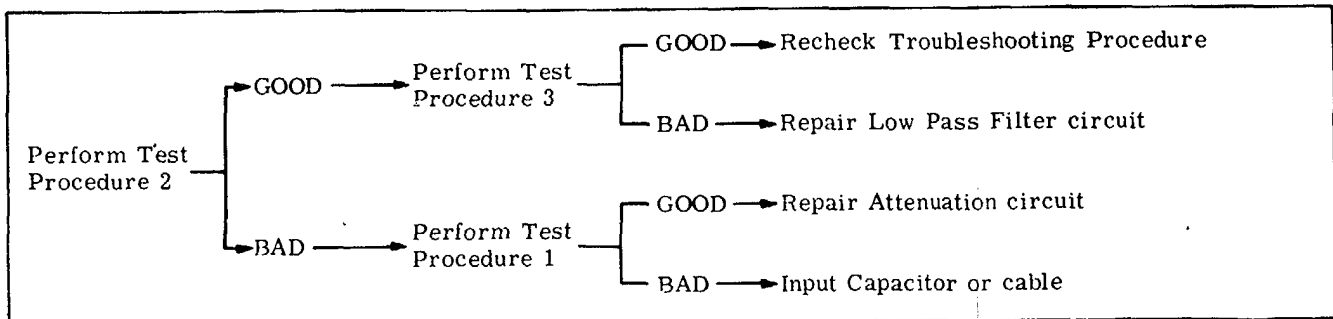

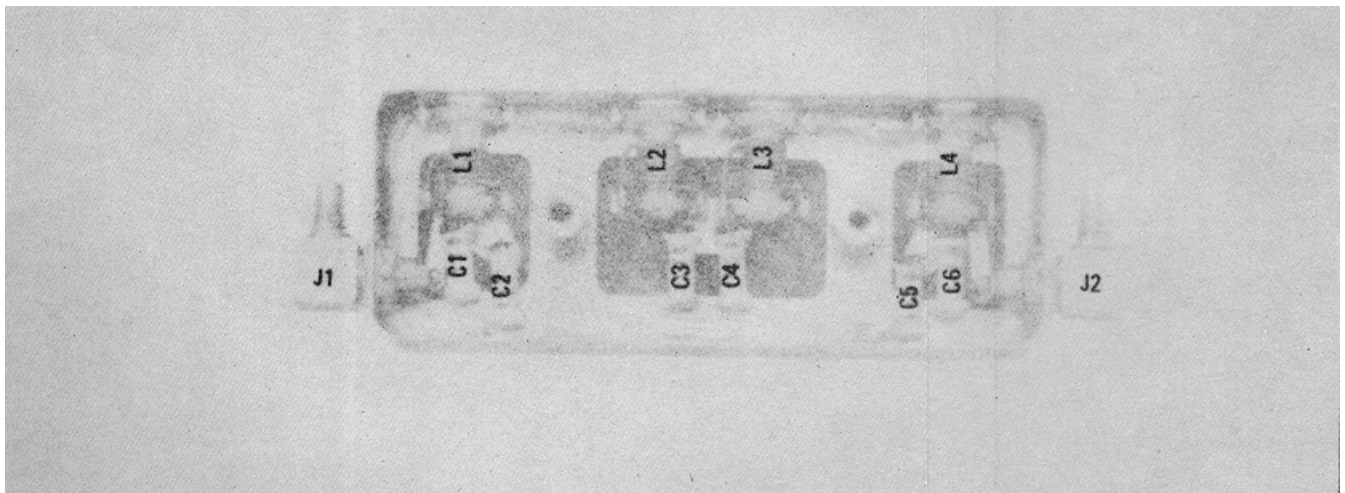
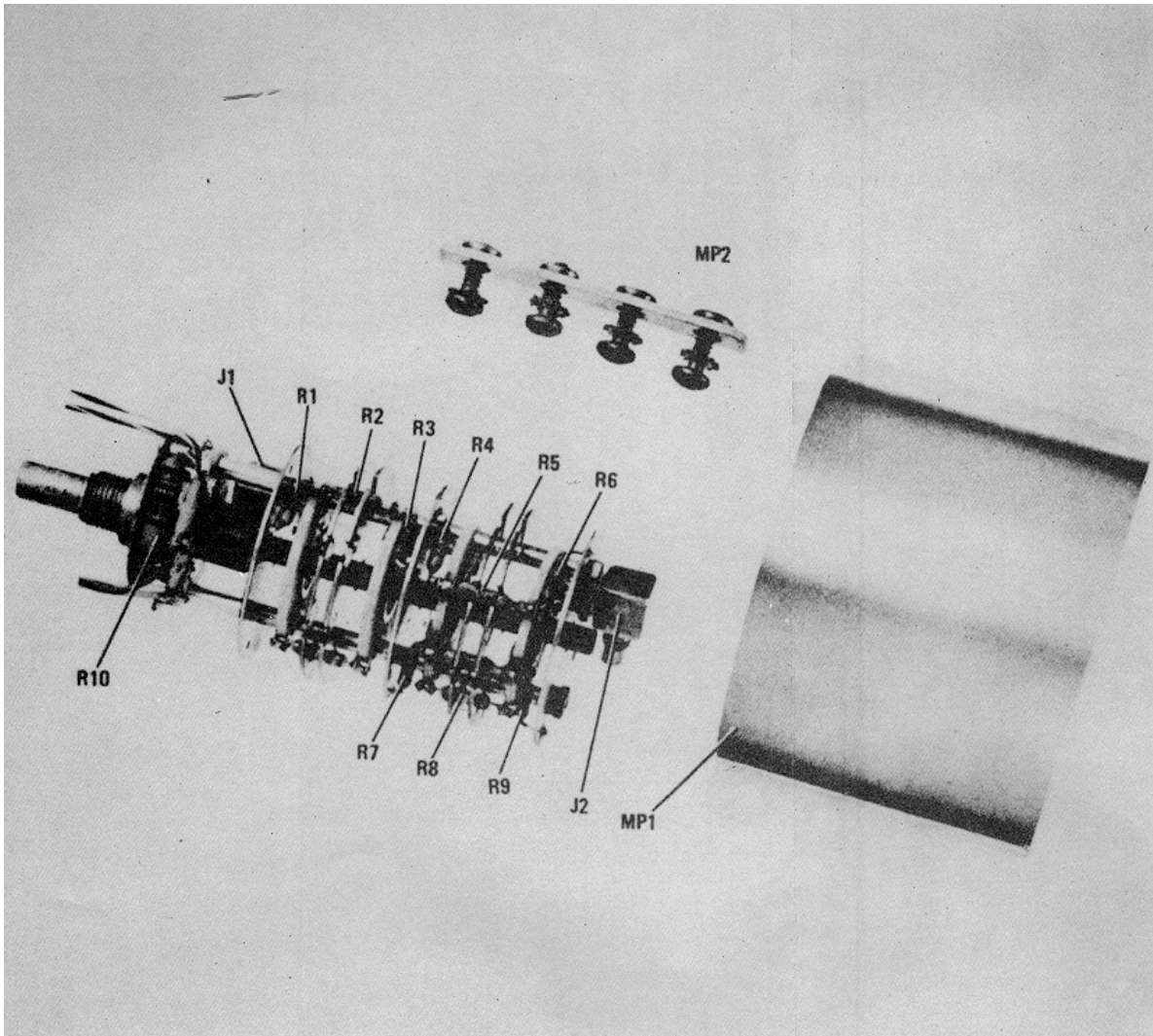

Figure 8-25. 120 MHz Low Pass Filter A11 (08553-6001) Component Locations

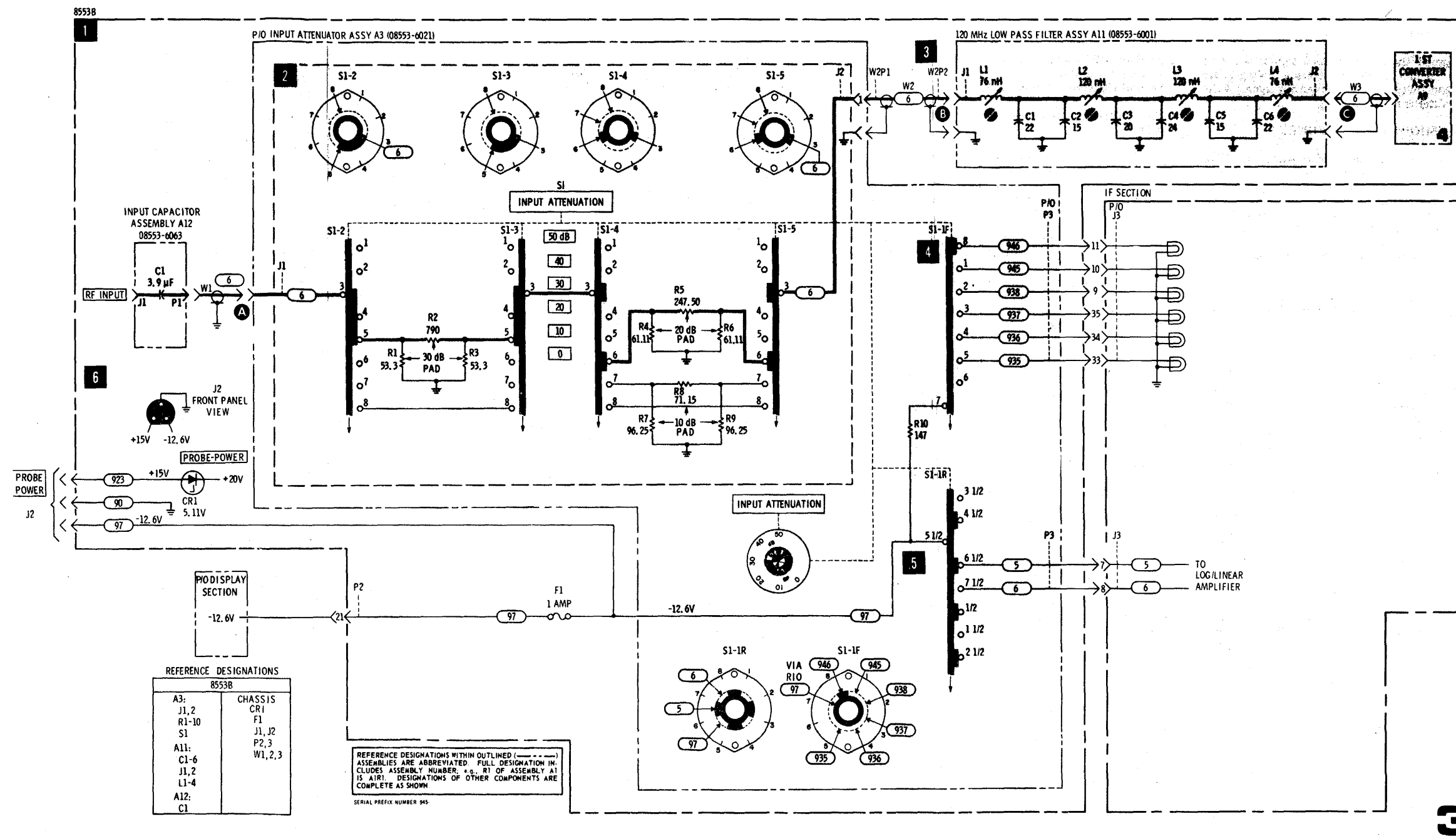

Figure 8-26. RF Input, Attenuator Control and 120 MHz Low Pass Filter

SERVICE SHEET 4

It is assumed that the rf input signal, the first oscillator signal, and dc operating voltages are present, and that the 200 MHz output signal of the bandpass filter is low or missing.

TROUBLESHOOTING PROCEDURE

When trouble has been isolated to the 200 MHz IF assembly it should be removed from the casting and installed in an inverted position using the fasteners provided in the Service Kit to provide easy access to all components or major sub-assemblies. Both the first mixer and the 200 MHz Filter are sealed units; repairs are possible, but are not considered to be practical due to component matching and positioning requirements.

NOTE: If repairs are required the adjustments specified in Paragraph 5-24 of Section V should be performed.

EQUIPMENT REQUIRED

Service Kit	HP 11592A
VHF Signal Generator	HP 608F
50-Ohm Termination.....	HP 11593A
Vector Voltmeter.....	HP 8405A
Cable Assembly	HP 10501A
BNC Tee	UG 274 B/U

CONTROL SETTINGS

INPUT ATTENUATION	0 dB
TUNING STABILIZER	ON
SCAN WIDTH	PER DIVISION
FREQUENCY.....	30 MHz
BANDWIDTH	300 kHz
SCAN WIDTH PER DIVISION	20 kHz

1. 200 MHz IF ASSEMBLY A9 (General)

The mixer section of the 200 MHz IF assembly mixes the rf input signal from the 120 MHz low pass filter with the first local oscillator signal to

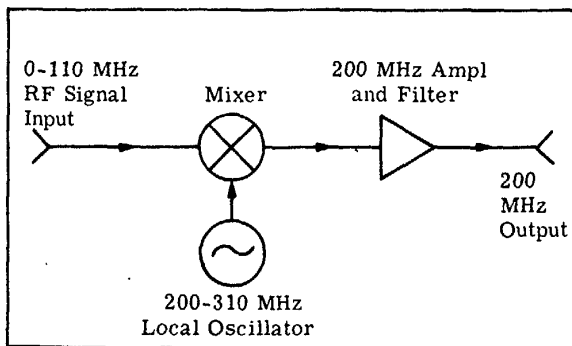

Figure 8-27. Functional Block Diagram.

produce a 200 MHz IF signal. This signal is amplified and filtered prior to being applied to the Second Converter Assembly A10.

The following components are factory selected values:

C2 in the A9A2 sub-assembly is selected to optimize mixer flatness.

C8 in the A9A1 amplifier adjusts the IF amplifier gain to 14 dB.

R7 in the A9A1 amplifier is selected, for maximum flatness of the bandpass filter.

The value of these components is not extremely critical. They are selected at time of final assembly and test to ensure optimum compatibility with associated components.

2. FIRST CONVERTER SUB-ASSEMBLY

The first converter is a double-balanced mixer driven by a 1V rms (200 to 310 MHz) signal from the first local oscillator. This signal, applied to the mixer by the secondary of T2, drives the diodes of two adjacent arms of the bridge alternately into conduction. As the diodes conduct, the rf input signal voltage is induced in the secondary of T3, with its polarity changed at the rate of the local oscillator frequency. This results in a suppressed local oscillator signal with sidebands at plus and minus the rf input signal frequency. The 200 MHz IF amplifier then selects and amplifies the lower frequency sidebands. CR1 and CR2 limit rf input signals to protect the mixer quad from burn-out. C1 and C2 insure maximum flatness near 100 MHz. Transformers T1 and T4 are baluns. T1 balances the first local oscillator signal about ground, T4 unbalances the mixer output with respect to ground.

TEST PROCEDURE

Since signals other than the desired 200 MHz IF are present at the output of the mixer it is impractical to attempt evaluation of circuit performance by monitoring the mixer output directly with the Vector Voltmeter. A simple but conclusive test which will isolate signal loss to a defective first mixer may be conducted as follows: Set the analyzer controls to display the first local oscillator feedthrough signal. SCAN WIDTH PER DIVISION -10 kHz; BANDWIDTH -3 kHz; FREQUENCY -0 MHz. The signal displayed on the analyzer CRT should be about -25 dBm. If the signal observed is -15 dBm or greater the mixer is damaged (unbalanced) and repair or replacement is

←**SERVICE SHEET 3.**

RF Input, Attenuator Control & 120 MHz Low Pass Filter

required. If the signal is low or missing proceed to step 1 and if necessary, step 4. If the trouble is found and remedied in step 3 and/or step 2 repeat steps to verify proper mixer operation.

MIXER DIODE REPLACEMENT

The mixer diode, A9A2 CR 3, 4, 5 and 6 can be replaced if a certain amount of care is exercised. The following tips should be followed when replacing the diodes to avoid damage to the new diodes. Refer to Figure 8-29, Service Sheet 4, for component identification and location.

1. Remove the A9A2 1st Mixer Assy, HP Part No. 08553-6002 from the A9 200 MHz IF Assembly.
2. Remove the bottom cover of the mixer assy and remove CR3, CR4, CR5, and CR6 using a 231/2 watt soldering iron. Note the polarity and positioning of each diode as it is removed.
3. Clean the vacated holes in the printed circuit board using a solder puller.
4. The replacement diodes are contained in a matched set of four, HP Part No. 10514-8454. Pre-form each diode to fit the printed circuit board spacing; trim off any excess lead length.
5. Again, using a 231/2 watt soldering iron and heat sink, apply heat and solder as quickly as possible to secure each diode in place.
6. Remove excess rosin from the printed circuit board and replace the mixer cover.
7. Return the mixer assembly to the A9 board. Install the A9 assembly in the 8553B.
8. Check the operation of the 1st mixer per step 2.

3. 200 MHz IF AMPLIFIER

Q1 and Q2 are common-emitter cascaded amplifiers employing collector to base feedback. CR1 and CR2 determine quiescent collector voltage. C2 and C7 bypass the zener diodes to provide a signal feedback path. L2 and L5 are used to peak stage gain and for parasitic suppression. C8 adjusts the overall gain of Q1/Q2 to 14 dB. The 230 MH tuned trap consisting of L8 and C10 in the Q collector circuit prevents possible residual responses due to harmonic mixing of the first and second local oscillator signals. The 100 MHz tuned trap consisting of C13 and L10 in the Q1 base circuit prevents low frequency residual responses due to high frequency signals at the input.

TEST PROCEDURE

Disconnect the first mixer assembly and connect a 200 MHz, -17 dBm signal from the HP 608F to the input of the IF amplifier. Connect the HP 8405A to TP B (input to the 200 MHz filter). A reading of approximately -3 dBm should be observed. If the correct signal level is present proceed to step 4. If not, check Q1/Q2 and associated components. The signal level at TP D should be approximately -10 dBm.

4. 200 MHz BANDPASS FILTER

The 200 MHz Bandpass Filter is a passive filter consisting of three coils wound on a common form; separate input and output coils, and switch capacitors. Three of the capacitors, C3, C5 and C6 are adjusted for maximum flatness at 200 MHz ±2 MHz.

TEST PROCEDURE

With the -3 dBm signal specified in step 3 applied to the input of the bandpass filter, connect the HP 8405A to the output of the bandpass filter TP C (this output is available at the center conductor of a feedthrough capacitor that is not used for coupling purposes). The reading observed should be approximately -6 dBm. If the correct signal is obtained the IF assembly is serviceable. If the signal observed is not correct, repair or replace the 200 MHz Bandpass Filter.

Simplified Test Procedure Tree

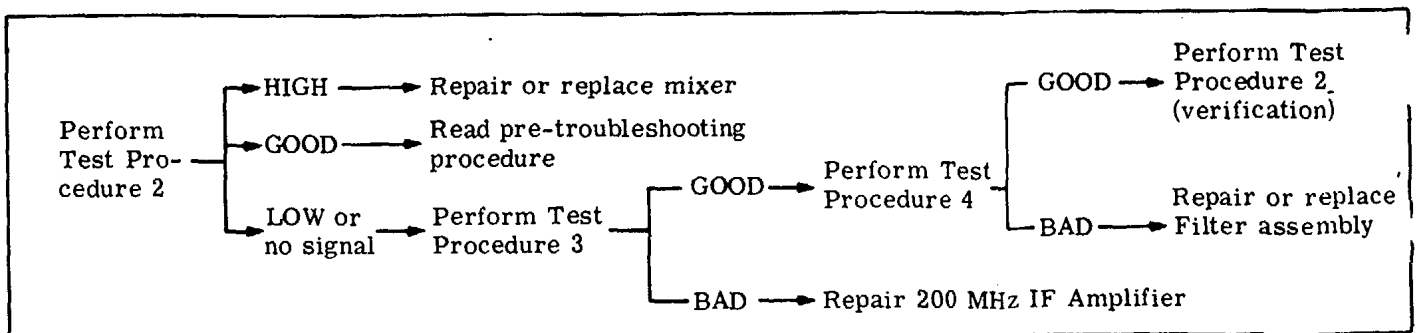

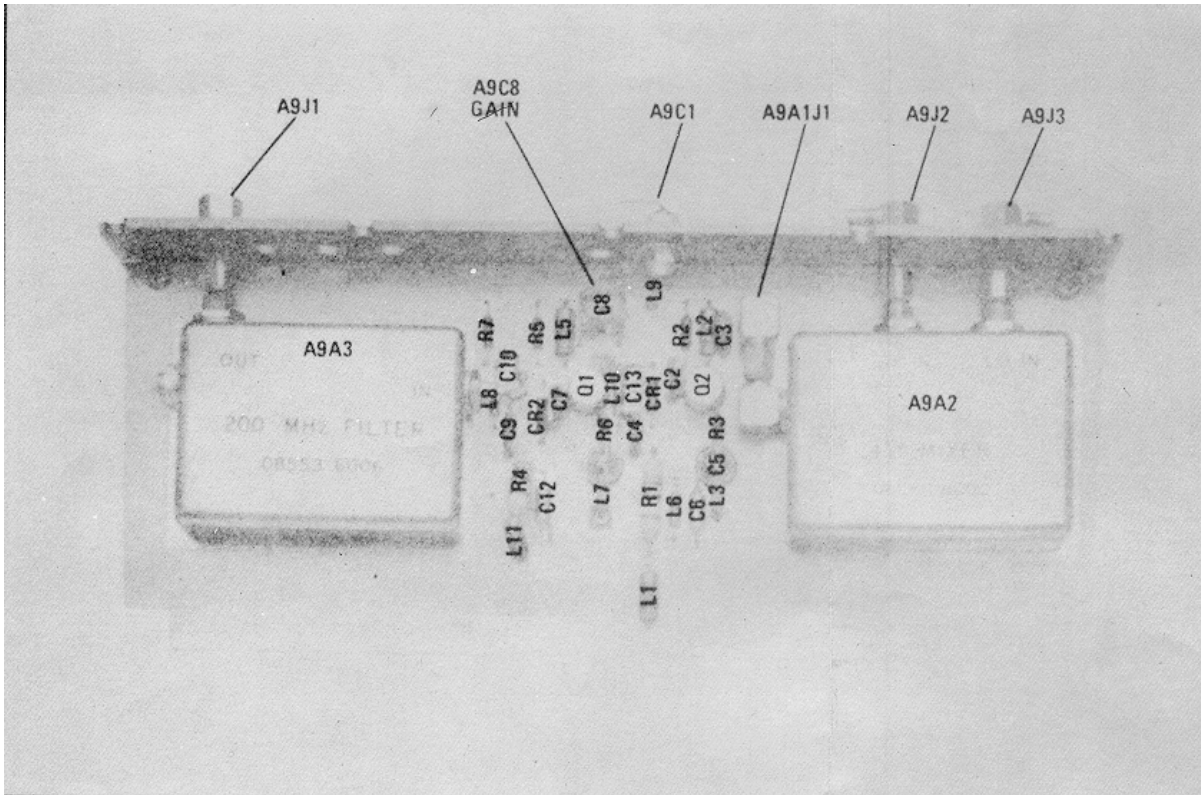

Figure 8-28. 200 MHz IF Assembly A9 (08553-6004) Component, Connections and Adjustment Locations

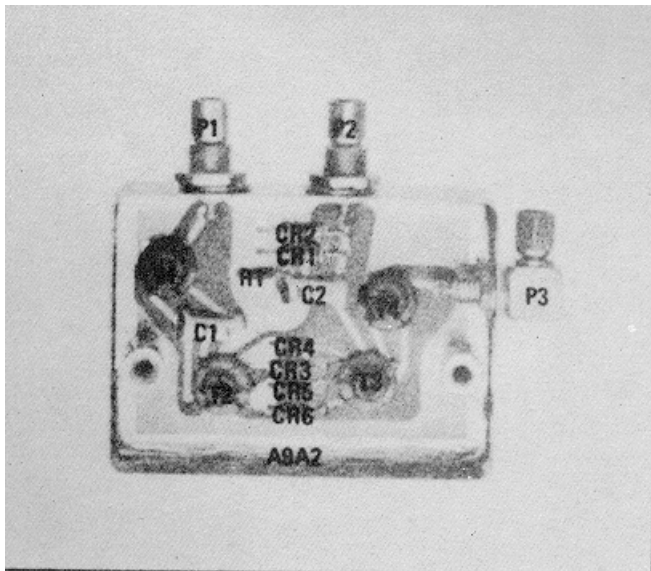

Figure 8-29. A9A2 (08553-6002) Components Locations

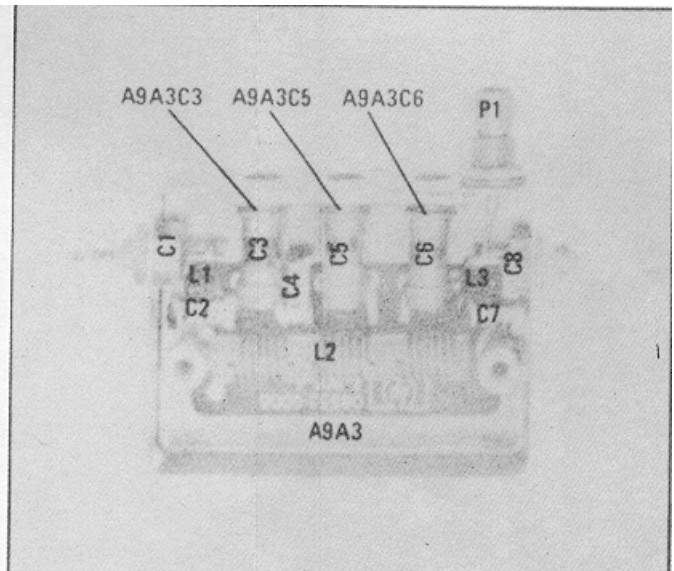

Figure 8-30. A9A3 (08553-6006) Component Locations

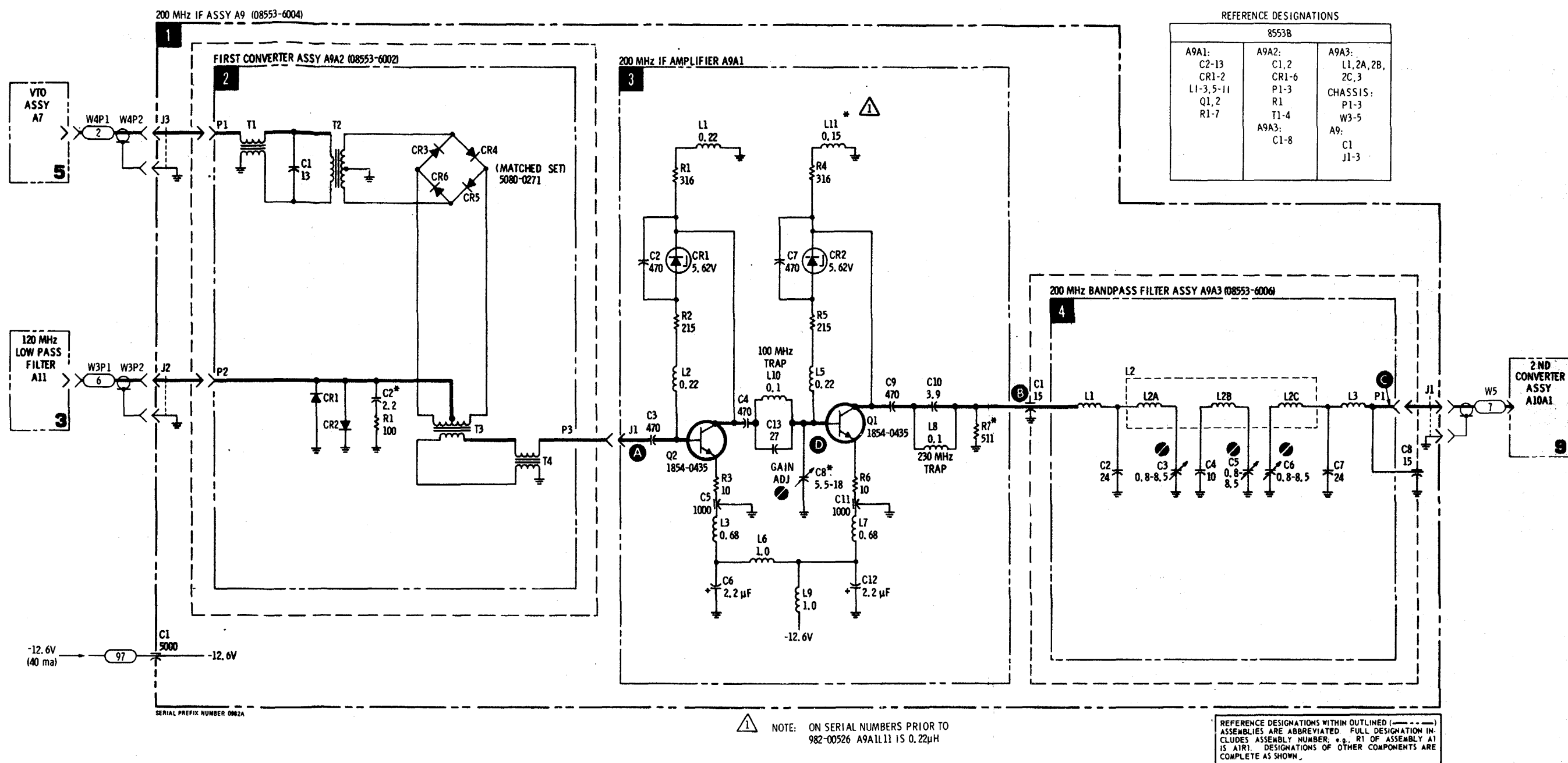

Figure 8-31. First Converter and 200 MHz IF Amplifier
8-31

SERVICE SHEET 5

It is assumed that the tuning ramp voltage from Voltage Control Assembly A5 and dc operating voltages are present and correct and that one or more of the output signals is missing or out of tolerance.

TROUBLESHOOTING PROCEDURE

When trouble has been isolated to the Voltage Tuned Oscillator Assembly, the assembly should be removed from the casting and reinstalled in an inverted position to provide easy access to all components. Troubleshooting information follows the technical discussions of individual circuits.

It is suggested that the output levels specified in Step 3 Test Procedure, Table 1, be checked first. If any of the output levels are as specified, trouble may be in one or more of the buffer amplifiers, and steps 1 and 2 need not be performed.

EQUIPMENT REQUIRED

- Vector Voltmeter HP 8405A
- VHF Signal Generator HP 608F
- Service Kit HP 11592A

CONTROL SETTINGS:

(Unless otherwise specified in individual tests).

- SCAN WIDTH ZERO
- TUNING STABILIZER On
- SCAN WIDTH PER DIVISION 20 kHz
- FREQUENCY 0 MHz

200-310 MHz VOLTAGE TUNED OSCILLATOR ASSEMBLY (General)

The first local oscillator is a voltage tuned oscillator which, when operated in the swept mode, provides an output of 200 to 310 MHz or selected frequencies between these two limits. The output of the oscillator is amplified and fed to three outputs through individual buffer amplifiers. In narrow scan widths the local oscillator is not swept and when the analyzer is operated with the TUNING STABILIZER on the first local oscillator output is sampled in the APC assembly by pulses developed from the 100 kHz reference signal. These samples are used to develop an error voltage which is processed in the Voltage Control Assembly to phase lock the first local oscillator.

The following components are factory selected values:

- R2 is selected to provide the proper adjustment range of R3.
- R17 is selected to optimize the VTO output flatness.

- R19 is selected to provide the proper output level to the rear panel output jack.
- R28 is selected to compensate for differences in tank circuit components.

The three major circuits of the VTO Assembly (Oscillator, Power Amplifier, and Buffer Amplifiers) are discussed separately in steps, 1, 2 and 3.

4. FIRST LOCAL OSCILLATOR

The principal resonant tank circuit components consist of L4, L5, and C6. The capacity of C6, which determines the frequency at which oscillation occurs, is controlled by a voltage ramp supplied from the Voltage Control Assembly.

The 180 degree phase shift across the resonant tank circuit is complemented by a 180 degree phase shift across the oscillator Q2/Q3. This is accomplished by operating Q2 and Q3 past their beta cut-off frequencies to provide an apparent phase shift of 90 degrees per stage. (Actually, the phase shift is 270 degrees per stage, but the end result is the same.) Operating the transistors in this mode maintains a relatively constant output level across the operational range of 200 to 310 MHz. CR1 and CR2 limit the input to Q3 which operates as a class B amplifier.

TEST PROCEDURE

If none of the signal levels specified in step 3 Table 1, are obtained, failure of the first local oscillator may be verified by injecting a signal into the emitter circuit (TP D) of the Power Amplifier Q4.

The input from the Voltage Control Assembly should be disconnected and a signal injected at TP D (Q4-e) from the HP 608F Signal Generator. Any frequency between 200 and 310 MHz may be used. Use the HP 8405A to verify the presence or absence of signals at J1, J3 and J4. (The signal levels for this test are unimportant and will vary with output from the signal generator.) If the output signals are not present, proceed to step.2.

If the output signals are present with an input applied to TP D, check Q2, Q3 and associated components.

2. POWER AMPLIFIER

Power Amplifier Q4 is a grounded base amplifier. C13 peaks the gain of the amplifier at the first local oscillator frequencies, prevents the stage from oscillating, and by-passes high order harmonics.

←SERVICE SHEET 4
First Converter and 200 MHz IF Amplifier.

The output of the power amplifier is coupled through center tapped transformer T3 and center tapped transformer T2 to the buffer amplifiers. T2 and T3 are not inductively coupled.

TEST PROCEDURE

Connect the output of the HP 608F (any frequency between 200-310 MHz) to the Q4 collector side of T3 (TP E) and use the HP 8405A to check signal levels at J1 (TP C), J3 (TP A), and J4 (TP B). If the signals are present, Q4 or associated components may be defective. If signals are not present inject the signal at TP F (T2) and check for the presence of the signal at TP A and TP B. If output signals are still not present, proceed to step 3. If signals are present with the input to TP F, check T3 and T2.

3. BUFFER AMPLIFIERS

Q1, Q5, and Q6 are buffer amplifiers which function to isolate the outputs from the oscillator and power amplifier, and from each other. T2 splits the output signal from the power amplifier and also prevents reflected signals from the first mixer and APC circuits from interfering with signal processing. Q1, a common base amplifier, supplies the APC assembly with a sample of the first local oscillator output to be used for phase locking purposes. This signal is coupled out through a 320 MHz Low Pass Filter and center tapped transformer T4. T4 and associated components ensure an approximate 50-ohm output impedance and a smooth sine wave. Common base amplifier Q5 provides the first local oscillator monitor signal and

provides the input to the mixer buffer stage through center tapped transformer T1. Common emitter amplifier Q6 provides a 1V rms (typical) signal to drive the double balanced bridge mixer in the 200 MHz IF assembly.

TEST PROCEDURE

With the analyzer operating in ZERO scan mode and tuned to 0 MHz, check for the presence of typical signal levels specified in Table 1 below using the HP 8405A Vector Voltmeter.

Table 1

J1	J4	J3
640 mV rms	1V rms	-6 dBm

NOTE: The HP 8405A Channel A probe should be used first to measure the signal at J3 and should remain connected to maintain meter phase lock.

The readings at J1 and J4 should be taken with the HP 8405A Channel B.

If none of the specified signals are present, perform step 1 and if required, step 2.

If an output is observed at J1 and J3 but not at Q6 or associated components may be defective.

If an output is observed at J3 and J4 but not at J1, Q1, the Low Pass Filter, or associated components may be defective.

If an output is present at J1 but not at J3, or J4, Q5 or associated components may be defective.

Simplified Test Procedure Tree

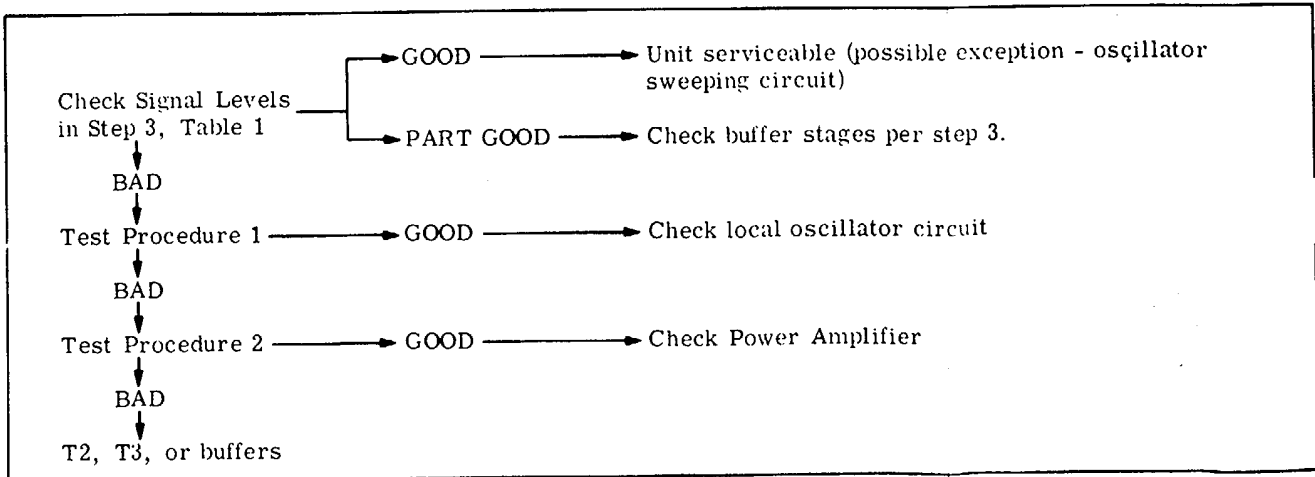

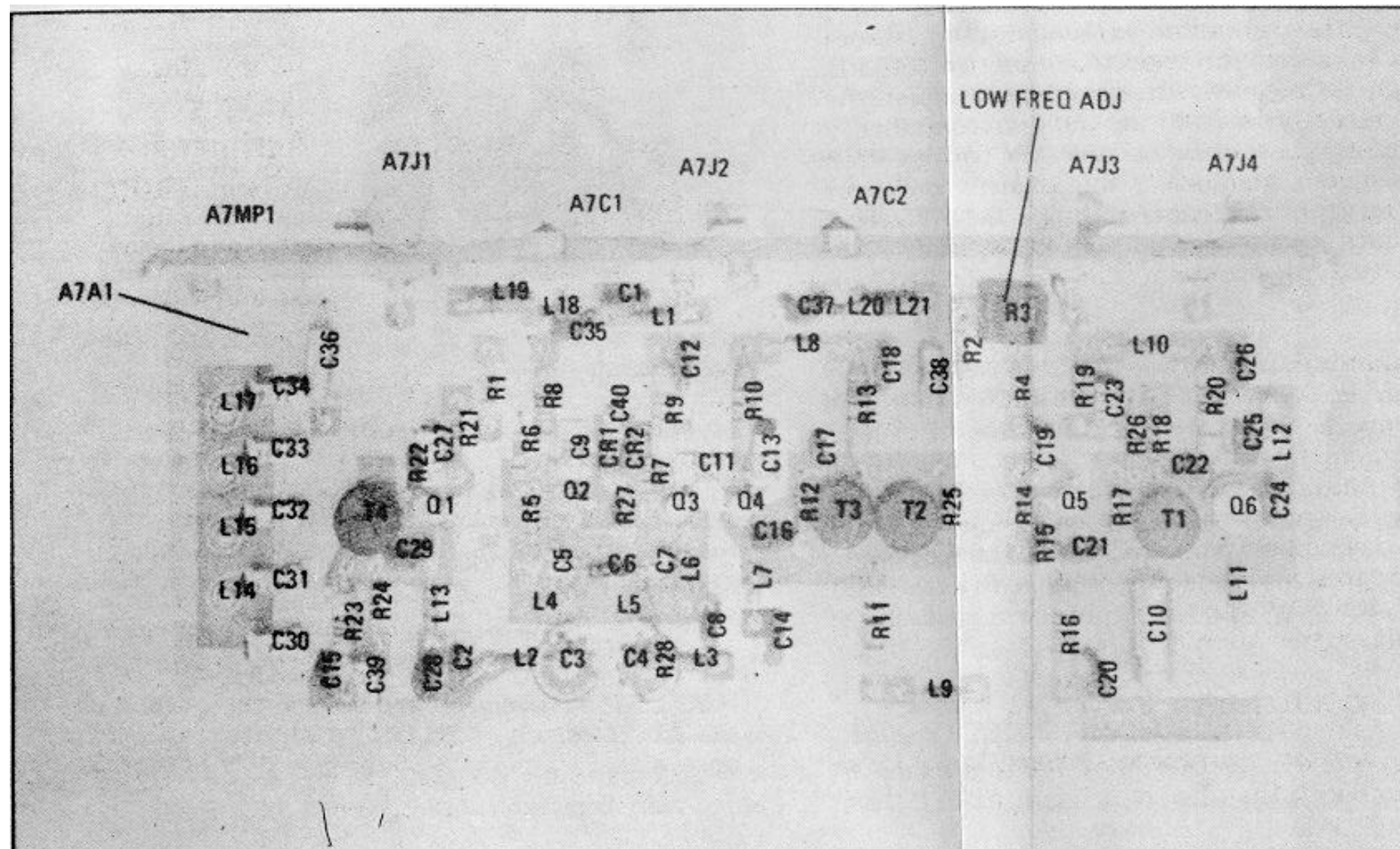

Figure 8-32. 200-310 MHz VTO Assembly A7 (08553-6003) Component Locations

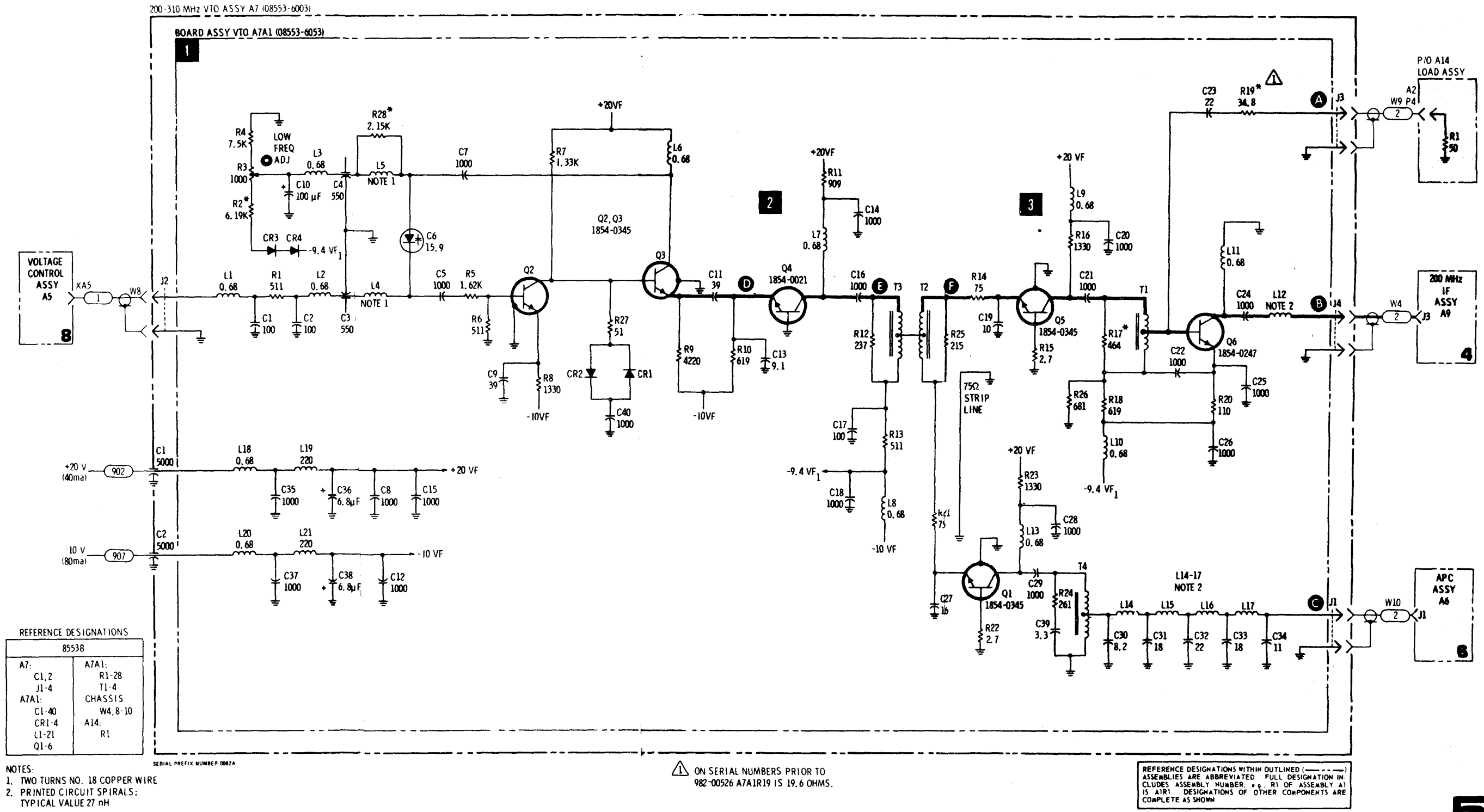

Figure 8-33. 200-310 MHz Voltage Tuned Oscillator

When this condition exists the output of the sampler is random and the search oscillator-amplifier oscillates at approximately 10 Hz. The output of the search oscillator, amplifier, under these conditions, causes the voltage control assembly to sweep the first local oscillator approximately ± 75 kHz.

As the first local oscillator is swept through one of the 100 kHz calibration harmonics, the first local oscillator output correlates to consecutive 100 kHz pulses from the pulse generator in the sampler gate. Approximately five 100 kHz pulses are required to accomplish phase lock. As the APC voltage from the sampler stabilizes, the search oscillator amplifier stops oscillating and only the APC signal is coupled to the voltage control assembly as an error signal to maintain the phase locked condition.

A second output is provided by the APC assembly through the TUNING STABILIZER switch and Reference Assembly A8 to control the third local oscillator in the IF section. This signal acts as an offset voltage to shift the 47 MHz oscillator frequency to compensate for the frequency shift required to phase lock the first local oscillator. This compensation is required to maintain the CRT display accuracy when switching from unstabilized to stabilized operation.

TEST PROCEDURE

Connect the HP 180A/1801A/1821A Channel A input to TP 3, the Channel B input to TP D, and observe the waveform.

NOTE:

The APC output must be disconnected from C1 to prevent the first local oscillator from being phase locked or these signals cannot be observed.

CONTROL SETTINGS:

Oscilloscope:

Chan. A:
0.5V/Div
Chan. B:
0.05 V/Div
20 msec/Div
10:1 probes
MAGNIFIER X1

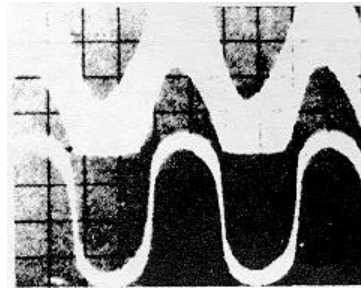

Waveform GOOD and verification procedure below also satisfactory, assembly is functioning properly.

Waveform BAD: Check Q1/Q2/Q3 and associated components.

To verify proper operation of this circuit momentarily place the TUNING STABILIZER switch to OFF. The Channel B waveform should disappear while the switch is off. Next, reconnect the APC output lead to C1 and note that both waveforms disappear as the first local oscillator becomes phase locked.

NOTE:

When repairs are required to any portion of the APC assembly, it should be adjusted in accordance with Paragraphs 5-28 through 5-31 of Sect. V.

Simplified Test Procedure Tree

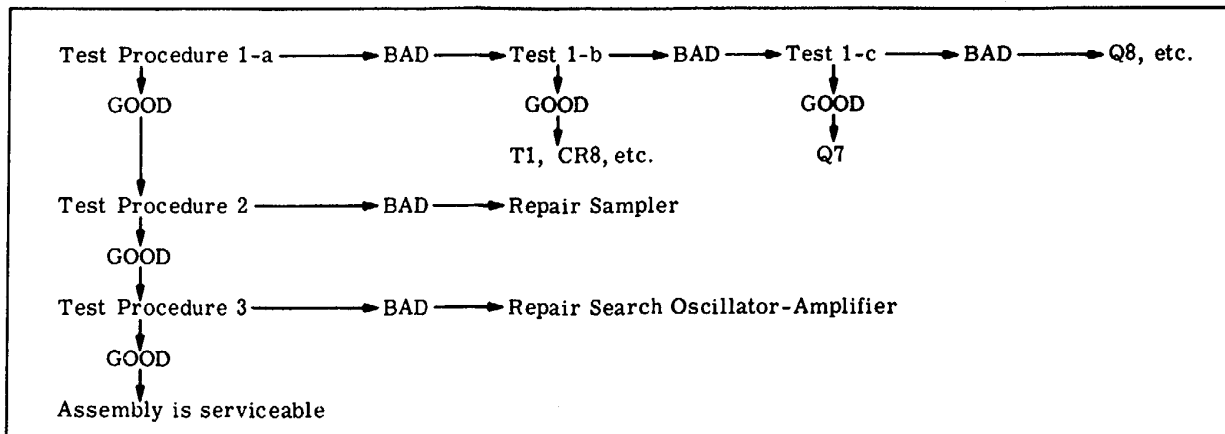

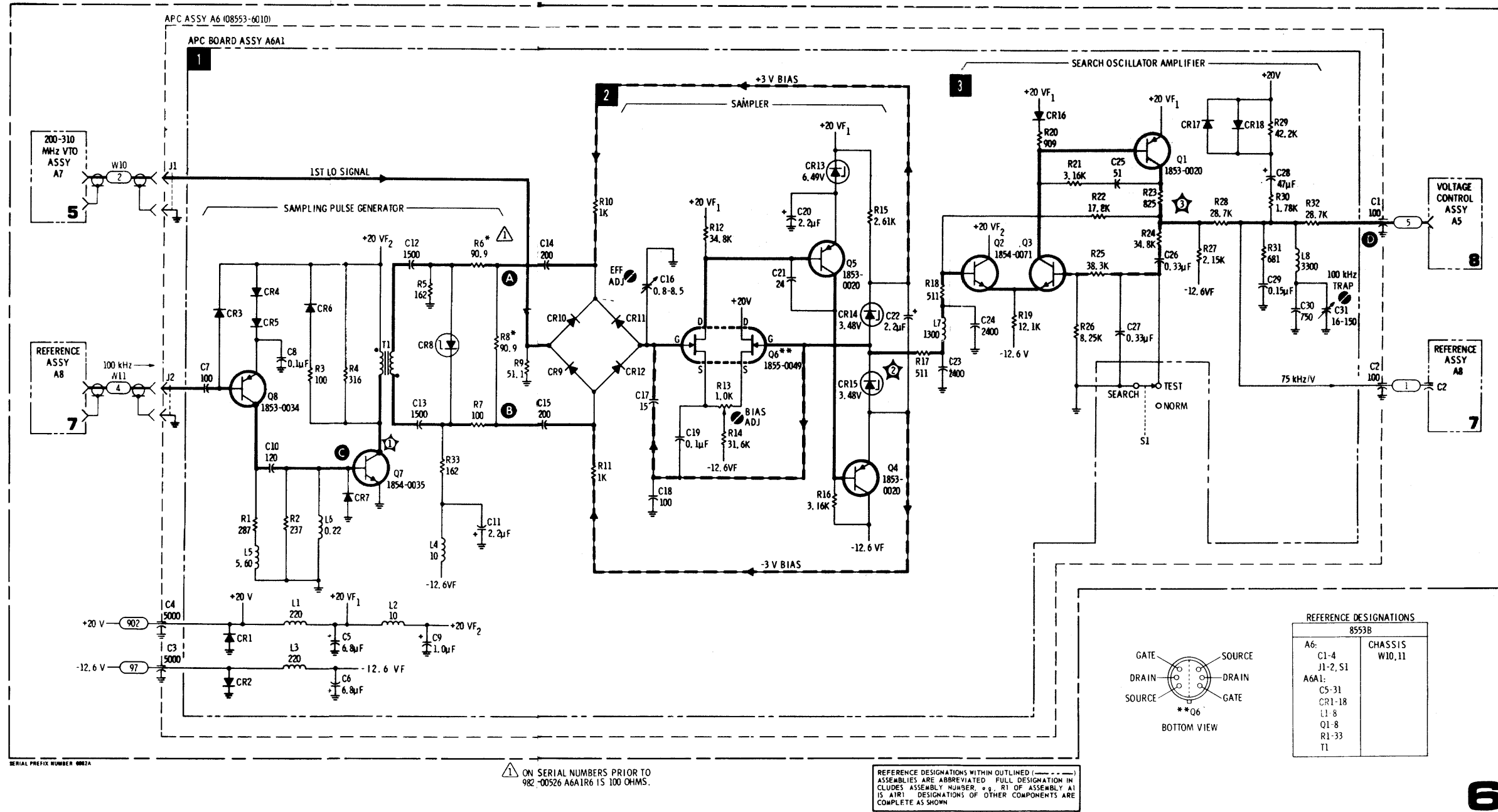

Figure 8-36. Automatic Phase Control and Sampler/Amplifier Circuits

and provides a 6 volt peak-to-peak square wave output at 100 kHz. This signal is applied to the APC assembly (A6) where it is processed to provide phase lock and frequency control signals.

TEST PROCEDURE:

Connect the HP 180A/1801A/1821A to TP A (J1) and observe the waveform.

CONTROL SETTINGS:

Oscilloscope:

1 μ/sec/Div

0.2 V/Div

10:1 probe

Waveform GOOD: Assembly functions properly

Waveform BAD: Check Q8/Q9 and associated components

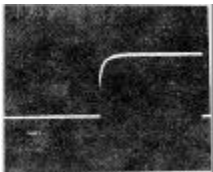

5

APC COMPENSATION CIRCUIT

The input APC signal is grounded through the scan width attenuator switch in scan widths of .05 MHz or greater regardless of the position of the TUNING STABILIZER switch. In scan widths of 20 kHz or less the APC signal is grounded only when the TUNING STABILIZER is in the OFF position.

When the SCAN WIDTH PER DIVISION switch is set to 20 kHz or less, the TUNING STABILIZER switch OFF and the SCAN WIDTH set to PER DIVISION, a ground is applied to the junction of R33 and R34 which eliminates the +20 volts applied to the circuit through R33 and allows C21 to discharge through R35. Approximately 0.5 second after phase lock is initiated, C21 discharges to a level which will allow Q14 to conduct. When turned on, Q14 turns off Q13 and causes relay K1 to deenergize. Relay K1 remains deenergized as long as the analyzer is in a stabilized mode.

During the 0.5 second time that relay K1 is energized after initiation of the phase-lock cycle, the APC signal is processed by operational amplifier Q10/Q11/Q12 and applied to C23, which charges to the dc level of the signal. When relay K1 opens, C23 cannot discharge because of the high input impedance of Q1. The output of Q1 is clamped at a level determined by the level of the charge on C23 and is applied as an offset voltage to the third local oscillator to compensate for frequency shift required to phase lock the first local oscillator.

When the TUNING STABILIZER is turned OFF the system is no longer phase locked. Relay K1 energizes, allows C23 to discharge, which removes the offset

voltage from the 47 MHz local oscillator summing amplifier.

TEST PROCEDURE

Normally the APC compensation circuit will require service only if the IF section 47 MHz Oscillator is not operating properly. Using the HP 6215A Power Supply to inject a simulated input as outlined in the chart below and taking voltage measurements with the HP 3440A/3443A should help to isolate the cause of malfunction to a circuit or component.

TP	E	GROUNDED		+2 VDC		-2 VDC	
		ON	OFF	ON	OFF	ON	OFF
Q10	E	-1.7	-1.7	+1.5	+1.5	-2	-2
	B	-1.2	-1.2	+2	+2	-2	-2
	C	+19.8	+19.8	+19.2	+19.2	+19.8	+19.8
Q11	E	-1.7	-1.7	+1.5	+1.5	-2	-2
	B	-1.2	-1.2	+2	+2	-1.5	-1.5
	C	+19.9	+19.9	+19.9	+19.9	-19.9	+19.9
Q12	E	+19.9	+19.9	+19.9	+19.9	+19.9	-19.9
	B	+19.8	+19.8	+19.2	+19.3	+19.8	-19.8
	C	-12.4	-12.4	+9.5	+9.2	-12.4	-12.3
Q13	E	0	0	0	0	0	0
	B	-.1	-.7	-.1	-.7	-.1	-.1
	C	-12.4	-.1	-12.4	-.1	-.7	-.7
Q14	E	0	0	0	0	0	0
	B	-.6	+.4	-.6	+.4	-.6	+.4
	C	-.1	-.7	-.1	-.7	-.1	-.7
Q1		*	*	*	*	*	*
Gate		-12.3	-12.3	+2.3	+2.3	-12.3	-12.3
Drain		-12.4	-12.4	-12.4	-12.4	-12.4	-12.3
Source		-4.6	-4.6	+7.8	+7.8	5.6	-5.6

*Discharges rapidly through test equipment (3440A/3443A)

Simplified Test Procedure Tree

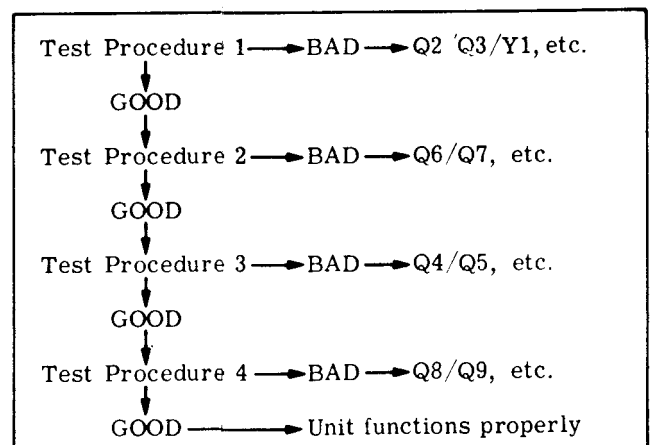

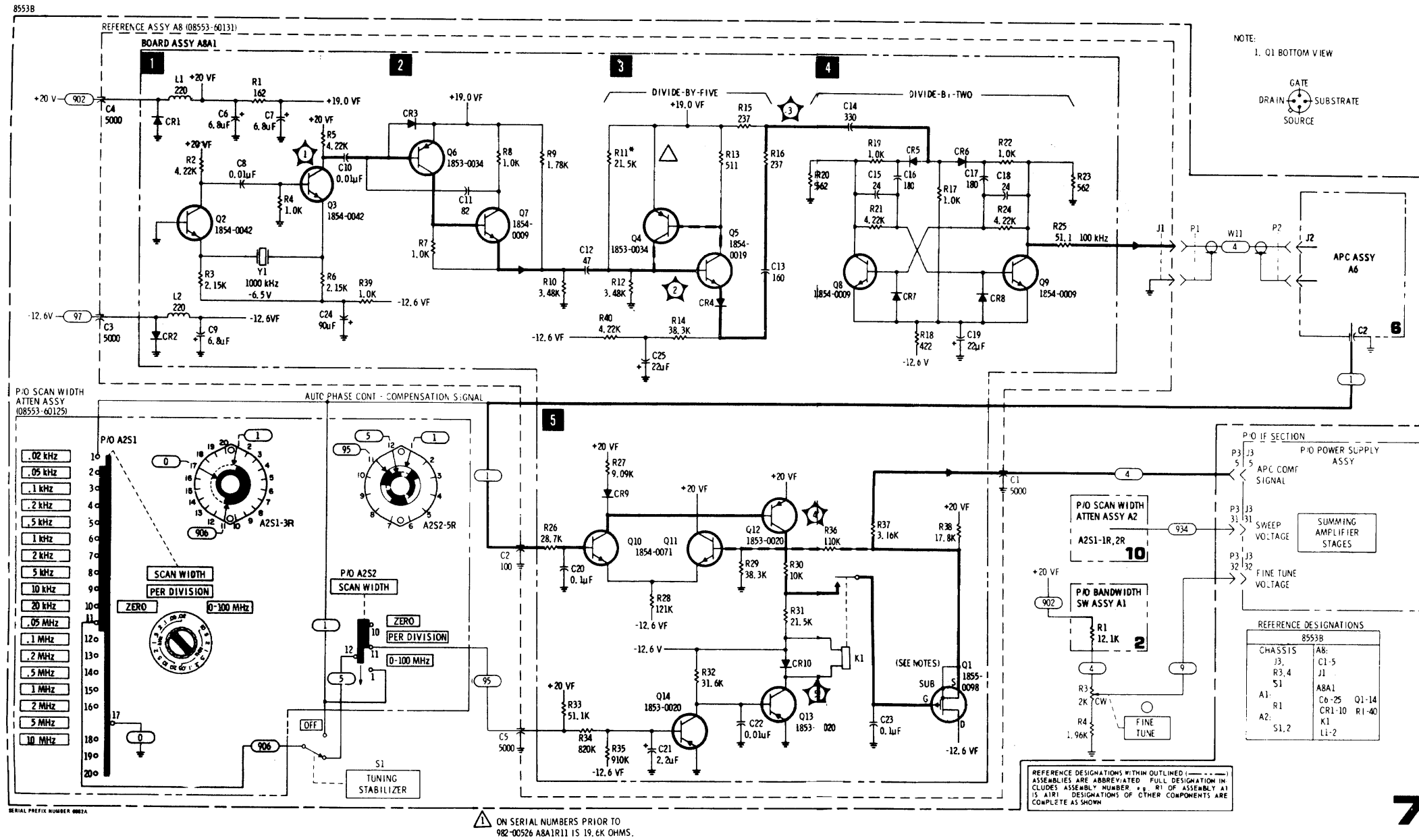

Figure 8-38. 1 MHz Crystal Oscillator, Frequency Divider and APC Compensation Circuits

shaping is accomplished by a bias network in the base circuit of Q4B. The response time of the operational amplifier is determined by C9 and R23.

TEST PROCEDURES

2-a. Connect Oscilloscope to Test Point D and observe waveform of 1-c.

CONTROL SETTINGS: Same as 1-a.

Waveform same as 1-c. GOOD: Proceed to step 2-b.
BAD: Check wiring and S2-5F of SCAN WIDTH switch.

2-b. Connect Oscilloscope to Test Point E and observe

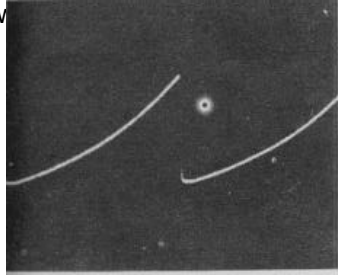

Oscilloscope:
1 msec/Div
1 V/Div
10:1 probe

Analyzer:
10 MHz/Div
5 msec/Div
50 MHz **4** FREQ.

Waveform GOOD: Proceed to step 3.
Waveform BAD: Check Q2/**3**/Q4 circuits. If trouble is not located proceed to step 3.

3 SHAPING NETWORK

Voltage regulation for the shaping network, consisting of resistors R32 through R66, is provided by Q1. Diodes CR10 through CR21 are sequentially forward biased as the ramp voltage at the base of Q4 in the shaping amplifier increases. As each diode is forward biased it places additional resistive networks in parallel to reduce the total resistance of the network. When the first local oscillator is being swept from 200 to 310 MHz the ramp voltage is controlled by the shaping network to provide the exponential voltage ramp output required to linearly control the first local oscillator frequency. Resistors marked with an asterisk are factory selected values.

TEST PROCEDURES

3-1. Measure voltage at the emitter of Q1. Should be +12.5V ±.1V.

Voltage GOOD: Proceed to 3-b.
Voltage BAD: Check Q1 circuit.

3-b. Check biasing network voltages in the following chart.

Diode	Frequency 0 MHz		Frequency 110 MHz	
	Cathode	Anode	Cathode	Anode
CR20	+12.53V	+70.2mV	+12.52V	+13.01V
CR19	+11.25V	+70.2mV	+11.42V	+11.91V
CR18	+ 9.97V	+70.2mV	+10.28V	+10.78V
CR17	+ 8.71V	+70.2mV	+ 9.11V	+ 9.62V
CR16	+ 7.44V	+70.2mV	+ 7.91V	+ 8.32V
CR15	+ 6.16V	+70.2mV	+ 6.66V	+ 7.18V
CR14	+ 4.89V	+70.2mV	+ 5.37V	+ 5.90V
CR13	+ 3.62V	+70.2mV	+ 4.05V	+ 4.58V
CR12	+ 2.34V	+70.2mV	+ 2.68V	+ 3.15V
CR11	+ 1.06V	+70.2mV	+ 1.29V	+ 1.80V
CR10	+404 mV	+69.8mV	+55.7mV	+ 1.05V
CR21	-642 mV	0V	-630mV	0V

After repairing the shaping network it should be calibrated in accordance with Paragraph 5-22 of Section 4. Recheck waveform Test Point E.

PRESET SCAN AMPLIFIER

The -5 volt to +5 volt ramp from the Scan Generator (A6) is applied to the base of Q1. The ramp is processed by Q1/Q2 and Q3 to provide a 0 to +12.9 volt ramp to the marker generator and the SCAN WIDTH switch. Offset adjust A4R7 is adjusted to calibrate the marker with respect to the FREQUENCY control.

TEST PROCEDURES

4-a. Connect Oscilloscope to Test Point F and observe waveform shown below:

CONTROL SETTINGS:

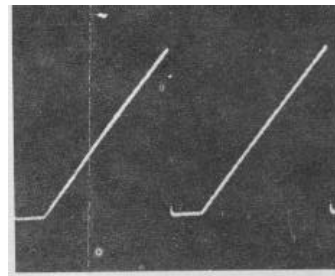

Oscilloscope:
5 msec/Div
0.2V/Div
10:1 probe

Analyzer:
SCAN WIDTH:
0-100 MHz
FREQUENCY:
50 MHz
SCAN TIME
2 msec/Div

Waveform GOOD: Proceed to step 4-b.
Waveform BAD: Input signal not correct or shorted Q1.

4-b. Connect Oscilloscope to Test Point G and observe waveform.

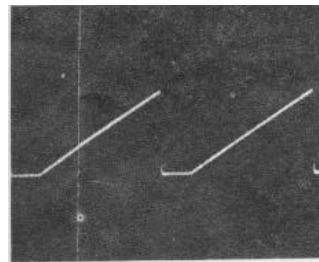

Oscilloscope:
5 msec/Div
0.5V/Div
10:1 probe

Analyzer:
Same as 4-a.

←SERVICE SHEET 7

1 MHz Crystal Oscil., Freq. Divider, & APC Compensation Circuit

SERVICE SHEET 6

It is assumed that inputs from the VTO and Reference assemblies and dc operating voltages are present and correct. It is further assumed that an attempt has been made to follow the procedures specified in paragraphs 5-28 through 5-31 of Section V without success.

TROUBLESHOOTING PROCEDURE

When trouble has been isolated to the APC assembly, the assembly may be removed from the casting and reinstalled in an inverted position using the fasteners supplied with the Service Kit to provide easy access to all circuit components. Troubleshooting information follows the technical description of the individual circuits.

NOTE

These circuits may be evaluated and repaired without an input rf signal applied to the analyzer. However, displaying the 30 MHz calibration signal on the analyzer display may be a definite aid in evaluating circuit performance.

EQUIPMENT REQUIRED

- Service Kit HP 11592A
- Volt-ohm-ammeter HP 410C
- Oscilloscope..... HP 180A/1801A/1821A
- Digital Voltmeter HP 3440A/3443A

CONTROL SETTINGS

(unless otherwise specified in individual tests.)

- SCAN WIDTH PER DIVISION 20 kHz
- INPUT ATTENUATION 0 dB
- SCAN WIDTH PER DIVISION
- BANDWIDTH 3 kHz
- FREQUENCY 30 MHz
- TUNING STABILIZER ON
- SCAN TIME PER DIVISION 1 msec
- LOG REF LEVEL -30 dBm
- LOG REF LEVEL VERNIER max ccw
- SCAN MODE INT
- VIDEO FILTER OFF
- SCAN TRIGGER AUTO

AUTOMATIC PHASE CONTROL SAMPLER/AMPLIFIER CIRCUITS (General).

Automatic phase control is initiated when SCAN WIDTHS of 20 kHz per division or less and TUNING STABILIZER functions are selected. The first local oscillator is phase locked (stabilized) to a harmonic of the 100 kHz reference oscillator. While the analyzer is phase locked each negative swing of the 100 kHz reference signal generates a pulse that samples the first local oscillator output signal. The sample is converted to

a dc error signal and fed back to the first local oscillator control circuit as a correction signal. When the TUNING STABILIZER is in the OFF position, the dc error voltage is grounded. Also, on scan widths greater than 20 kHz per division the dc error signal is grounded through the scan width attenuator circuit (see Service Sheet 7).

SAMPLER PULSE GENERATOR

A 100 kHz square wave signal derived from the 1 MHz crystal oscillator in the Reference Assembly A8 is applied to coupling capacitor C7. The negative-going portion of the square wave is differentiated by C7 to produce a negative spike at the base of Q8. The positive going portion of the square wave is clipped by CR3. When the negative spikes turn on Q8, the positive-going collector signal is differentiated by C10 and R2 and applied to the base of Q7 where negative portions of the signal are clipped by CR7. The negative-going signal at the collector of Q7 is applied to the primary of T1 to initiate sampler gate pulses by turning off step-recovery diode CR8.

Step-recovery diode CR8 is normally biased on. The 100 kHz pulses from Q7 are coupled through T1 to both ends of the step-recovery diode which is turned off for one nanosecond by each pulse. The resulting one nanosecond pulses are applied to both sides of the sampler diode quad to turn on all of the diodes simultaneously. Resistor R8 is a factory selected component which is selected at final test and assembly to ensure compatibility with the step-recovery diode and associated components.

TEST PROCEDURE:

1-a. Connect the HP 180A/1821A Channel A input to TP A, the Channel B input to TP B and observe the waveforms.

CONTROL SETTINGS:

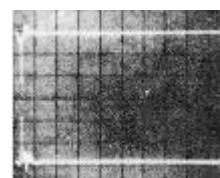

Oscilloscope:

0.1 μ/sec/Div

0.05 V/Div

10:1 probes

Waveform GOOD: proceed to **2**

Waveform BAD: proceed to 1-b.

1-b. Connect the HP 180A/1801A/1821A to TP 1 (Q7-c) and observe the waveform.

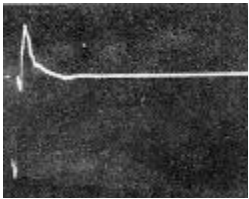

Oscilloscope:
 0.1 μ sec/Div
 0.5 V/Div
 10:1 probe

Waveform GOOD: Check T1, CR8 and associated components.

Waveform BAD: proceed to 1-c.

1-c. Connect the HP 180A/1801A/1821A to TP C (Q7-b) and observe the waveform.

CONTROL SETTINGS:

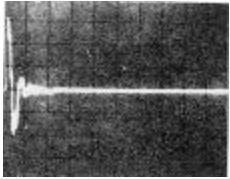

Oscilloscope:
 1 μ sec/Div

Channel A: 0.1 V/Div
 10:1 probe

Waveform GOOD: Check Q7

Waveform BAD: Check Q8 and associated components and repeat 1-a after completing repairs.

2 SAMPLER

Sampler gate diodes CR9 through CR12 are normally biased off by voltages applied through R10 and R11. During the one nanosecond off time of CR8, gating pulses from the pulse generator turn on CR9 through CR12 simultaneously. When the gate diodes are turned on, the voltage developed across R9 by the first local oscillator signal is coupled through to place a charge on C16 and C17. Since the sampler gate is conducting for only one nanosecond, C16 and C17 can charge only to approximately 15% of the dc level across R9. A feedback path from operational amplifier Q4/Q5/Q6 completes charging of C16 and C17 to 100% of the voltage level which appeared across R9 during the sampling period. Zener diodes CR14 and CR15 establish the bias voltage for the sampler gate diodes.

When the first local oscillator is operating at a frequency which is exactly harmonically related to the 100 kHz reference signal, the 100 kHz pulses from the pulse generator turn on the sampler gate diodes in time coincidence with the negative-going positive half cycles of the first local oscillator output signal. When the samples taken from the first local oscillator are taken at the same point on the negative-going signal each time the gate is opened, the voltage appearing across R9 is the same each time the gate is opened, and the charge on C16 and C17 remains constant. With these idealized conditions the output of the sampler to the search oscillator-amplifier would be a steady dc level at the junction of CR14 and CR15.

As the first local oscillator shifts in frequency the voltage developed across R9 is sampled at a different point on the signal slope. This results in a change in the level of the charge on C16 and C17 and a corresponding change in the sampler output to the search oscillator-amplifier.

TEST PROCEDURE:

Connect the HP 180A/1801A Channel A input to TP 1, the Channel B input to TP 2, and observe the waveform.

CONTROL SETTINGS:

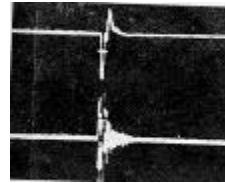

Oscilloscope:

Chan. A: 1V/Div
 Chan. B: 0.02V/Div
 2 μ sec/Div
 10:1 probes

Waveform GOOD: proceed to step **3**

If waveform for Channel B is not obtained, check diodes CR9 through CR12, Q4/Q5/Q6 and associated components.

To verify tuning stabilizer operation, place TUNING STABILIZER to OFF. Channel B signal becomes highly unstable, and the CRT display on the analyzer shifts.

1 SEARCH OSCILLATOR-AMPLIFIER

Transistors Q1/Q2/Q3 form an oscillator-amplifier whose operational state is determined by the sampler circuit output. When the analyzer is not phase locked there is no correlation between consecutive 100 kHz pulses from the pulse generator and the signal being received from the first local oscillator.

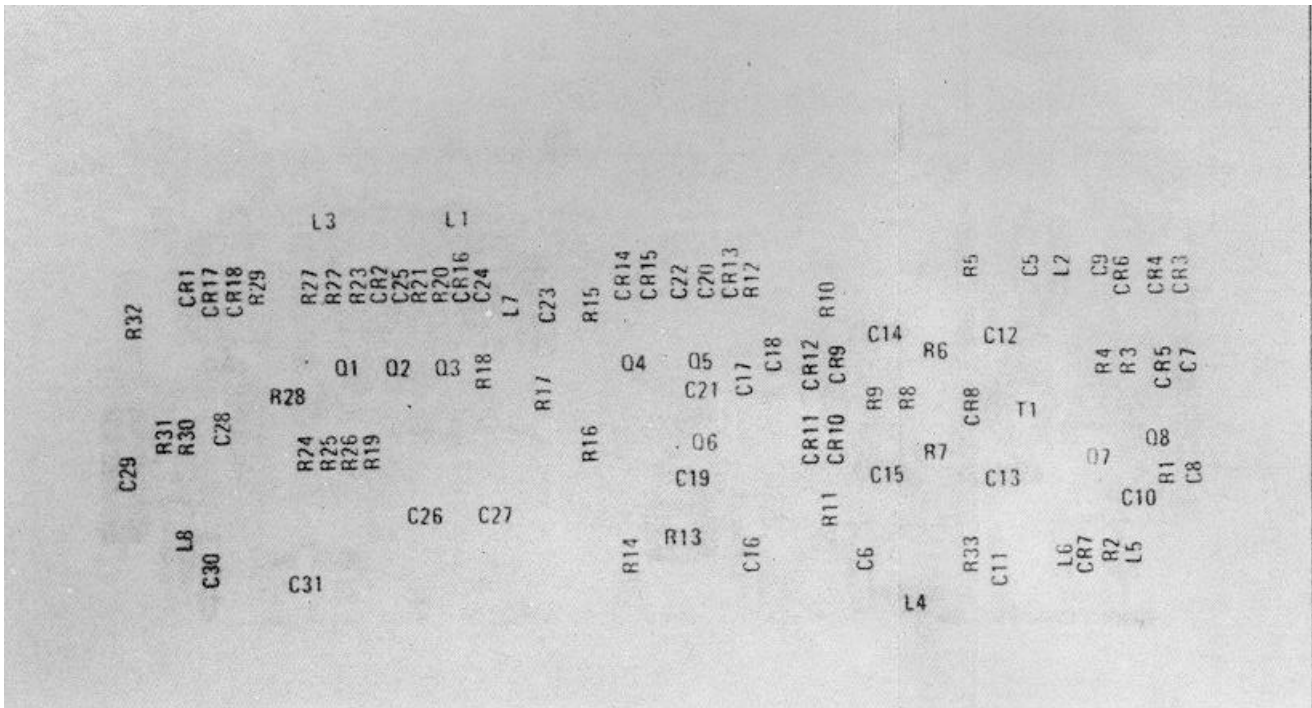

Figure 8-34. APC Assembly A6 (08553-6010) Component Locations

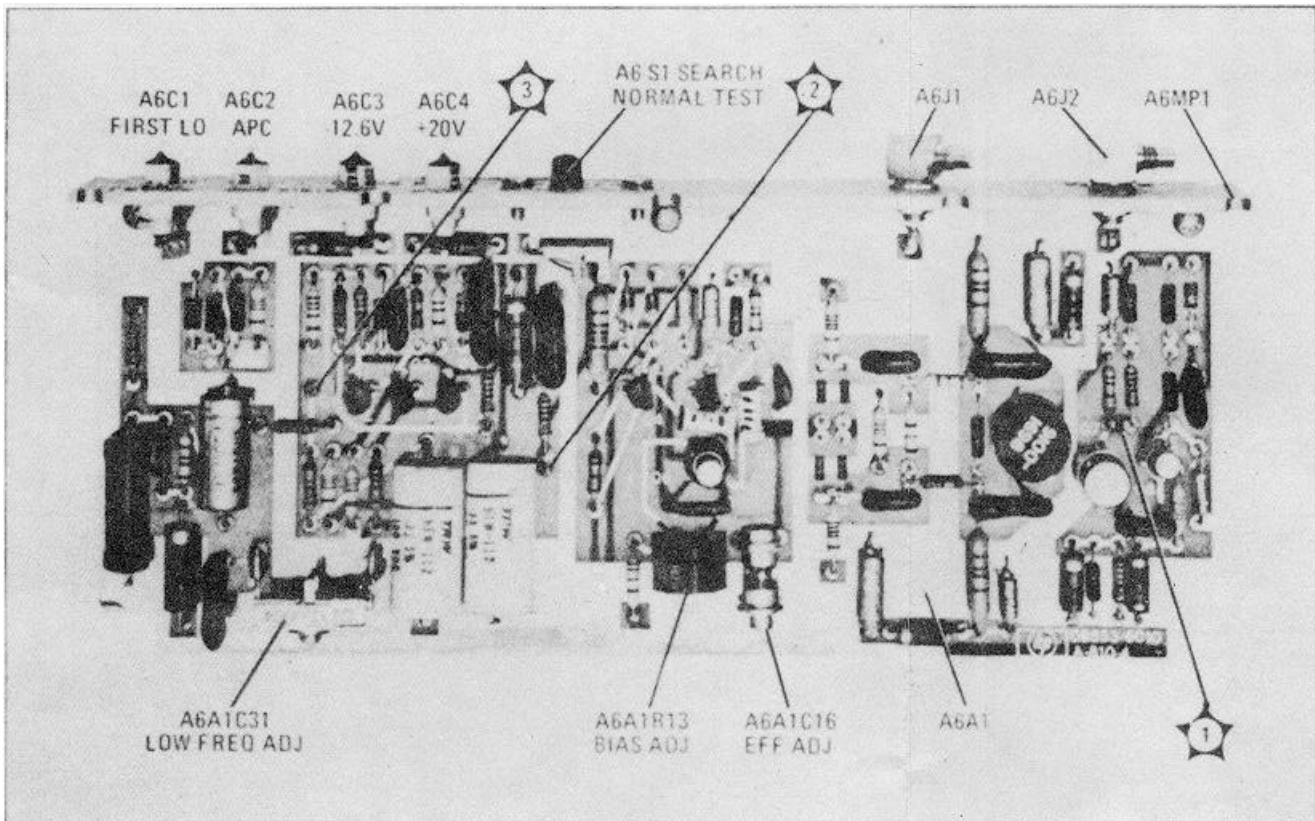

Figure 8-35. APC Assembly A6 (08553-6010) Adjustment and Test Connector Locations

SERVICE SHEET 7

It is assumed that proper operating voltages are present and that correct results could not be obtained in performing the tests specified in Paragraph 5-27 of Section V.

TROUBLESHOOTING PROCEDURE

When trouble has been isolated to the Reference Assembly it should be removed from the unit and reinstalled on the extender board to provide easy access to components. Troubleshooting information follows the technical discussions of individual circuits.

EQUIPMENT REQUIRED

Service Kit HP 11592A
 Oscilloscope..... HP 180A/1801A/1821A

CONTROL SETTINGS

The circuit under test is not affected by analyzer control settings.

1 1 MHz REFERENCE OSCILLATOR

Reference oscillator Q2/Q3 is crystal controlled to provide a stable signal for use in phase locking the first local oscillator in narrow scan width sweeps. The output of the oscillator is a 1.5 volt peak-to-peak sine wave at 1 MHz.

TEST PROCEDURE

Connect the HP 180A/1801A/1821A to TP 1 (Q3-c) and observe the waveform.

CONTROL SETTINGS:



Oscilloscope:
 0.1 μ/sec/Div
 0.05 V/Div
 10:1 probes
 Waveform GOOD: proceed to **2**
 Waveform BAD: Check Q2/Q3, Y1, and associated components

2 TRIGGER CIRCUIT

The positive half cycle of the 1 MHz sine wave from the reference oscillator is clipped by CR3. Trigger circuit Q6/Q7 inverts the negative half of the waveform from the reference oscillator and sharpens the leading edge of the resulting positive-going signal. The trigger circuit output is 6 volts peak-to-peak at 1 MHz.

TEST PROCEDURE

Connect the HP 180A/1801A/1821A to TP 2 (Q5-b) and observe the waveform.

CONTROL SETTINGS:

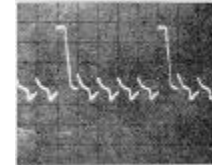

Oscilloscope:
 0.1 μ/sec/Div
 0.5 V/Div
 10:1 probes
 Waveform GOOD: proceed to **3**
 Waveform BAD: Check Q6/Q7 and associated components

3 DIVIDE-BY-FIVE CIRCUIT

The trigger output signal is differentiated by C12 and applied to the base of Q5. The signal is amplified and inverted by Q5 and applied to the base of Q4. Q4 amplifies and inverts the signal and applies it back to the base of Q5 in phase with the incoming signal to drive Q5 to saturation. This causes C13 to charge. At the end of the first pulse, the charge on C13 cuts Q5 off and keeps it cut off. C13 discharges through R14, and after 4 μs (4 pulses) the charge on C13 is low enough so that Q5 can again conduct. Therefore, Q5 conducts on every fifth pulse.

NOTE:

R11 is a factory selected component with a nominal value of 19.6K. Actual value is selected at time of final test as a period adjustment for the divide-by-five circuit.

TEST PROCEDURE:

Connect the HP 180A/1801A/1821A to TP 3 (junction of R15/R16/R14) and observe the waveform.

CONTROL SETTINGS:



Oscilloscope:
 1 μ/sec/Div
 0.1 V/Div
 10:1 probes
 Waveform GOOD: proceed to **4**
 Waveform BAD: Check Q4/Q5 and associated components

2 DIVIDE-BY-TWO CIRCUIT

The 200 kHz triggers from the divide-by-five circuit are coupled to bistable multivibrator Q8/Q9. Q9 changes state with every other incoming trigger

←SERVICE SHEET 6

Automatic Phase Control and Sampler/Amplifier Circuits

Section VIII

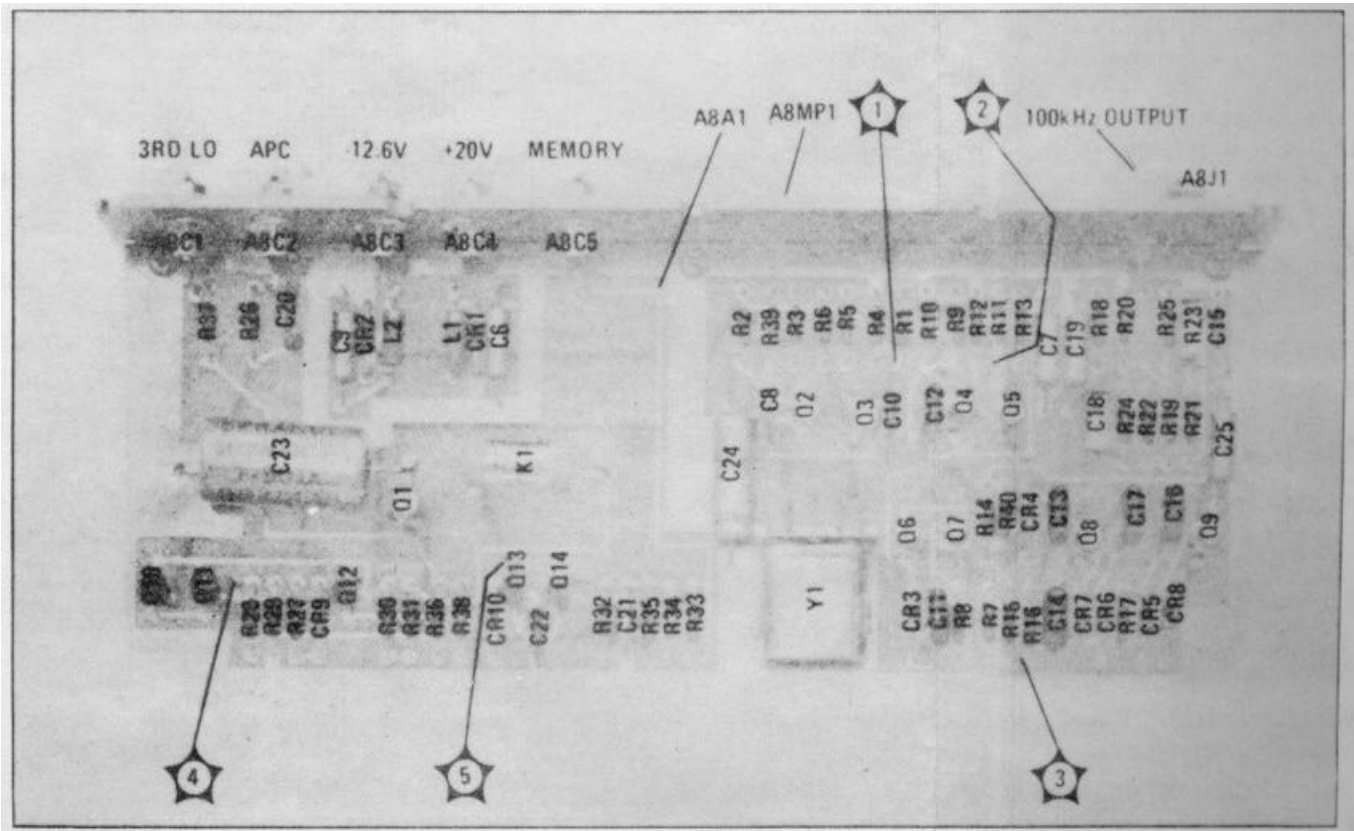

Figure 8-37. Reference Assembly A8 (08553-60131) Component Locations

SERVICE SHEET 8

1. Trouble isolated to summing/shaping of first local oscillator tuning voltage, preset scan amplifier, or marker generator circuits.
2. It is assumed that procedures in Paragraphs 5-23 and 5-32 of Section V could not be satisfactorily conducted, that preceding tests were satisfactory, and that proper dc operating voltages are present.

TROUBLESHOOTING PROCEDURES

1. If trouble has been localized to the first local oscillator summing or shaping circuits remove Voltage Control Assembly A5 and install it in the troubleshooting position using extender card HP 11592-60011.
2. Follow procedure steps shown under circuit theory for steps 1, 2, and 3.
3. If trouble has been localized to the preset scan amplifier or marker generator circuits, remove preset scan assembly A4 for maintenance.
4. Follow procedural steps shown under circuit theory for steps 4 and 5.

EQUIPMENT REQUIRED

Service KitHP 11592A
 Oscilloscope.....HP 180A/1801A/1821A
 Digital VoltmeterHP 3440A/3443A

CONTROL SETTINGS

As specified in individual tests.

1 FIRST LOCAL OSCILLATOR SUMMING AMPLIFIER

Operational amplifier Q5/Q6/Q7 sums tuning voltages to control the operating frequency of the first local oscillator. Attenuated ramp voltages from the scan width voltage divider and dc tuning voltage from the FREQUENCY control tune the analyzer in ZERO and PER DIVISION scan width modes. When the analyzer is stabilized in narrow scan width modes an APC voltage is also applied as an offset voltage to maintain frequency dial and display accuracy. The output of the operational amplifier is a symmetrical scan ramp centered on the dc level set by the FREQUENCY control. The ramp amplitude is determined by the scan width voltage divider. The FREQUENCY control determines center frequency on the display; SCAN WIDTH PER DIVISION determines the bandwidth of the signals to be displayed. In the 0 to 100 MHz scan width mode the summing amplifier is switched out of the first local oscillator circuit. Tuning range adjustment R13 provides dial calibration capability.

TEST PROCEDURES:

1-a. Connect Oscilloscope to Test Point A and observe waveform shown below.

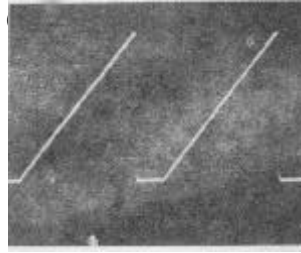

Oscilloscope:
 .2V/Div
 5 msec/Div
 10:1 probe
 Analyzer:
 PER DIVISION
 2 msec/Div
 10 MHz/Div

Waveform GOOD: proceed to step 1-b.
 Waveform BAD: Input signal not correct or Q7, C2 or R3 may be defective.

1-b. Connect Oscilloscope across R9 and observe waveform shown above.

CONTROL SETTINGS: Same as 1-a.

Waveform same as 1-a. GOOD: proceed to step 1-c.
 BAD: APC signal not correct or Q7 circuit may be defective. Also check Q6 and feedback circuits.

1-c. Connect Oscilloscope to Test Point C and observe waveform shown below.

CONTROL SETTINGS: Same as 1-a.

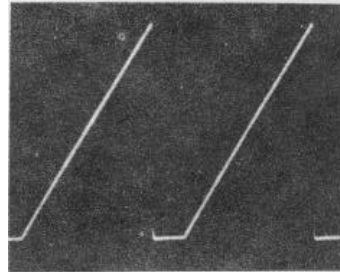

Waveform GOOD:
 Proceed to step 2
 Waveform BAD:
 Check Q5/Q6 and associated components

NOTE:

If the FREQUENCY control is suspect as a source of trouble, set SCAN WIDTH to 0-100 MHz and rotate the tuning control throughout its range while monitoring the dc level at Test Point C. 0 MHz = 0V, 110 MHz = 14.28V.

2 FIRST LOCAL OSCILLATOR SHAPING AMPLIFIER

The main frequency determining component in the first local oscillator, a varactor, is not a linear device; it requires an exponential voltage ramp to produce a linear change in frequency in respect to time. Operational amplifier Q2/Q3/Q4 provides an exponential ramp output when a linear ramp is applied to the input. This insures that the CRT display is linear in the frequency domain. Voltage

Section VIII

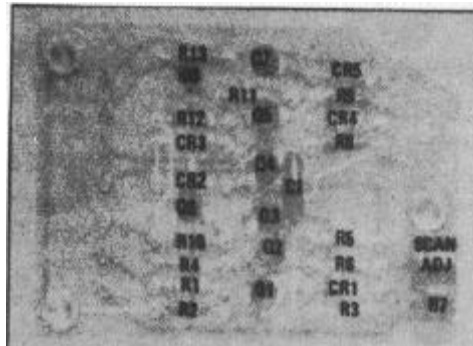

Figure 8-39. Preset Scan A4 (08553-6008) Connectors, Test Point Voltages and Components Locations.

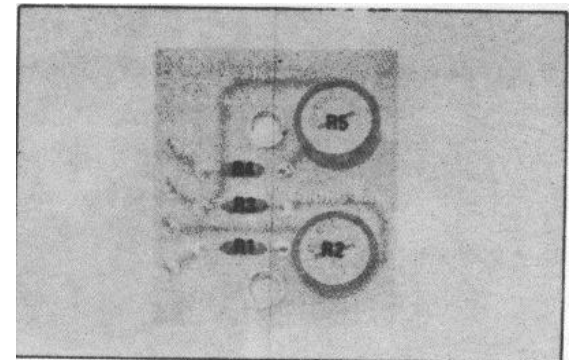

Figure 8-40. Frequency Range Assembly A13 (08553-60123) Adjustments and Components Locations.

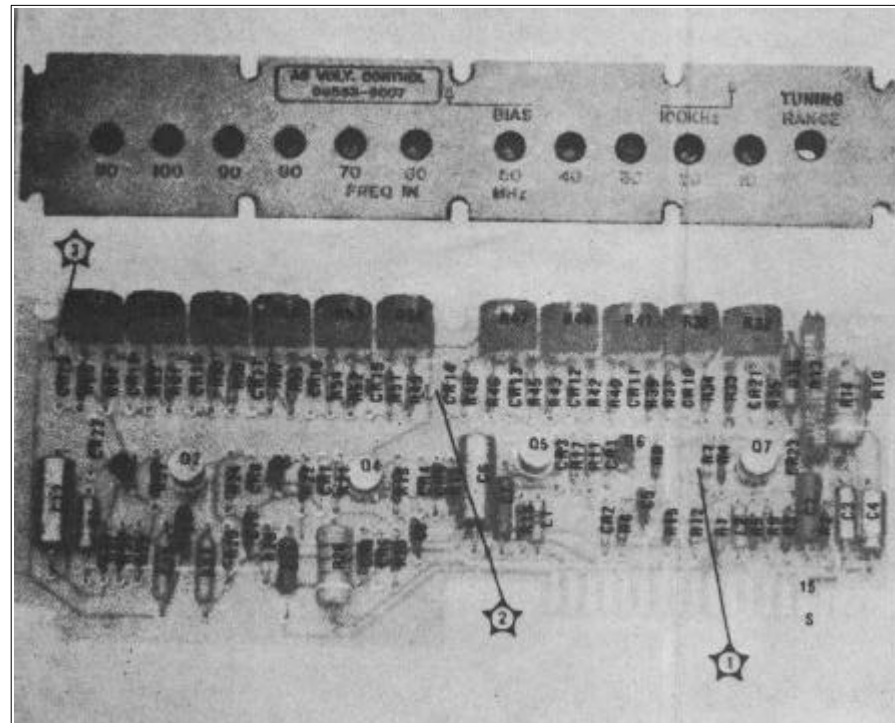

Figure 8-41. Voltage Control A5 (08553-6007) Adjustments, Test Points and Component Locations.

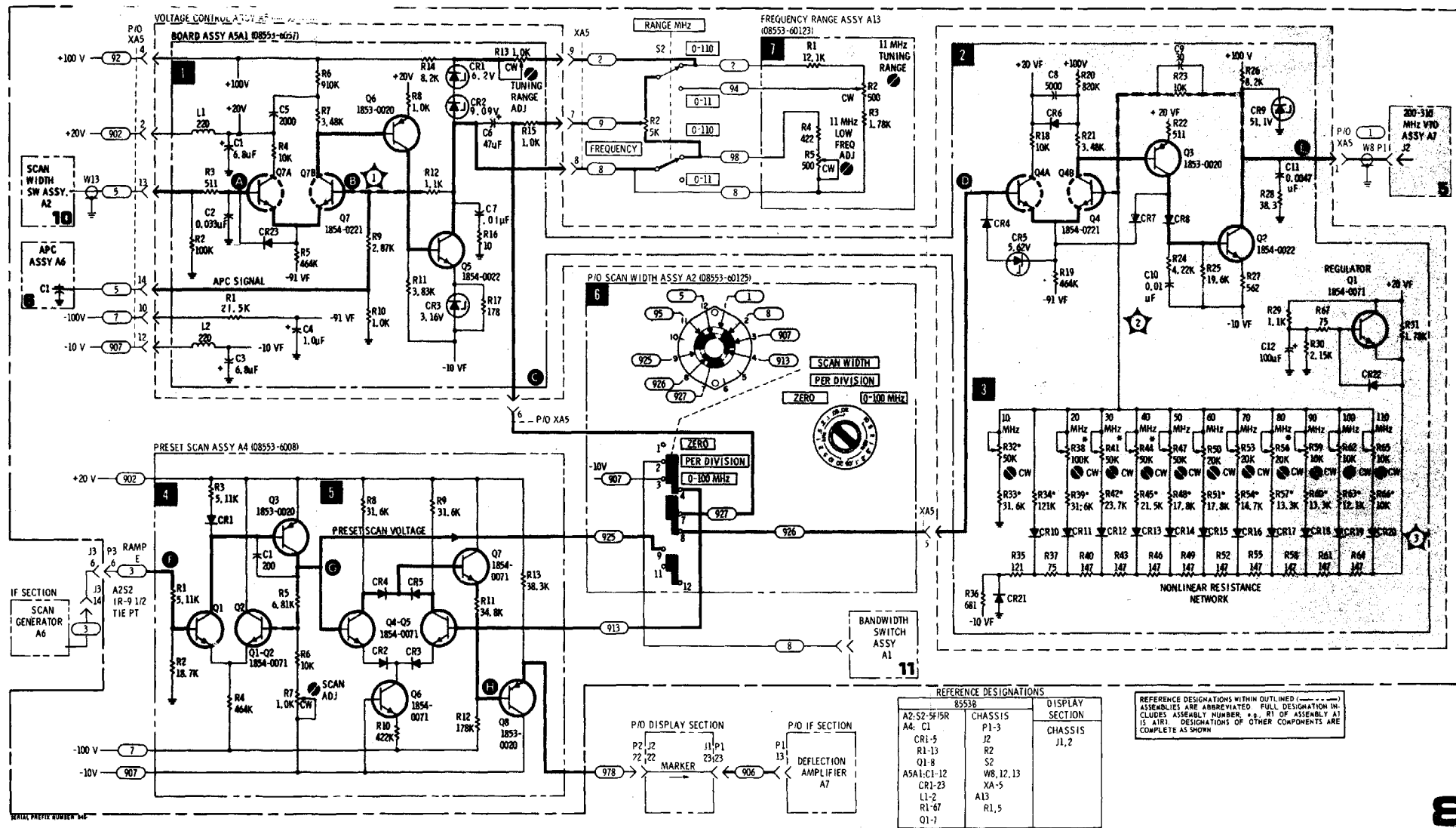

Figure 8-42. First LO Tuning Voltage, Marker Generator and Frequency Range Control Circuits.

SERVICE SHEET 8

First LO Tuning Voltage, Make Generator and
Frequency Range Control Circuits.

SERVICE SHEET 9

It is assumed that there is no 50 MHz input to the 50 MHz IF Amplifier and that the -10 Vdc operating voltage and 200 MHz IF input are both present.

TROUBLESHOOTING PROCEDURE

When the cause of malfunction has been isolated to the Second Converter Assembly it should be removed from the casting and installed in an inverted position using the fasteners provided in the Service Kit to provide access to components. Test procedures follow the discussions of individual circuits.

EQUIPMENT REQUIRED

- Service Kit HP 11592A
- Frequency Counter HP 5245L/5252A
- Vector Voltmeter HP 8405A
- 50-ohm Tee HP 11536A

CONTROL SETTINGS

- SCAN WIDTH ZERO
- INPUT ATTENUATION 0 dB
- FREQUENCY 30 MHz
- CAL OUTPUT connected to RF INPUT PUT

1 200 MHz IF BANDPASS FILTER

Signals from the 200 MHz IF Bandpass Filter are down converted to 50 MHz by the second converter. The input signal is mixed with a 150 MHz signal to obtain a 50 MHz IF signal containing the modulation components of the rf input. The amplitude of the 50 MHz IF signal is determined by the amplitude of the input rf signal. Conversion loss is approximately 7 dB.

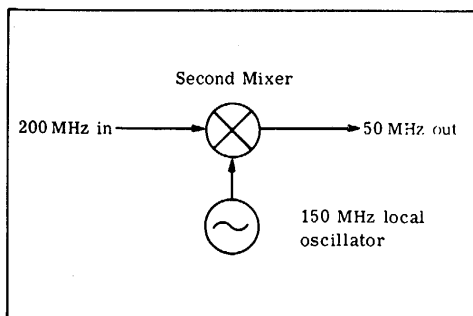

Figure 8-43. Simplified Diagram of Second Converter.

2 150 MHz LOCAL OSCILLATOR

The 150 MHz crystal controlled local oscillator provides two outputs. One output drives CR1 thru CR4 in the double balanced mixer; the other is applied to auxiliary output Jack J2.

TEST PROCEDURE

Connect the HP 8405A and the HP 5245L/5252A thru the 50 Ohm Tee to TP A (A10J2) and observe the indications. The instrument readings should show a 150 MHz signal at approximately 200 MHz rms. If the correct indications are not obtained, check Q1/Q2 and associated components.

If the correct indications are obtained, proceed step 3

4 SECOND MIXER

The second mixer accepts the 200 MHz IF signal and the 150 MHz local oscillator signal and mixes them to produce a difference signal of 50 MHz containing all of the modulation components appearing in the 200 MHz input signal. The 50 MHz output of the mixer is coupled from the secondary of T3 thru balun T4 to the processing circuits in the IF Section.

TEST PROCEDURE

Connect the HP 8405A and the HP 5245L/5252A thru the 50 Ohm Tee to TP B (A10J1) and observe the indications. The instrument readings should indicate a 50 MHz signal at approximately 70 mVrms.

If the correct output is obtained, Second Converter A10 is functioning properly.

If the correct output is not obtained, first tune t, 8553B FREQUENCY control to assure that the analyzer is tuned to the calibrator signal, then check the mixer circuit components, and repeat the test.

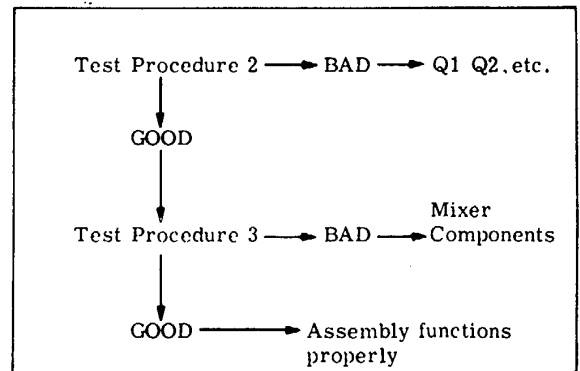

Simplified Test Procedure Tree

The following components are factory selected components. Values shown are nominal. Actual value is selected at time of final test inspection.

L4 is selected for compatibility with other circuit components.

R5 is selected to provide gain compensation.

SECTION VIII

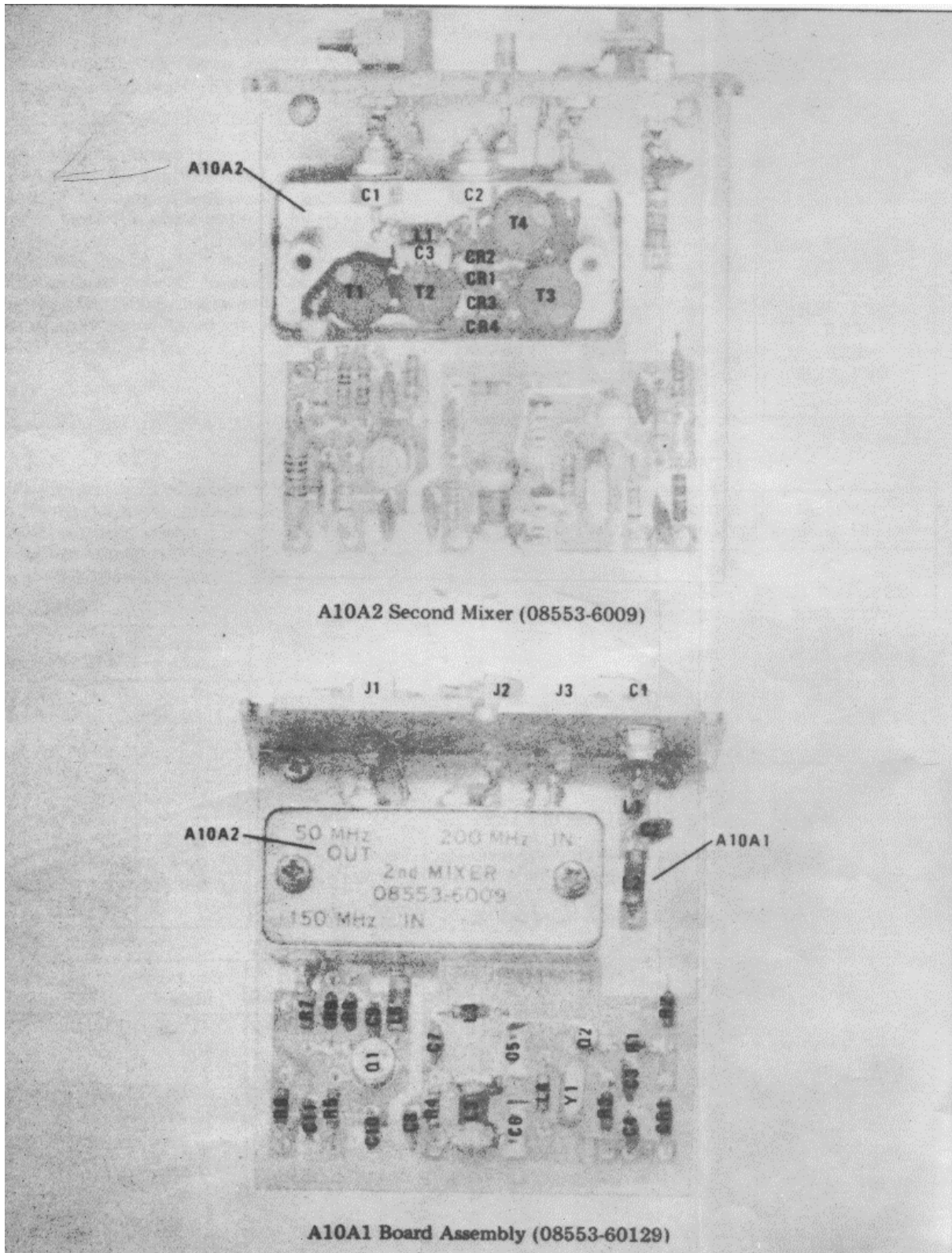

Figure 8-44. Second Converter A10 (08553-60132) Adjustments and Components Locations.

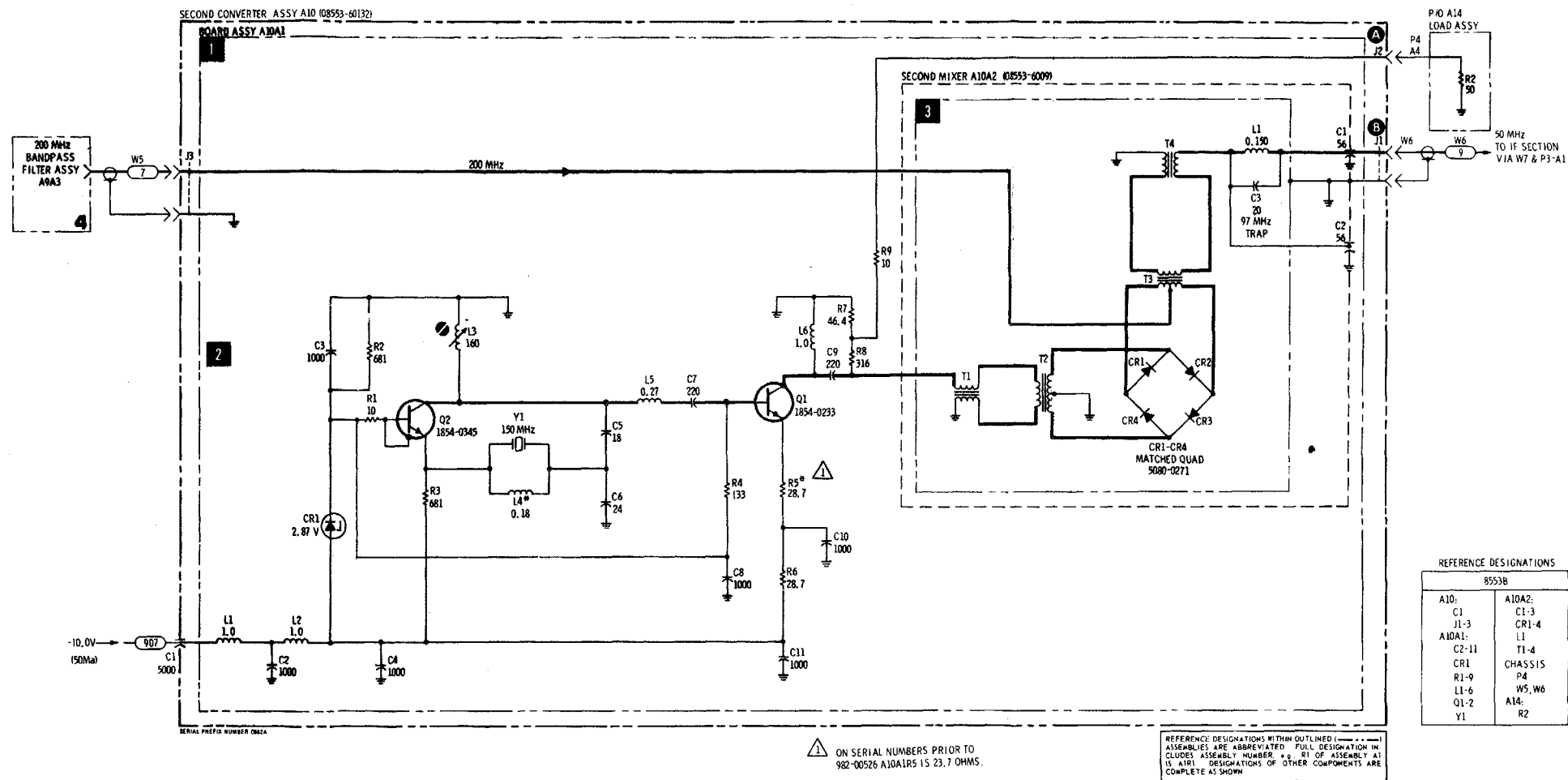

Figure 8-45. Second Converter.
8-41

SERVICE SHEET 9
Second Converter

SERVICE SHEET 10

It is assumed that the trouble has been isolated to that portion of the Scan Width Attenuator Assembly A2 shown in Service Sheet 10.

TROUBLESHOOTING PROCEDURE

Since there are no active components in the circuit to be repaired, the 8553B should be disconnected from the IF Section and the main frame, and an ohmmeter used for point-to-point measurements.

The following charts should isolate any trouble to a specific resistor, switch contact, or wire. Since each resistor is checked more than once, it is possible to verify resistor failure through different settings of S1 and S2 of A2.

EQUIPMENT REQUIRED

Volt-ohm-ammeterHP 410C

TEST PROCEDURE 1

Connect ohmmeter between ground and P3-31 or S1-1F-20. NOTE: It is difficult to take readings from P3-31 without shorting to adjacent pins. S1-1F-20 (white-orange-yellow lead) is readily accessible from the bottom of the unit.

SCAN WIDTH - PER DIVISION

PER DIVISION	Correct Reading	Incorrect Reading, Check
.02 kHz	18Ω	R20
.05	40	R21
0.1	56	R22
0.2	20	R19, R23
0.5	52	R25, R24
1.	102	R26
2.	200	R27
5.	500	R28, R29
10.	950	R30
20.	1850	R31
.05 to 10 MHz	0	

SCAN WIDTH - ZERO or 0-100 MHz

PER DIVISION	Correct Reading	Incorrect Reading, Check
.02 kHz	18Ω	R20
.05	40	R21
0.1	56	R22
0.2	20	R19, R23
0.5	52	R25, R24
1.	96	R26
2.	178	R27
5.	375	R28, R29
10.	500	R30
20.	0	
.05 to 10 MHz	0	

TEST PROCEDURE 2

Connect ohmmeter between ground and XA5-13.

SCAN WIDTH - ZERO or 0-100 MHz

PER DIVISION	Correct Reading	Incorrect Reading, Check
.02 -20 kHz	0Ω	
.05	56	R20, R21 R22
0.1	20	R23, R19,
0.2	40	R24
0.5	96	R25, R26
1.	180	R27
2.	320	R28
5.	500	R29, R30
10.	0	

SCAN WIDTH - PER DIVISION

PER DIVISION	Correct Reading	Incorrect Reading, Check
.02 -20 kHz	0Ω	
.05 MHz	55	R20, R21, R22
0.1	20	R23, R19
0.2	40	R24
0.5	100	R25, R26
1.	200	R27
2.	400	R28
5.	950	R29, R30
10.	1850	R32

TEST PROCEDURE 3

Connect ohmmeter between orange lead of A4 Pre-set Scan Assembly and XA5-13.

23.8K in all positions of switch.

SCAN WIDTH - PER DIVISION

PER DIVISION	Correct Reading	Incorrect Reading, Check
.02 to 20 kHz	1850Ω	Any except R20, R21, R22, R23
.05 MHz	1850	R19 thru R23
0.1	1825	
0.2	1800	
0.5	1760	
1.	1670	
2.	1470	
5.	960	
10.	0	

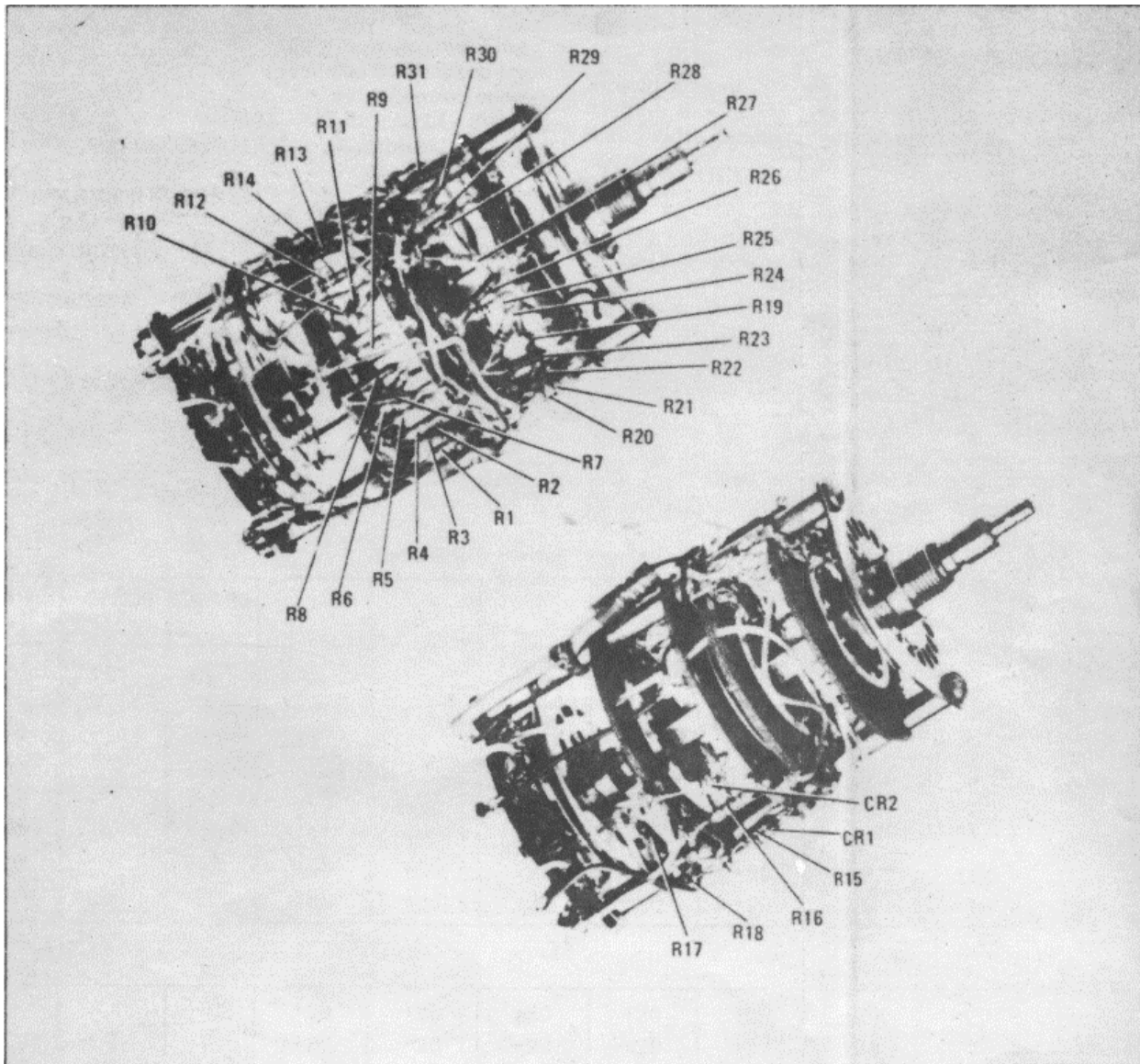

Figure 8-46. Scan Width Attenuator A2 (08553-60125) Component Locations.

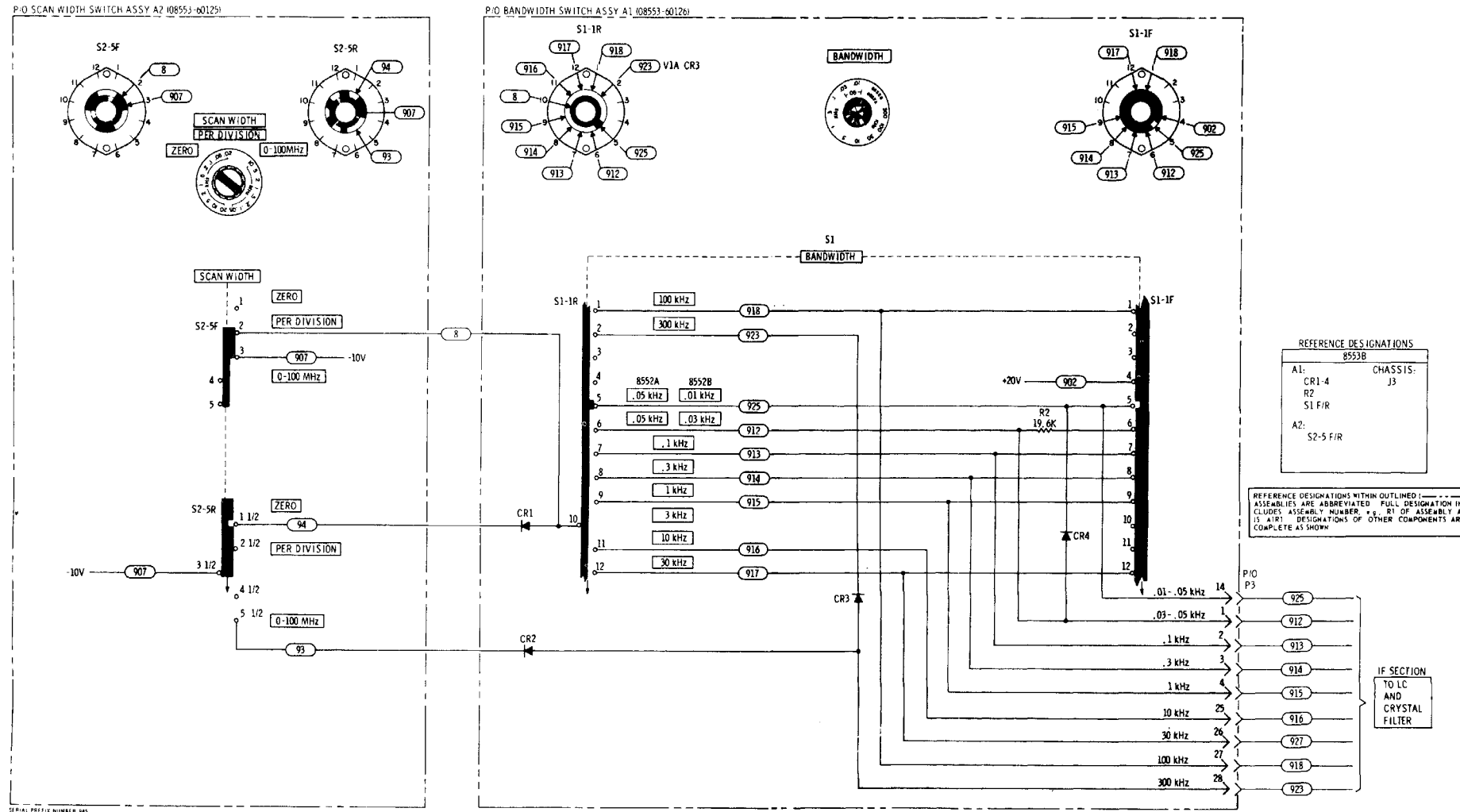

Figure 8-48. Bandwidth Control Circuits for IF Section.

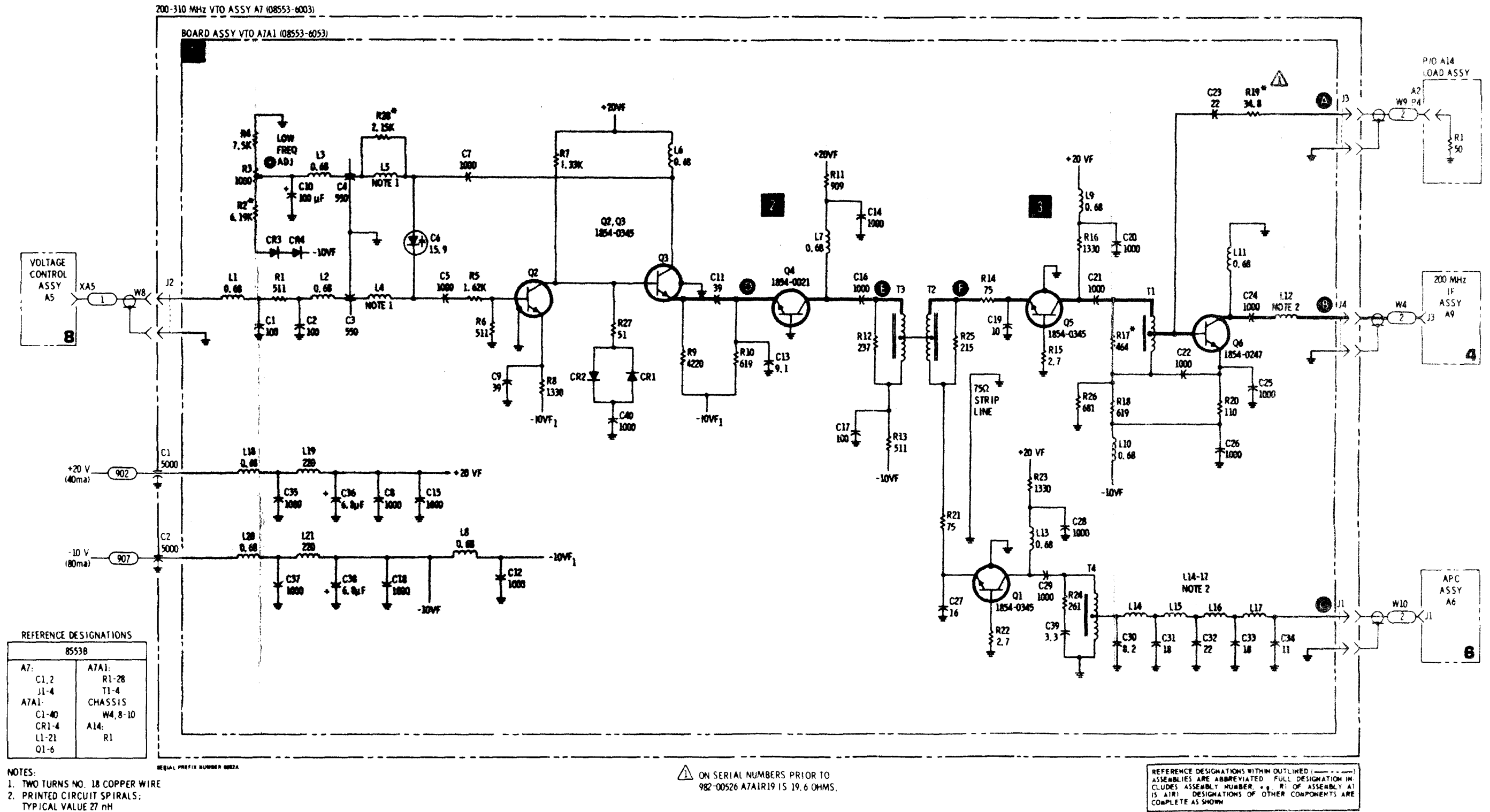

Figure 8-33. 200-301 MHz Voltage Tuned Oscillator (ERRATA)

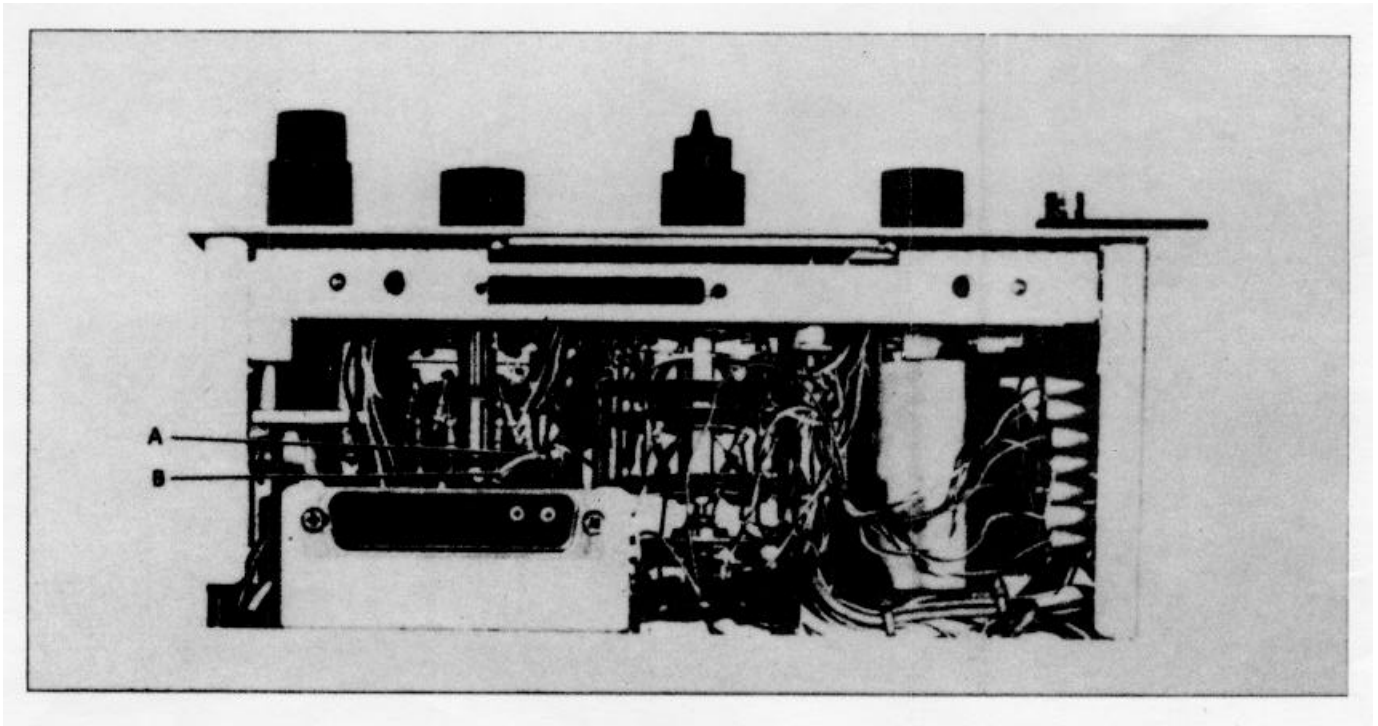

Figure 8-49. Bandwidth Switch A1 (08553-60126) Test Points

SERVICE TEST SHEET 11
Bandwidth Control Circuits for IF Section

SERVICE SHEET 12

It is assumed that the DISPLAY UNCAL lamp is operating erratically or not at all and that the adjustment procedure in the IF section Operating and Service Manual (see Analogic Test and Adjustment) will not correct the problem.

TROUBLESHOOTING PROCEDURE

When a malfunction has been isolated to the IF section analogic light driver or switching matrix, the Power Supply Assembly should be removed and re-installed using the extender board to provide access to components in the light driver circuit.

EQUIPMENT REQUIRED

- Service KitHP 11592A
- Digital Voltmeter HP 3440A/3443A

ANALOGIC CIRCUIT

The DISPLAY UNCAL light illuminates when the Scan Width Attenuator Assembly, the Scan Time Per Division Assembly, the Scan Width Per Division Assembly, the Bandwidth Switch Assembly, and the IF section Video Filter switch are set at any combination of positions which do not permit accurate calibration of the analyzer. The DISPLAY UNCAL lamp is caused to illuminate by a simulated signal and has no actual connection to signal processing circuits.

The SCAN TIME switch, the SCAN WIDTH switch, BANDWIDTH switch, and VIDEO FILTER switch all have wafers that are devoted exclusively to the analogic function. These switches control resistive networks that are connected from the -10 Vdc supply to the inputs of the analogic IF section threshold and light driver circuit. In the SCAN WIDTH PER DIVISION mode of operation these resistive networks are in parallel. At any time that the total resistance between the -10 Vdc supply and either input to the analogic circuit is low enough to bias Q20 or Q23 into conduction the light driver is enabled.

In the 0 to 100 MHz mode of operation, only the SCAN TIME switch and the IF section VIDEO FILTER switch control the analogic circuit.

In the ZERO scan mode, the analogic circuit is inoperative. (The VIDEO FILTER switch is still in the circuit but cannot, by itself, bias the analogic threshold and volt current into conduction.

TEST PROCEDURE

1-a. Connect the HP 3440A/3443A to the Bandwidth switch TP A. Set analyzer controls as follows:

- SCAN WIDTHPER DIVISION
- BANDWIDTH 10 kHz
- VIDEO FILTER OFF
- SCAN WIDTH PER DIVISION 20 kHz
- SCAN TIME PER DIVISION 1 msec

Meter should read about +580 mVdc DISPLAY UNCAL lamp off.

Place VIDEO FILTER switch in 10 kHz position Meter should read about -600 mVdc DISPLAY UNCAL remains on. Return VIDEO FILTER switch to OFF. Meter reads about +580 mVdc DISPLAY UNCAL lamp off.

Place SCAN TIME PER DIVISION switch in .5 msec/Div position. Meter should read about -2.4 volts DISPLAY UNCAL on.

If meter readings are correct but DISPLAY UNCAL does not illuminate, check DS1 and IF section analogic threshold and light driver. If voltages are incorrect check switches, resistors, wiring and IF section analogic threshold and light driver.

1-b. Connect the HP 3440A/3443A to BANDWIDTH switch TP B and set the analyzer controls as initially set in test 1-a. Meter should read about +165 mVdc.

Place VIDEO FILTER switch in the 10 kHz position. Meter should read about +50 mVdc DISPLAY UNCAL on.

Place VIDEO FILTER switch in the 100 Hz position. Meter should read about --40 mVdc DISPLAY UNCAL on. Return VIDEO FILTER switch to OFF. Meter reads about +165 mVdc DISPLAY [UNCAL off.

Place SCAN TIME PER DIVISION switch to .5 msec/Div. Meter should read about -1.4 volts DISPLAY UNCAL on. Return SCAN TIME PER DIVISION switch to 1 msec/Div. DISPLAY UNCAL off meter reads about +165 mVdc.

Place BANDWIDTH switch to 3 kHz position. Meter reads approximately -58 mVdc DISPLAY UNCAL on. Return BANDWIDTH switch to 10 kHz position. DISPLAY UNCAL off meter reads about +165 mVdc.

If readings are correct but DISPLAY UNCAL does not illuminate, check IF section analogic threshold and light driver.

If readings are incorrect check switches, resistors, wiring, etc.

NOTE

A further aid to troubleshooting is Table 3-1 in Section III. Using the table in conjunction with the schematic should aid in localizing cause o malfunction to specific components.

SCAN WIDTH SWITCH ASSY A2 (08553-60125); BANDWIDTH SWITCH ASSY A1 (08553-60126)

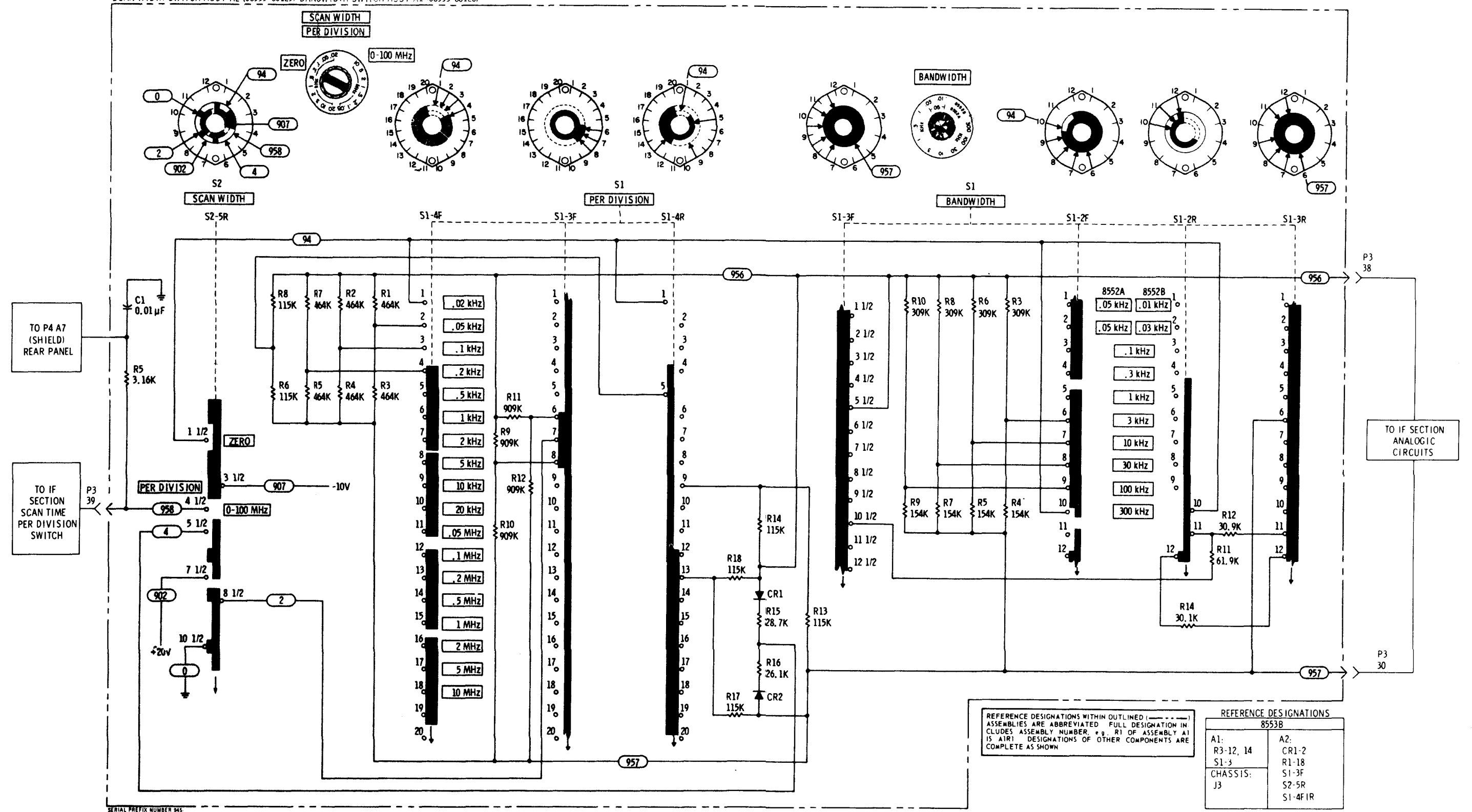

Figure 8-50. Analogic Switching Matrix

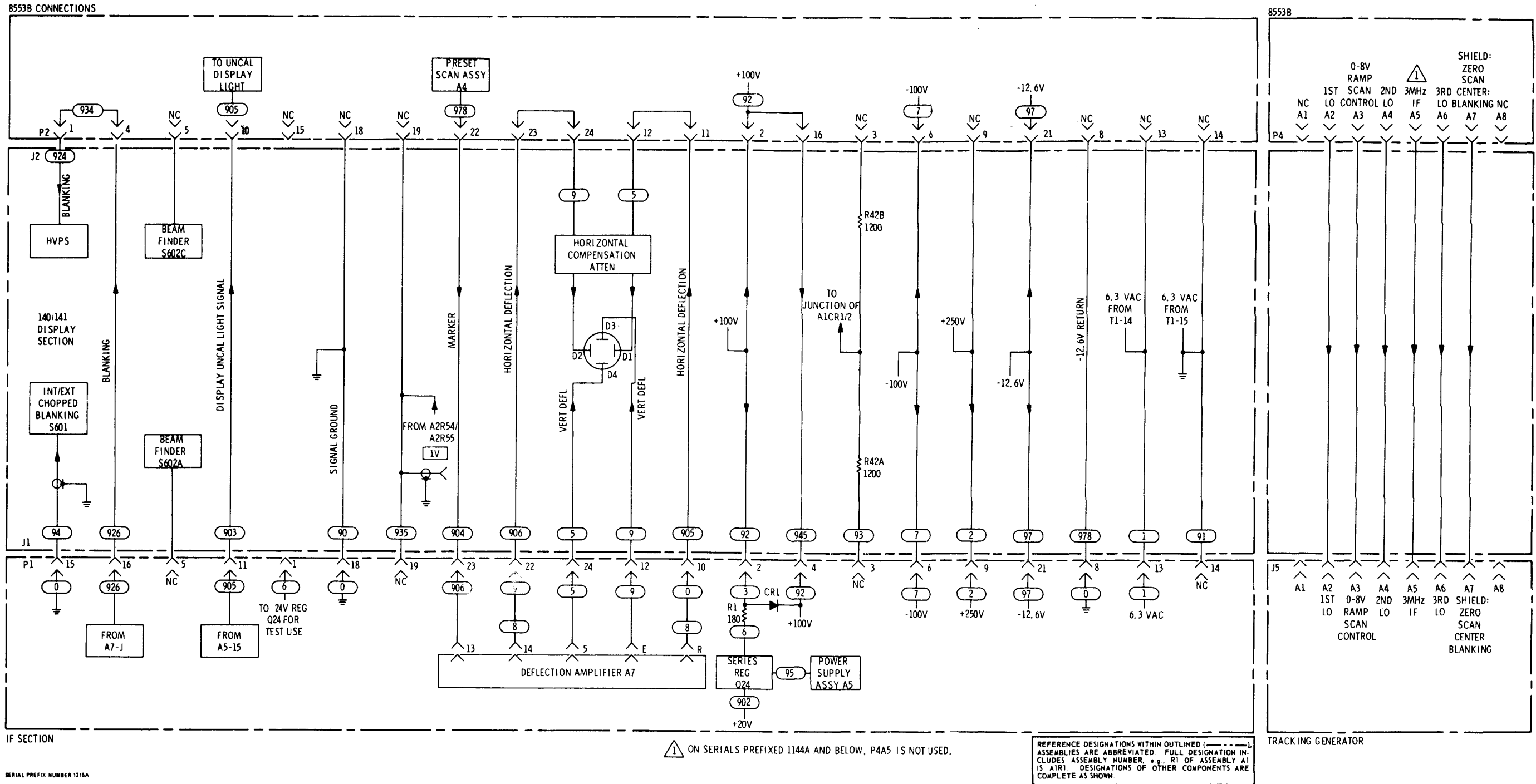

Figure 8-51. RF Section, Display Section Interconnections

APPENDIX A

REFERENCES

The following is a list of applicable references that are available to the operator and organizational repairman of Spectrum Analyzer RF Section, PL-1399/U.

DA Pam 310-4	Index of Technical Manuals, Technical Bulletins, Supply Manuals (types 7, 8, and 9), Supply Bulletins, and Lubrication Orders.
SB 11-573	Painting and preservation supplies available for field use for electronics command equipment.
TB 746-10	Field Instructions for Painting and Preserving Electronics Command Equipment.
TM 11-6625-2781-14 & P	Operator's, organizational, direct support and general support maintenance manual, including repair parts and special tools list for Spectrum Analyzer IP-1216(P)/GR (Hewlett-Packard Model 141T) (NSN 6625-00-424-4370).
TM 11-6625-2781-14-1	Operator's, organizational, direct support and general support maintenance manual for Plug-In Unit, Electric Test Equipment PL-1388/U (Hewlett-Packard Model 8552B) (NSN 6625-00-431-9339).
TM 11-6625-2781-24P-1	Department of the Army Technical Manual: organizational, direct support and general support maintenance repair parts and special tools list (including depot maintenance repair parts and special tools) for IF Plug-In PL-1388/U (Hewlett Packard Model 8552B) (NSN R66)-00-431-9339).

APPENDIX B
DIFFERENCE DATA SHEETS

The following manual changes must be made to the Technical Manual as a result of equipment production changes. The extent of the manual changes depends upon the serial prefix of the instrument.

B-1

MANUAL IDENTIFICATION	
Model Number:	8553B
Date Printed:	MAY 1980
Part Number:	08553-90043

This supplement contains important information for correcting manual errors and for adapting the manual to instruments containing improvements made after the printing of the manual.

To use this supplement:

Make all ERRATA corrections

Make all appropriate serial number related changes indicated in the tables below.

Serial Prefix or Number	Make Manual Changes ,
1215A05551 thru 1215A05900	1
1215A05901 thru 1630A08100	1, 2
1630A08101 thru 1630A prefix	1-3
1731A	1-4
1735A	1-5
1802A	1-6

Serial Prefix or Number	Make Manual Changes
1806A	1-7
1810A	1-8
1842A	1-9
1842A, Opt. H01/H02	1-8, 10
1913A	1-11
1937A	1-12

▶ NEW ITEM

ERRATA

Inside Front Cover:

Insert new information regarding SAFETY, CERTIFICATION, and WARRANTY AND ASSISTANCE inside front cover of Operating and Service Manual (new information on Page 2 of this Manual Changes Supplement).

Page 1-1, General Information:

Add Paragraph 1-A, shown in this Manual Changes Supplement, preceding Paragraph 1-1.

Page 1-1, Paragraph 1-12:

Add following sentences: "Option 005 is a half-hour video tape that describes the operation, calibration, and use of the HP 8553B Spectrum Analyzer. This 1/2-inch, reel-type tape is Corporate Training Tape 90030 C 607."

Page 1-3, Table 1-1, AMPLITUDE SPECIFICATIONS:

Change Dynamic Range, Average Noise Level to >-110 dBm.

Change Residual Responses to read: 200 kHz - 110 MHz <-110 dBm, 20 kHz - 200 kHz <-95 dBm.

Page 1-4, Table 1-1, FREQUENCY SPECIFICATIONS:

Change Scan Width Preset to read: 0 - 100 MHz (300 kHz bandwidth only).

Change Resolution Bandwidth Selectivity to read: 60 dB/3 dB IF bandwidth ratios: <11:1 for IF bandwidths 30 Hz to 3 kHz, <20:1 for IF bandwidths from 10 kHz to 300 kHz, 60 dB points separated by <100 Hz for 10 Hz bandwidth.

Page 1-5, Table 1-2, FREQUENCY CHARACTERISTICS:

Change Long Term Drift, Stabilized, to 500 Hz/10 min.

Change Temperature Drift, Stabilized, to 2 kHz/° C.

NOTE

Manual change supplements are revised as often as necessary to keep manuals as current and accurate as possible. Hewlett-Packard recommends that you periodically request the latest edition of this supplement. Free copies are available from all HP offices. When requesting copies quote the manual identification information from your supplement, or the model number and print date from the title page of the manual.

SAFETY

This instrument has been designed and tested according to International Safety Requirements. To ensure safe operation and to keep the instrument safe, the information, cautions, and warnings in this manual must be heeded. Refer to Section I for general safety considerations applicable to this instrument.

CERTIFICATION

Hewlett-Packard Company certifies that this instrument met its published specifications at the time of shipment from the factory. Hewlett-Packard Company further certifies that its calibration measurements are traceable to the United States National Bureau of Standards, to the extent allowed by the Bureau's calibration facility, and to the calibration facilities of other International Standards Organization members.

WARRANTY AND ASSISTANCE

This Hewlett-Packard product is warranted against defects in materials and workmanship for a period of one year from the date of shipment. Hewlett-Packard will, at its option, repair or replace products which prove to be defective during the warranty period provided they are returned to Hewlett-Packard. Repairs necessitated by misuse of the product are not covered by this warranty. NO OTHER WARRANTIES ARE EXPRESSED OR IMPLIED, INCLUDING BUT NOT LIMITED TO THE IMPLIED WARRANTIES OF MERCHANTABILITY AND FITNESS FOR A PARTICULAR PURPOSE. HEWLETT-PACKARD IS NOT LIABLE FOR CONSEQUENTIAL DAMAGES.

Service contracts or customer assistance agreements are available for Hewlett-Packard products that require maintenance and repair on-site.

For any assistance contact your nearest Hewlett-Packard Sales and Service Office. Addresses are provided at the back of this manual.

1-A. SAFETY CONSIDERATIONS

Safety Symbols



Instruction manual symbol: the apparatus will be marked with this symbol when it is necessary for the user to refer to the instruction manual in order to protect the apparatus against damage.



Indicates dangerous voltages.



Earth terminal (sometimes used in manual to indicate circuit connected to grounded chassis).

WARNING

The **WARNING** sign denotes a hazard. It calls attention to a procedure, practice, or the like, which, if not correctly performed or adhered to, could result in injury or loss of life. Do not proceed beyond a **WARNING** sign until the indicated conditions are fully understood and met.

CAUTION

The **CAUTION** sign denotes a hazard. It calls attention to an operating procedure, practice, or the like, which, if not correctly performed or adhered to, could result in damage to or destruction of part or all of the equipment. Do not proceed beyond a **CAUTION** sign until the indicated conditions are fully understood and met.

Operation

CAUTION

BEFORE APPLYING POWER make sure the instrument's ac input is set for the available ac line voltage, that the correct fuse is installed, and that all normal safety precautions have been taken.

Service

The information, cautions, and warnings in this manual must be followed to ensure safe operation and to keep the instrument safe. **SERVICE AND ADJUSTMENTS SHOULD BE PERFORMED ONLY BY QUALIFIED SERVICE PERSONNEL.**

Adjustment or repair of the opened instrument with the ac power connected should be avoided as much as possible and, when unavoidable, should be performed only by a skilled person who knows the hazard involved.

Capacitors inside the instrument may still be charged even though the instrument has been disconnected from its source of supply.

Make sure only fuses of the required current rating and type (normal blow, time delay, etc.) are used for replacement. Fuse requirements are indicated on the instrument's rear panel. Do not use repaired fuses or short-circuit fuse holders.

Whenever it is likely that the protection has been impaired, make the instrument inoperative and secure it against any unintended operation.

WARNING

If this instrument is to be energized through an auto-transformer (for voltage reduction), make sure the common terminal is connected to the earthed pole of the power source.

BEFORE SWITCHING ON THE INSTRUMENT, the protective earth terminal of the instrument must be connected to the protective conductor of the (mains) power cord.

The mains plug shall only be inserted in a socket outlet provided with protective earth contact. The protection action must not be negated by using an extension cord (power cable) without a protective grounding conductor. Grounding one conductor of ; two-conductor outlet is not sufficient protection.

Any interruption of the protective (grounding) conductor, inside or outside the instrument, or disconnection of the protective earth terminal is likely to make this instrument dangerous. Intentional interruption of the earth ground is prohibited. Whenever it is likely that the protection has been impaired, the instrument must be secured against any unintended operation.

Servicing this instrument often requires that you work with the instrument's protective covers removed and with ac power connected. Be very careful; the energy at many points in the instrument may, if contacted, cause personal injury.

ERRATA (Cont'd)

Page 1-6, Table 1-2, AMPLITUDE CHARACTERISTICS, Video Filter:
 Change " ... and 10 Hz bandwidths" to " and 10 Hz (8552B IF only) bandwidths."
 Page 1-6, Table 1-2, RF INPUT CHARACTERISTICS, Impedance:
 Change " ... such as Anzac TDN-5350" to " such as HP 11694A."

Page 4-1:
 Delete paragraphs 4-12 through 4-21 and replace with new paragraphs 4-12 through 4-21 provided in this Manual Changes supplement.

Page 4-11, Step 1:
 Change ANALYZER RANGE MHz to read: 0 - 110.

Page 4-17, Figure 4-12:
 Change as shown in Figure 4-12 (Errata).

Page 4-18, Paragraph 4-29:
 Replace entire Residual Responses test with paragraph 4-29 shown in this supplement.

Page 4-24, Table 4-3:
 Change entry for Residual Responses to the following:

Para. No.	Test Description	Measurement Units	Min	Actual	Max
4-29	Residual Responses				
	60-110 MHz; Residual Responses down <-110 dBm	dBm	-110	_____	
	0-60 MHz; Residual Responses down <-110 dBm	dBm	-110	_____	
	1-10 MHz; Residual Responses down <-110 dBm	dBm	-110	_____	
	200 kHz-1 MHz; Residual Responses down <-110 dBm	dBm	-110	_____	
	20-200 kHz; Residual Responses down <-95 dBm	dBm	- 95	_____	

Page 5-1, Paragraph 5-3:
 Add the following:

WARNING

Adjustments described herein are performed with power supplied to the instrument while protective covers are removed. Energy available at many points may, if contacted, result in personal injury.

Page 5-1, Paragraph 5-12:
 Add the following:

WARNING

Before proceeding to the next step, make sure the Display Section power is OFF.

ERRATA (Cont'd)

Page 5-14, Paragraph 5-26:

Change the HP Part Number of the Interconnection Cable Assembly to HP 08443-60009.

Page 6-1, Table 6-1:

Change as shown in Table 6-1 (Errata).

Page 6-2, Table 6-3:

Delete second A1 entry.

Add after A1CR4: A1MP1, HP Part Number 08553-00134, Qty 1, Description; DIAL:

KNOB ASSY (BANDWIDTH), Mfr Code 28480, Mfr Part Number 08553-00134.

Delete second and third A2 entries.

Add after A2MP2: A2MP3 and A2MP4 as follows:

A2MP3, HP Part Number 08553-00135, Qty 1, Description; DIAL: KNOB ASSY (SCAN WIDTH), Mfr Code 28480, Mfr Part Number 08553-00135.

A2MP4, HP Part Number 0370-0102, Qty 1, Description; KNOB: RED BAR, Mfr Code 28480, Mfr Part Number 0370-0102.

Delete second A3 entry.

Add after A311P2: A3MP3, HP Part Number 08553-00133, Qty 1, Description; DIAL: KNOB ASSY (INPUT ATTENUATION), Mfr Code 28480, Mfr Part Number 08553-00133.

A3MP4, HP Part Number 08553-4003, Description; EXTENSION: SHAFT, Mfr Code 28480, Mfr Part Number 085534003.

A3MP5, HP Part Number 3130-0194, Description; SHAFT AND INDEX (DETENT) ASSY, Mfr Code 28480, Mfr Part Number 3130-0194.

A3MP6, HP Part Number 3103-0197, Description; PLATE: SPACER, Mfr Code 28480, Mfr Code 28480, Mfr Part Number 3130-0197.

A3MP7, HP Part Number 3130-0198, Description; PLATE: SPACER, Mfr Code 28480, Mfr Part Number 3130-0198.

A3MP8, HP Part Number 3130-0198, Description; PLATE: SPACER, Mfr Code 28480, Mfr Code 28480, Mfr Part Number 3130-0198.

A3MP9, HP Part Number 3130-0197, Description; PLATE: SPACER, Mfr Code 28480, Mfr Part Number 3130-0197.

A3MP10, HP Part Number 3130-0198, Description; PLATE: SPACER, Mfr Code 28480, Mfr Part Number 3130-0198.

A3MP11, HP Part Number 3130-0198, Description; PLATE: SPACER, Mfr Code 28480, Mfr Part Number 3130-0198.

A3MP12, HP Part Number 3130-0197, Description; PLATE: SPACER, Mfr Code 28480, Mfr Part Number 3130-0197.

Page 6-3, Table 6-3:

Delete first A3S1 entry.

Change second A3S1 entry to A3S1-1.

Change third A3S1 entry to A3S1-2.

Change fourth A3S1 entry to A3S1-3.

Change fifth A3S1 entry to A3S1-4.

Change sixth A3S1 entry to A3S1-5.

Add after A4CR5: A4MP1 and A4MP2 as follows:

A4MP1, HP Part Number 0360-0124, Qty 8, Description; TERMINAL: SOLDER LUG, Mfr Code 28480, Mfr Part Number 0360-0124.

A4MP2, HP Part Number 0380-0863, Qty 1, Description; STANDOFF: 1/8" LG Mfr Code 06540, Mfr Part Number 9531-125-B0440-0.

Delete second, third, and fourth A4 entries.

Delete word MISCELLANEOUS in Description column opposite second A4 entry.

▶ Change A4R6 to HP Part Number 0757-0288, Check Digit 1, RESISTOR 9.09K 1% .125W F TC=0+-100. (Recommended Replacement.)

▶ Change A4R7 to HP Part Number 2100-1759, Check Digit 4, RESISTOR-TRMR 2K 5% WW SIDE-ADJ 1-TRN.

(Recommended Replacement.)

ERRATA (Cont'd)

Page 6-4, Table 6-3:

Add after A5A1L2: A5A1MP1, HP Part Number 0360-0124, Description; TERMINAL: SOLDER LUG, Mfr Code 28480, Mfr Part Number 0360-0124.

Change A5A1R6 to HP Part Number 0698-8961, Check Digit 7, RESISTOR 909K 1% .125W F TC=O+-100.

Change A5A1R32 Description, second line, to read: "(FACTORY SELECTED PART, TYPICAL VALUE SHOWN).
Delete second A5A1R32 entry.

Change A5A1R33 Description, second line, to read: "(FACTORY SELECTED PART, TYPICAL VALUE SHOWN)."
Delete second A5A1R33 entry.

Change A5A1R34 Description, second line, to read: "(FACTORY SELECTED PART, TYPICAL VALUE SHOWN)."
Delete second A5A1R34 entry.

Change A5A1R38 Description, second line, to read: "(FACTORY SELECTED PART, TYPICAL VALUE SHOWN)."
Delete second A5A1R38 entry.

Change A5A1R39 Description, second line, to read: "(FACTORY SELECTED PART, TYPICAL VALUE SHOWN)."
Delete second A5A1R39 entry.

Change A5A1R41 Description, second line, to read: "(FACTORY SELECTED PART, TYPICAL VALUE SHOWN)."
Delete second A5A1R41 entry.

Change A5A1R42 Description, second line, to read: "(FACTORY SELECTED PART, TYPICAL VALUE SHOWN)."
Delete second A5A1R42 entry.

Change A5A1R44 Description, second line, to read: "(FACTORY SELECTED PART, TYPICAL VALUE SHOWN)."
Delete second A5A1R44 entry.

Change A5A1R45 Description, second line, to read: "(FACTORY SELECTED PART, TYPICAL VALUE SHOWN)."
Delete second A5A1R45 entry.

Change A5A1R47 Description; second line, to read: "(FACTORY SELECTED PART, TYPICAL VALUE SHOWN)."
Delete second A5A1R47 entry.

Change A5A1R48 Description, second line, to read: "(FACTORY SELECTED PART, TYPICAL VALUE SHOWN)."
Delete second A5A1R48 entry.

Change A5A1R51 Description, second line, to read: "(FACTORY SELECTED PART, TYPICAL VALUE SHOWN)."
Delete second A5A1R51 entry.

Change A5A1R41* to HP Part No. 2100-3354, Check Digit 9, R-VT 50K 10% IT (Recommended Replacement).

Change A5A1 R44* to HP Part No. 2100-3354, Check Digit 9, R-VT 50K 10% IT (Recommended Replacement).

Change A5A1 R47 to HP Part No. 2100-3354, Check Digit 9, R-VT 50K 10% IT (Recommended Replacement).

Change A5A1R50 to HP Part No. 2100-3353, Check Digit 8, R-.T 20K 10% IT (Recommended Replacement).

Page 6-5, Table 6-3:

Change A5A1R54 Description, second line, to read: "(FACTORY SELECTED PART, TYPICAL VALUE SHOWN)."
Delete second A5A1R54 entry.

Change A5A1R56 Description, second line, to read: "(FACTORY SELECTED PART, TYPICAL VALUE SHOWN)."
Delete second A5A1R56 entry.

Change A5A1R57 Description, second line, to read: "(FACTORY SELECTED PART, TYPICAL VALUE SHOWN)."
Delete second A5A1R57 entry.

Change A5A1R60 Description, second line, to read: "(FACTORY SELECTED PART, TYPICAL VALUE SHOWN)."
Delete second A5A1R60 entry.

Change A5A1R63 Description, second line, to read: "(FACTORY SELECTED PART, TYPICAL VALUE SHOWN)."
Delete second A5A1R63 entry.

Change A5A1R66 Description, second line, to read: "(FACTORY SELECTED PART, TYPICAL VALUE SHOWN)."
Delete second A5A1R66 entry.

Delete both A5A1 entries.

Delete word MISCELLANEOUS in Description column opposite first A5A1 entry.

ERRATA (Cont'd)

Table 6-1. Part Numbers for Assy Exchange Orders

8553B	Assembly	Part Number	Exchange Assy Part Number
A8	Reference Oscil.	08553-60131	60134
A10	Second Converter	08553-60132	60135

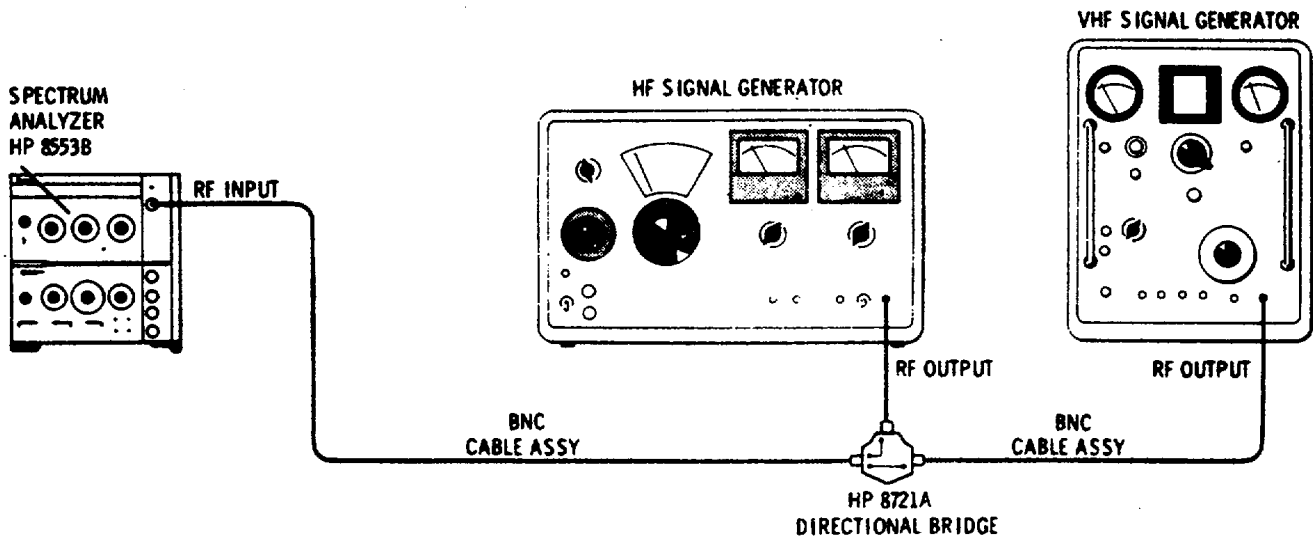

Figure 4-12. Intermodulation Distortion Test (ERRATA)

Page 6-5, Table 6-3:

- Change A5A1R53 to HP Part No. 2100-3353, Check Digit 8, R-VT 20K 10%S 1T (Recommended Replacement).
- Change A5A1R56* to HP Part No. 2100-3353, Check Digit 8, R-VT 20K 10% IT (Recommended Replacement).
- Change A5A1R59 to HP Part No. 2100-3274, Check Digit 2, R-VT 10K 10%c IT (Recommended Replacement).
- Change A5A1R62 to HP Part No. 2100-3274, Check Digit 2, R-VT 10K 10% IT (Recommended Replacement).
- Change ASA1R65 to HP Part No. 2100-3274, Check Digit 2. R-VT 10K 10% IT (Recommended Replacement).
- Change A6A1C7 to HP Part Number 0160-2204, C: FXD MICA 100PF 5% 300VDCW, 72136, RDM15F01J3C.
- Change A6A1C18 to HP Part Number 0150-0073, C: FXD CER 100PF 10% 500VDCW, 56289, C028B102E101KS27-CDH.
- Change A6A1CR9 and A6A1CR10 to HP Part Number 1901-0518, DIODE: SILICON, 28410, 1901-0518.

Page 6-6, Table 6-3:

- Change A6A1R6 Description, second line, to read: "(FACTORY SELECTED PART, TYPICAL VALUE SHOWN)."
- Delete second A6A1R6 entry.
- Change A6A1R8 Description, second line, to read: "(FACTORY SELECTED PART, TYPICAL VALUE SHOWN)."
- Delete second A6A1 R8 entry.

ERRATA (Cont'd)

Page 6-7, Table 6-3:

Change A7A1C39 to A7A1C39*, HP Part No. 0160-2262, Check Digit 0, CAPACITOR-FXD 16 PF +-5% 500 VDC CER 0+-30 (FACTORY SELECT).

Change A7A1Q6 second entry to A7A1Q6MP1.

Change A7A1 R2 Description, second line, to read: "(FACTORY SELECTED PART, TYPICAL VALUE SHOWN)."

Delete second A7A1R2 entry.

Change A7A1R2* to HP Part Number 0757-0313 (Check Digit = 7), RESISTOR 1.33K OHM 1% .125W F TC= 0 +-100.

Page 6-8, Table 6-3:

Change A7A1R1 7 Description, second line, to read: "(FACTORY SELECTED PART, TYPICAL VALUE SHOWN)."

Delete A7A1R17 second entry.

Change A7A1 R19 Description, second line, to read: "(FACTORY SELECTED PART, TYPICAL VALUE SHOWN)."

Delete second A7A1R19 entry.

Change A7A1R22 Description. second line, to read: "(FACTORY SELECTED PART, TYPICAL VALUE SHOWN)."

Delete second A7A1R22 entry.

Change A7A1 R24 Description, second line, to read: "(FACTORY SELECTED PART, TYPICAL VALUE SHOWN)."

Delete second A7A1R24 entry.

Change A7A1 R28 Description, second line, to read: "(FACTORY SELECTED PART, TYPICAL VALUE SHOWN)."

Delete second A7A1R28 entry.

Change A7A1R29* to HP Part Number 0698-3446 (Check Digit = 3), RESISTOR 383 OHM 1% .125W F TC=0 +-100.

Page 6-9, Table 6-3:

Change A8A1R35 to HP Part Number 0698-8961, Check Digit 7, RESISTOR 909K 1% .125W F TC=0+-100.

Change A9A1C8 HP Part Number to 0121-0036.

Add A9A1C8 Description: C: VAR TRMR CER 5.5-1.8 PF 350V (FACTORY SELECTED PART, TYPICAL VALUE SHOWN), Mfr Code 73899, Mfr Part Number DV1 PR 8A.

Page 6-10, Table 6-3:

Delete A9A1C8 Reference Designation and Description.

Change A9A1Q1 second entry to A9A1Q1MP1.

Change A9A1Q2 second entry to A9A1Q2MP1.

Change A9A1R7 Description, second line, to read: "(FACTORY SELECTED PART, TYPICAL VALUE SHOWN)."

Delete second A9A1R7 entry.

Change A9A2C2 Description, second line, to read: "(FACTORY SELECTED PART, TYPICAL VALUE SHOWN)."

Delete second A9A2C2 entry.

Change A9A2C1 to A9A2C1* :0160-2256 (Check Digit = 2): C: FXD CER 9.IPF +- .25 PF 500VDCW (FACTORY SELECTED PART. TYPICAL VALUE SHOWN); 28480; 0160-2256.

Add after A9A2CR6: A9A2MP1, A9A2MP2, A9A2MP3, and A9A2MP4 as follows:

A9A2MP1, HP Part Number 0380-0810, Qty 2, Description; STANDOFF: 0.437" LG, Mfr Code 01255, Mfr Part Number 1530B7/16-11.

A9A2MP2, HP Part Number 08553-0026, Qty 2, Description; SHIELD COVER: FIRST MIXER, Mfr Code 28480, Mfr Part Number 08553-0026.

A9A2MP3, HP Part Number 08553-0027, Qty 2, Description; INSULATOR: FIRST MIXER, Mfr Code 28480, Mfr Part Number 08553-0027.

A9A2MP4, HP Part Number 08553-0029, Qty 1, Description; SHIELD CAN: FIRST MIXER, Mfr Code 28480, Mfr Part Number 08553-0029.

Delete second, third, fourth, fifth, and sixth A9A2 entries.

ERRATA (Cont'd)

Page 6-10, Table 6-3 (Cont'd):

Add after A9A3L3: A9A3MP1, A9A3MP2, A9A3MP3, A9A3MP3, A9A3MP4, A9A3MP5, A9A3MP6, and A9A3MP7 as follows:

A9A3MP1, HP Part Number 2190-0057, Qty 2, Description; WASHER: LOCK FOR #12 HDW, Mfr Code 00000, Mfr Part Number OBD.

A9A3MP2, HP Part Number 0590-0060, Qty 1, Description; NUT: HEX 12-32 UNEF-2B, Mfr Code 01121, Mfr Part Number M-6377., A9A3MP3, HP Part Number 0380-0810, Description; STANDOFF: 0.437" LG, Mfr Code, 01255, Mfr Part Number 1530B7/16-11.

A9A3MP4, HP Part Number 08553-0025, Description; SHIELD CAN: 200 MHz FILTER, Mfr Code 28480, Mfr Part Number 08553-0025.

A9A3MP5, HP Part Number 08553-0026, Description; SHIELD COVER: FIRST MIXER, Mfr Code 28480, Mfr Part Number 08553-0026.

A9A3MP6, HP Part Number 08553-0027, Description; INSULATOR: FIRST MIXER, Mfr Code 28480, Mfr Part Number 08553-0027.

A9A3MP7, HP Part Number 08553-0028, Qty 1, Description; GROUND BRACKET: 200 MHz FILTER, Mfr Code 28480, Mfr Part Number 08553-0028.

Delete second, third, fourth, and fifth A9A3 entries.

Page 6-11, Table 6-3:

Delete first, second, third, and fourth A9A3 entries.

Change A10A1L4 Description, second line, to read: "(FACTORY SELECTED PART, TYPICAL VALUE SHOWN)."

Delete second A10A1L4 entry.

Page 6-12, Table 6-3:

Delete first All entry.

Change second All entry to A11MP1.

Change third All entry to A11MP2.

Change fourth All entry to A11MP3.

Page 6-13, Table 6-3:

Change entry for CR1 to: 1902-1291, 1, DIODE BREAKDOWN: 5.IV, 28480, 1902-1291.

Change second DS1 entry to DS1MP1.

Change third DS1 entry to DS1MP2.

Delete second J1 entry.

Delete second RI entry.

Change second R2 entry to R2MP1.

Change second R3 entry to R3MP1.

Delete second S1 entry.

Change second W1 entry to W1MP.

Change third W1 entry to W1MP2.

Change second W2 entry to W2MP1.

Change third W2 entry to W2MP2.

Change second W3 entry to W3MP1.

Change third W3 entry to W3MP2.

ERRATA (Cont'd)

Page 6-13, Table 6-3 (Cont'd):

- Change second W4 entry to W4MP1.
- Change third W4 entry to W4MP2.
- Change second W5 entry to W5MP1.
- Change third W5 entry to W5MP2.
- Change second W6 entry to W6MP1.
- Change third W6 entry to W6MP2.
- Change fourth W6 entry to W6MP3.
- Change second W7 entry to W7MP1.
- Change third W7 entry to W7MP2.
- Change second W8 entry to W8MP1.
- Change second W9 entry to W9MP1.
- Change second W10 entry to W10MP1.
- Change third W10 entry to W10MP2.
- Change second W11 entry to W11MP1.
- Change third W11 entry to W11MP2.
- Change second W12 entry to W12MP1.
- Change second W13 entry to W13MP1.
- Change second W14 entry to W14MP1.

Page 6-14. Table 6-3:

- Change second W15 entry to W15MP1.
- Change second W16 entry to W16MP1.

Page 6-15, Table 6-3:

- Delete 24. 0855340103, 1, WINDOW: SLIDING-BLACK, 28480.08553-40103.
- Delete 25,08553-40102, 1, WINDOW: STATIONARY-BLACK, 28480.08553-40102.
- Delete 39.08553-20114, 1, EXTRUSION-LIGHT GRAY, 28480,08553-20114.
- Delete 43, 08553-00106, 1, PANEL: FRONT-LIGHT GRAY, 28480.08553-00106.
- Delete 54,08553-20113, 1, PLATE: CONNECTOR-BLACK, 28480.08553-20113.

Page 8-3, Paragraph 8-9:

Add the following:

WARNING

Instrument power should be OFF during insertion or removal of extender boards. If power is ON, dangerous voltages may be contacted

Page 8-24, Figure 8-22, SERVICE SHEET 2:

Replace Figure 8-22 with Figure 8-22 of this Manual Changes Supplement.

Page 8-26, Figure 8-23:

- Change 957 wire leading from junction of R15 and R: 6 to 4 wire.
- Change interconnection information to read: TO SS-2 (3 of 3) and SS-I 1.
- Change CR1 to CR2 and CR2 to CR1.
- Interchange resistors R16 and R I 5. '

ERRATA (Cont'd)

Page 8-27, Figure 8-23 (Sheet 3):

In upper left-hand corner of wiring diagram, change CR5 to CR3.

In lower right-hand corner of wiring diagram, wire to IF Section color-coded "927" should be color-coded "917".

Page 8-29, Figure 8-24, SERVICE SHEET 3:

Replace Figure 8-24 with Figure 8-24 of this Manual Change Supplement.

Page 8-31, Figure 8-31, SERVICE SHEET 4:

Change A9A2C to A9A2C1 * 9.1pF.

Page 8-33, Figure 8-32:

Replace Figure 8-32 with Figure 8-32 of this Manual Change Supplement.

Page 8-33, Figure 8-33, SERVICE SHEET 5:

Replace Figure 8-33 with Figure 8-33 supplied in this supplement.

Change C39, 3.3, to C39*, 16 pF.

Page 8-35, Figure 8-34:

Reverse positions of CR9 and CR10: reverse positions of CR11 and CR12.

Page 8-35, Figure 8-36:

In Search Oscillator Amplifier circuit, change reference designation Q2 to Q3; change Q3 to Q2.

Add after APC BOARD ASSY A6A1: (08553-6060).

Page 8-37, Figure 8-38:

Change value of A8A1R35 to 909K.

Page 8-38, Paragraph 7:

Change (R3) in first line to (R2).

Page 8-39, Figure 8-42:

Reverse polarity of ASA1C4.

Change value of ASA1R6 to 909K.

Change the value of A4R6 to 9090.

Change the value of A4R7 to 2K.

Page 8-41, SERVICE SHEET 9, Figure 8-44:

Change the L3 reference designator nearest the A10A2 Second Mixer to LS.

Page 8-45, Figure 8-48:

On S2-5R wafer layout diagram, change 93 wire at 5 1/2 position to 4 wire.

Change S2-R5 switch contact schematic as shown in partial schematic in this Manual Change Supplement.

CHANGE 1

Page 6-2, Table 6-3:

Change A1 second entry, HP Part Number 08553-00109, to HP Part Number 08553-00134.

Change A2 second entry, HP Part Number 08553-00111, to HP Part Number 08553-00135.

Change A3 second entry, HP Part Number 08553-0014, to HP Part Number 08553-00133.

CHANGE 2

Page 6-8, Table 6-3:

Change A7A1R24 to HP Part Number 0698-3438, R: FXD 147 OHM 1% 1/8W FACTORY SELECTED PART, 28480, 0698-3438.

Page 8-33, Figure 8-33, SERVICE SHEET 5:

Change A7A1R24 to A7A1R24*, 147.

CHANGE 3

Page 6-2, Table 6-3:

Change entry for A2R15 to: HP Part Number 0698-4487, Qty 1, Description: R: FXD MET FLM 25.5K OHM 1% 1/8W, Mfr Code 28480, Mfr Part Number 06984487.

Page 8-26, SERVICE SHEET 2, Figure 8-23:

Change the value of R15 to 25.5K.

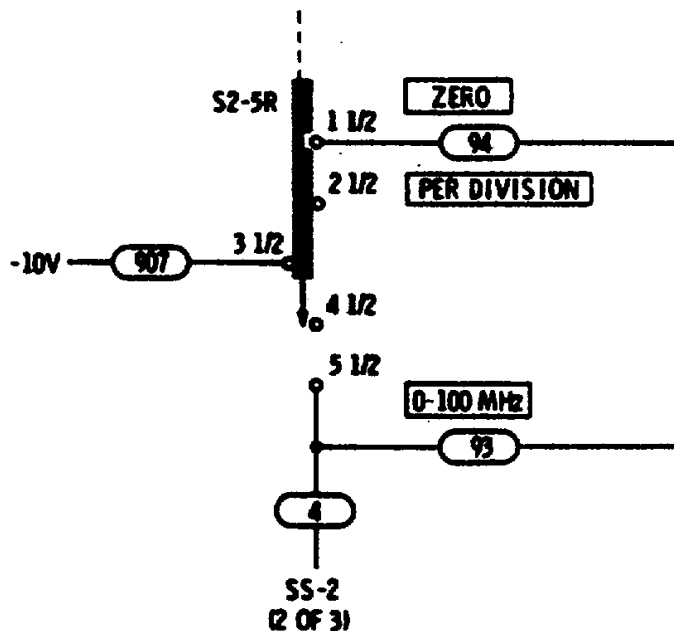

P/O Figure 8-48. Bandwidth Control Circuits for IF Section (ERRATA)

CHANGE 4

Page 6-4, Table 6-3:

Change entry for A5A1R32 to: 2100-1910, R: VAR FLM 100K OHM 20% 3/4 W (FACTORY SELECTED PART, TYPICAL VALUE SHOWN), 28480, 2100-1910.

Page 6-7, Table 6-3:

Change the entry for A7A1Q1 to: 1854-0546, 5, TSTR: S1 NPN. 28480, 18540546.
 Change the entries for A7A1Q2, 3, and 5 to: 1854-0546, TSTR: S1 NPN, 28480, 18540546.

CHANGE 4 (Cont'd)

Page 6-11, Table 6-3:

Change entry for A10A1Q2 to: 1854-0546, TSTR: S1 NPN. 28480,1854-0546.

Page 8-33, Figure 8-33, SERVICE SHEET 5:

Change the HP Part Number of A7A1Q1. 2, 3, and 5 to 1854-0546.

Page 8-39, Figure 8-42, SERVICE SHEET 8:

Change the value of A5A1 R3* to 100K.

Page 8-41, Figure 8-45. SERVICE SHEET 9:

Change the HP Part Number of A10A1Q2 to 1854-0546.

CHANGE 5

Page 6-6, Table 6-3:

Change entry for A6A1Q7 to: 1854-0019, 2, TSTR: S1 NPN, 28480, 1854-0019.

Page 6-9, Table 6-3:

Change HP Part Number and Mfr. Part Number of A8A1Q2 and A8A1Q3 to 1854-0023.

Page 6-10, Table 6-3:

Change the entry for A9A1R1 to: 0757-0798, 2, R: FXD MET FLM 110 OHM 1% I/2 W, 28480, 0757-0798.

Change the entry for A9A1R4 to: 0757-0798, R: FXD MET FLM 110 OHM 1% 1/2W, 28480,0757-0798.

Page 8-31, Figure 8-31, SERVICE SHEET 4:

Change the value of A9A1 RI and A9A1 R4 to 110 ohms.

Page 8-35, Figure 8-36, SERVICE SHEET 6:

Change HP part number of A6A1Q7 to 1854-0019.

Page 8-37, Figure 8-38, SERVICE SHEET 7:

Change HP part number of A8A1Q2 and A8A1Q3 to 1854-0023.

CHANGE 6

Page 6-3, Table 6-3:

Change entries for A5A1CR10 through ASA1CR20 to: 1901-0376, DIODE: SILICON 35V, 01973, DE131.

Page 6-9, Table 6-3:

Change entries for A9A1C2 and A9A1C7 to: 0160-0945, C: FXD MICA 910PF 5% 100 VDCW, 28480, 016040945.

Page 6-10, Table 6-3:

Change entries for A9A1CR1 and A9A1CR2 to: 1902-905, DIODE: BREAKDOWN 5.60V 5%, 01691, LVA56A.

Change entries for A9A1Q1 and A9A1Q2 to: 1854-0378, TSTR: S1 NPN, 04713, 2N5109.

Change entries for A9A1R1 and A9A1R4 to: 0698-3334, R: FXD MET FLM 178 OHM 1% 1/8W, 28480, 0698-3334.

Page 6-16, Table 6-4:

Add 01691, TRW INC. SEMICONDUCTOR DIV., LAWNSDALE, CALIF., 90260

Add 01973, GENERAL ELECTRIC CO. SEMICONDUCTOR PRODUCT DIV., SYRACUSE, N.Y., 13201.

Page 8-31, SERVICE SHEET 4, Figure 8-31:

Change breakdown voltage of A9A1CR1 and A9A1CR2 to 5.60V.

Change HP Part Number of A9A1Q1 and A9A1Q2 to 1854-0378.

Change value of A9A1R1 and A9A1R4 to 178 ohms.

Change value of A9A1C2 and A9A1C7 to 910 pf.

CHANGE 7

Page 6-6, Table 6-3:

Change HP and Mfr. Part Number for A6A1Q7 to 1854-0547.

Page 8-35, Figure 8-36, SERVICE SHEET 6:

Change part number of A6A1Q7 to 1854-0547.

CHANGE 8

Page 6-7, Table 6-3:

Change entry for A7A1CR3 to: 1902-0625, DIODE: BREAKDOWN: 6.2V 5%, 28480,1902-0625.

Delete A7A1CR4.

Change entry for A7A1 R2 to: 06980084. R: FXD MET FLM 2.15K OHM 1% 1/8W, 28480,06984084 (FACTORY SELECTED PART, TYPICAL VALUE SHOWN).

Change entry for A7A1R4 to: 0757-0441, R: FXD MET FLM 825K OHM 1% 1/8W, 28480,0757-0441.

CHANGE 8 (Cont'd)

Page 6-8, Table 6-3:

Add A7A1 R29,0698-0082, R: FXD MET FLM 464 OHM % 1/8W, 28480, 0698-0082 (FACTORY SELECTED PART, TYPICAL VALUE SHOWN).

Page 8-33, Figure 8-32, SERVICE SHEET 5:

Replace Figure 8-32 with Figure 8-32 supplied in this supplement.

Page 8-33, Figure 8-33, SERVICE SHEET 5:

Change Figure 8-33 as shown in P/O Figure 8-33 supplied in this supplement.

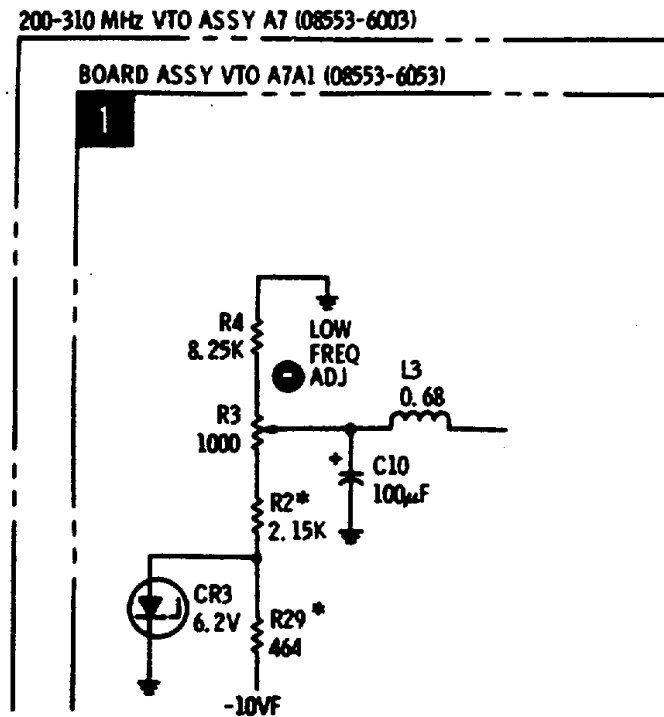

P/O Figure 8-33. 200-310 MHz Voltage-Tuned Oscillator (P/O CHANGE 8).

CHANGE 9

Page 6-10, Table 6-3:

Add A9A2L1, 91400144 (Check Digit = 0), COIL: FXD RF 4.7UH 10% Q = 45.

Add A9A2R2, 0698-7219 (Check Digit = 6), R: FXD MET FLM 196 OHM 1% .05W.

Page 8-31, Figure 8-31:

Add A9A2L1* and A9A2R2* as shown in the following partial schematic:

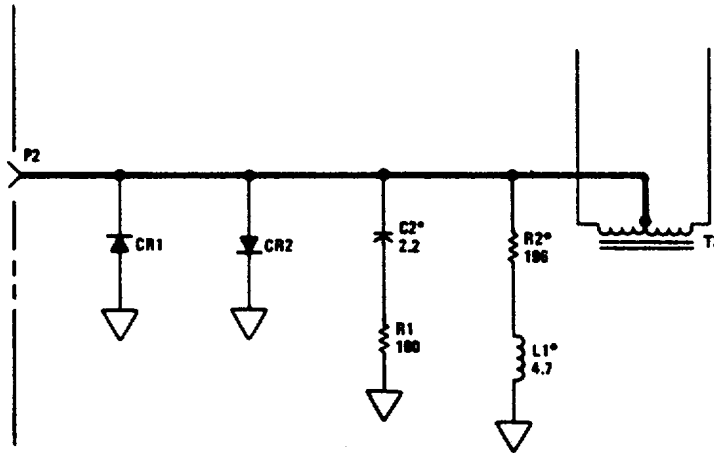

P/O Figure 8-31. First Converter and 200 MHz IF Amplifier (P/O CHANGE 9)

CHANGE 10

Page 7-6, Table 7-1:

Change A9A2L1 to A9A2L1*.

Add A9A2L2, 9140-0144 (Check Digit = 0), COIL-FXD RF 4.7 UH 10% Q = 45.

Add A9A2R4*, 0698-7219 (Check Digit = 6), R: FXD MET FLM 196 OHM 1% .05W.

Page 7-7, Figure 7-4:

Add A9A2L2 and A9A2R4 as shown in the following partial schematic.

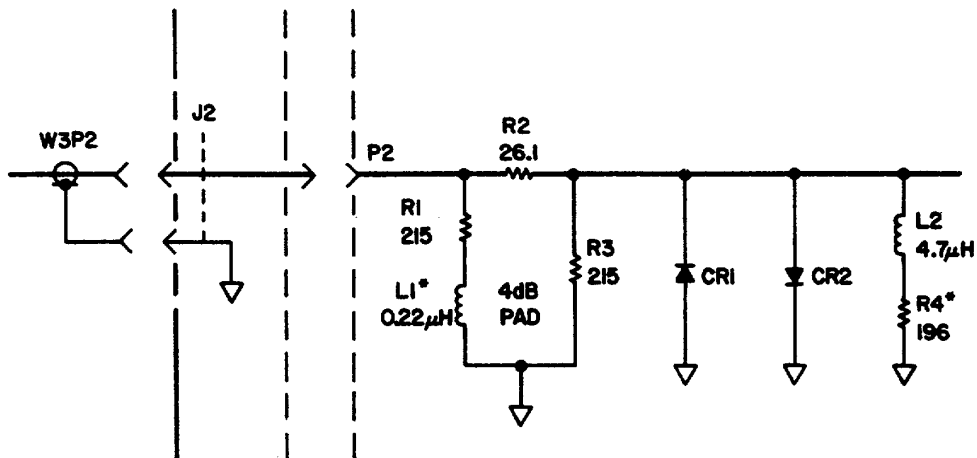

P/O Figure 7-4. H01/H02 Schematic Changes for Service Sheet 4, Figure 8-31 (P/O CHANGE 10)

4-29. Residual Responses

SPECIFICATION:

- Referred to signal level at input mixer*:
 - 200 kHz to 110 MHz: <- 100dBm
 - 20 kHz to 200 kHz: <-95 dBm.

DESCRIPTION:

Signals present on the display with no input are called residual responses. To measure residual responses, a reference is selected so that -110 dBm is easily determined. The display is searched for residual responses under the various test conditions called out.

1. Set the analyzer controls as follows:

RANGE MHz	0-110
FREQUENCY	85 MHz
FINE TUNE	Centered
BANDWIDTH	1 kHz
INPUT ATTENUATION	0 dB
SCAN WIDTH	PER DIVISION
SCAN WIDTH PER DIVISION	5 MHz
BASE LINE CLIPPER	max ccw
SCAN TIME PER DIVISION	10 SECONDS
LOG/LINEAR	LOG
LOG REF LEVEL controls	-60 dBm
TUNING STABILIZER	On
VIDEO FILTER	OFF
SCAN MODE	INT
SCAN TRIGGER	AUTO

***Signal level at input mixer - Signal level at RF INPUT - INPUT ATTENUATION.**

ERRATA

PERFORMANCE TESTS (cont'd)

4-29. Residual Responses (Cont'd)

2. Terminate the RF INPUT jack in 50 ohms.
3. Observe the display as the analyzer scans from 60 to 110 MHz. The average noise level should be less than -110 dBm and no residual responses should occur. Figure 4-13 represents a scan with no residual response, and with the average noise level indicated.

Residual Responses 60-110 MHz:

<-110 dBm _____

4. Set FREQUENCY to 35 MHz and observe the display as the analyzer scans from 10 to 60 MHz. The average noise level should be less than -110 dBm and no residual responses occur. Figure 4-13. Residual Response Tat should occur.

Residual Responses 10-60 MHz:

<-110 dBm _____

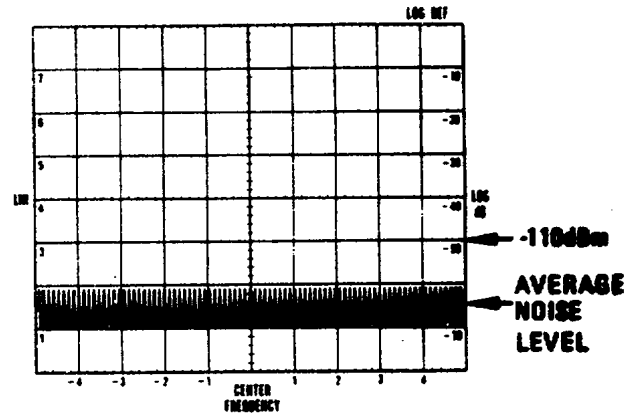

Figure 4-13. Residual Response Test

5. To check the analyzer from 1 MHz to 10 MHz, make the following control settings:

FREQUENCY 5 MHz
 SCAN WIDTH PER DIVISION 1 MF
 SCAN TIME PER DIVISION 2 SECOND

6. Observe the display for residual responses:

Residual Responses 1 - 10 MHz:

<-110 dBm _____

7. To check the analyzer from 200 kHz to 1 MHz, make the following control settings:

FREQUENCY Local Oscillator signal appears at left hand edge of graticule
 SCAN WIDTH PER DIVISION 0.1 MHz
 BANDWIDTH 0.3 kHz
 SCAN TIME PER DIVISION 5 SECONDS

8. Observe the display for residual responses over the last 8 horizontal divisions:

Residual Responses 20-200 MHz:

<-110 dBm _____

9. To check the analyzer from 20 to 200 kHz, make the following control settings:

RANGE - MHz 0-11 MHz
 FREQUENCY Local Oscillator signal appears at left hand of graticule
 SCAN WIDTH PER DIVISION 20 kHz
 BANDWIDTH 0.1 kHz
 SCAN TIME PER DIVISION 5 SECOND'
 LOG REF LEVEL -50 dB

10. Observe the display for residual responses over the last nine horizontal divisions:

Residual Responses 20-200 MHz:

<-95 dBm _____

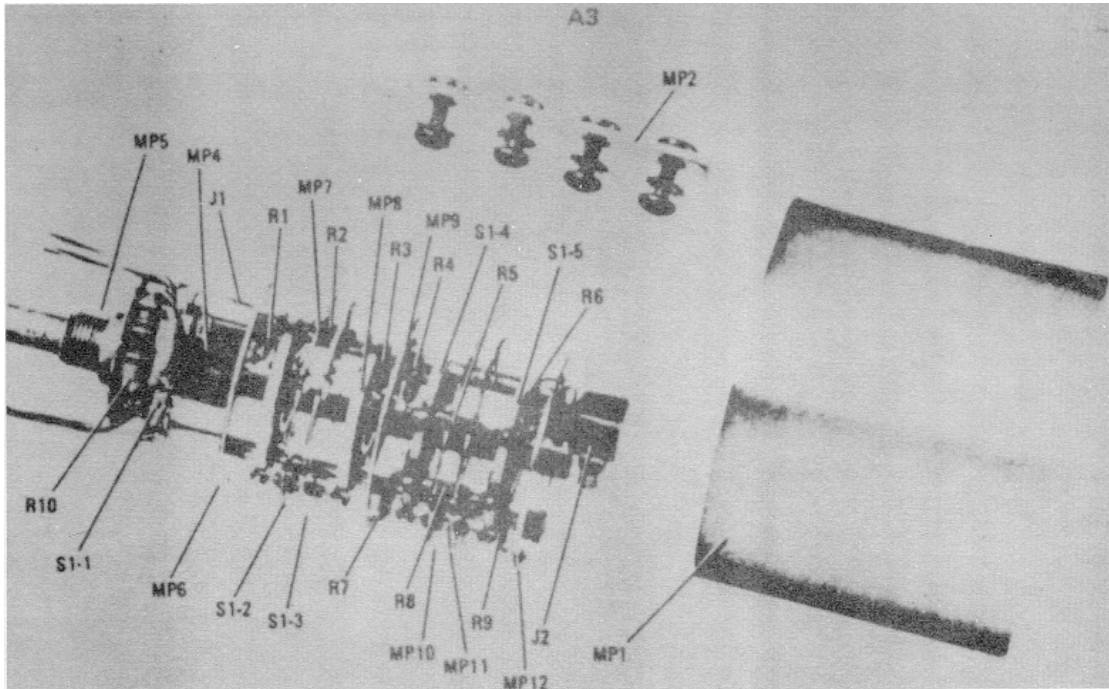

Figure 8-22. Input Attenuation Assembly A3 (08553-6021), (ERRATA)

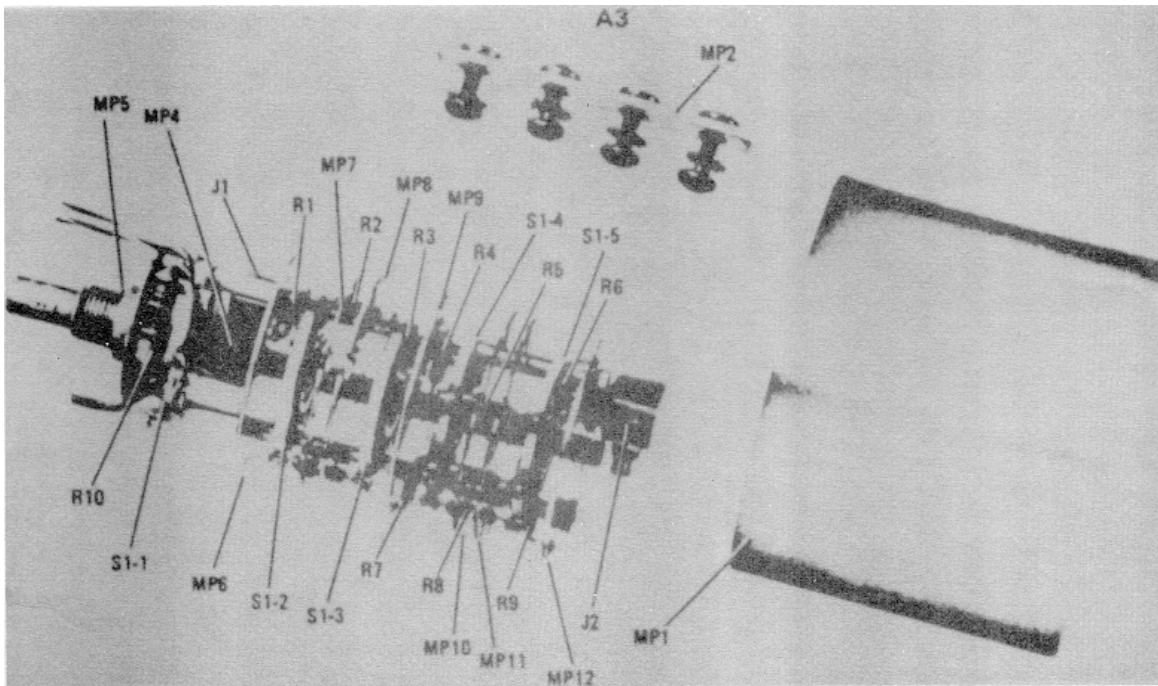

Figure 8-24. Input Attenuator Assembly A3 (08553-6021) Replaceable Parts Locations (ERRATA)

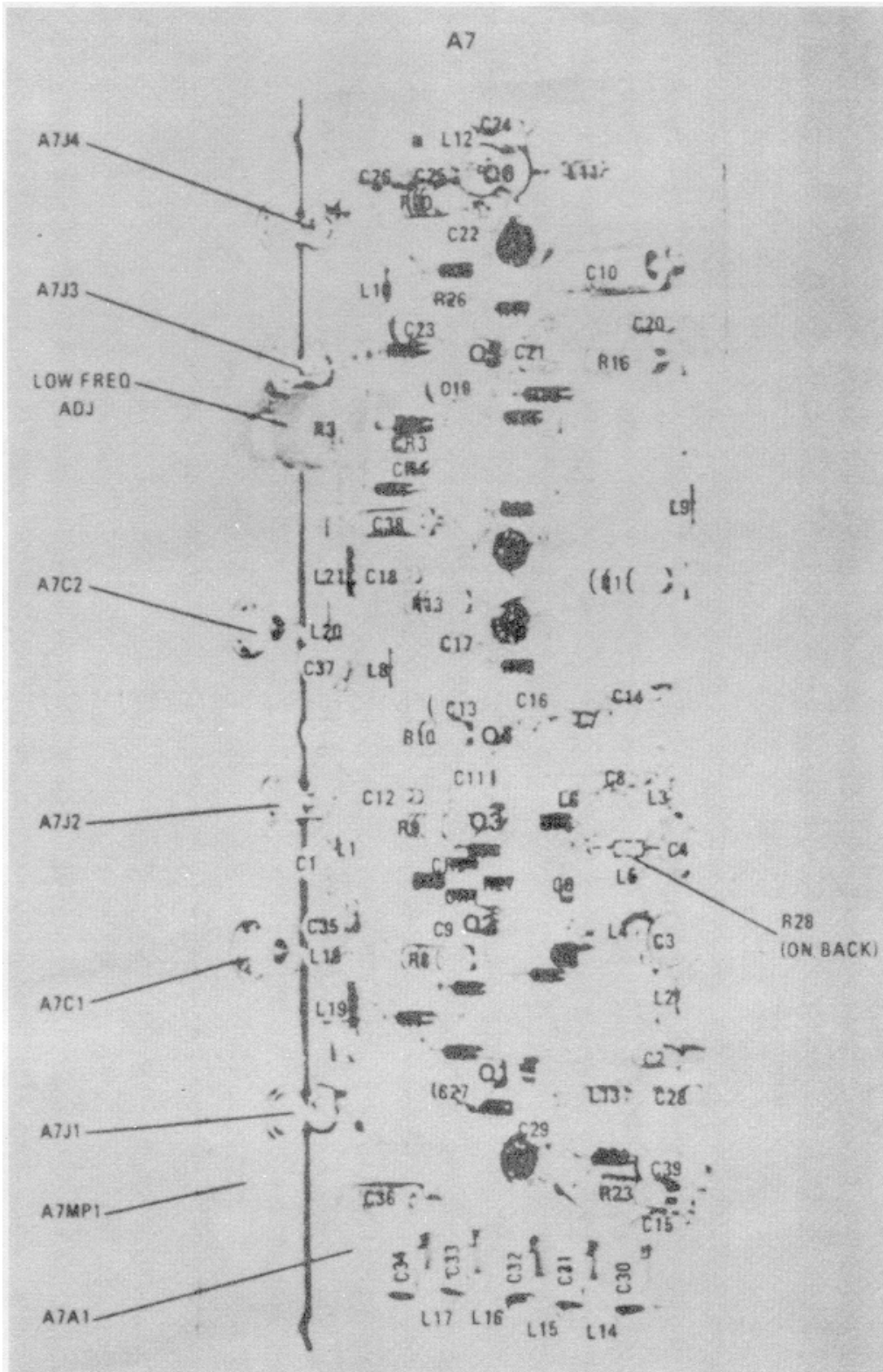

Figure 8-32. 200 - 310 MHz VTO Assembly A 7 (08553-6003) Component Locations (ERRATA)

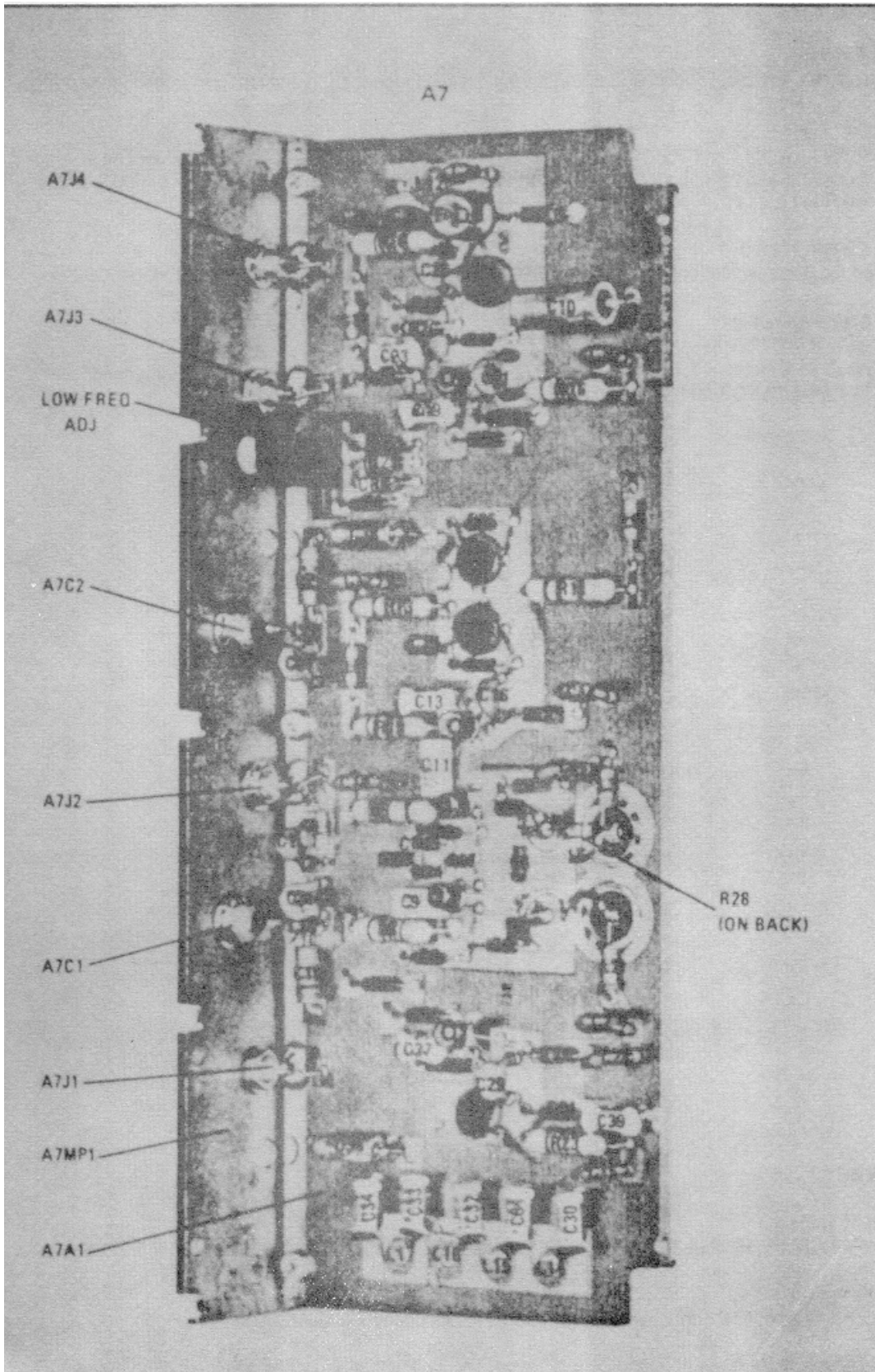

Figure 8-32. 200 - 310 MHz VTO Assembly A7 (08553-6003) Component Locations (CHANGE 8)

CHANGE 11

Page 6-3, Table 6-3:

Change ASA1CR1 to HP Part No. 1902-0785, Check Digit 3, DIODE-ZNR 1N936 9V 5% DO-7 PD=.5W.

Page 6-4, Table 6-3:

Change A5A1R14 to HP Part No. 0812-0029, Check Digit 6, RESISTOR 7.1K 5% 3W PW TC-0+-20.

Change A5A1R32* and A5A1R38* to HP Part No. 2100-3355, Check Digit 0, RESISTOR-TRMR 100K 10% C S11

ADJ I-TRN.

Page 6-13, Table 6-3:

Add R6, HP Part No. 0698-7252, Check Digit 7, RESISTOR 4.64K 1% .05W F TC-0+-100.

Page 8-39, Figure 8-42:

Change A5A1CR1 to 9V.

Change A5A1R14 to 7.1K.

Add R6 to RANGE MHz switch circuit as shown in partial schematic below:

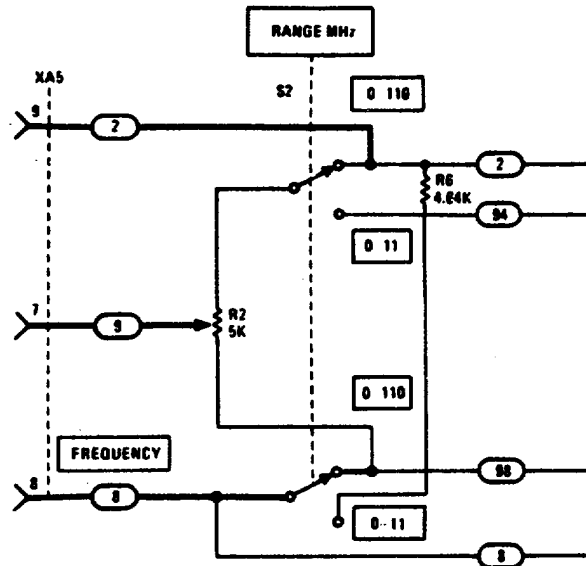

P/O Figure 8-42. First LO Tuning Voltage, Marker Generator, and Frequency Range Control Circuits (CHANGE 11)

CHANGE 12

Page 6-5, Table 6-3:

Add A5A1R68, HP Part No. 0698-7336, Check Digit 8, RESISTOR 416.25% .125W F TC-00+-100.

Page 8-39, Figure 8-42:

Add A5A1R68, 416 ohms, in series with A5A1R13 TUNING RANGE ADJ.

ERRATA

4-12. FRONT PANEL CHECK PROCEDURE

4-13. Preset Adjustments

CAUTION

Before placing the system in operation, ensure that the operating voltage indicated in the power module window agrees with the line voltage being used.

4-14. With the proper operating voltage indicated in the power module window and the ac power cord installed, perform the following steps:

- a. Set INTENSITY fully CCW.
- b. Depress STD. pushbutton and set PERSISTENCE fully CCW.
- c. Turn LINE switch ON. The CRT screen should illuminate after a few seconds.
- d. While the instrument is warming up, set the controls as follows:

RANGE MHz.....	0 - 110
FREQUENCY FINE TUNE	Mid-range (5 turns from stop)
BANDWIDTH	300 kHz
SCAN WIDTH	0-100 MHz
SCAN WIDTH PER DIVISION.....	5 MHz
INPUT ATTENUATION.....	20 dB
TUNING STABILIZER	On
BASELINE CLIPPER	Fully CCW
SCAN TIME PER DIVISION	5 MILLISECONDS
LOG REF LEVEL	- 10 dBm
LOG REF LEVEL Vernier	Fully CCW
LOG/LINEAR (8552A).....	LOG
2 dB LOG - 10 dB LOG - LINEAR (8552B).....	10 dB LOG
VIDEO FILTER	10 kHz
SCAN MODE	INT
SCAN TRIGGER.....	AUTO

- e. Turn FOCUS to approximately 1 o'clock.
- f. Turn INTENSITY clockwise until baseline trace appears on CRT screen.
- g. Tune FREQUENCY to 0. Set SCAN WIDTH to PER DIVISION. (The UNCAL light will go out.)
The LO feedthrough signal should appear near the center of the screen.
- h. Adjust FOCUS and INTENSITY for a sharp trace.
Connect CAL OUTPUT to RF INPUT using a BNC-to-BNC cable. Set FREQUENCY to 45 MHz.

4-15. Display Section Adjustments

- b. Set IF section LOG REF LEVEL fully CCW and SCAN TIME PER DIVISION to 10 SECONDS.
Adjust display section FOCUS and ASTIG for the smallest round dot possible.

ERRATA

- c. Reset SCAN TIME PER DIVISION to 5 MILLISECONDS and adjust TRACE ALIGN so that the horizontal base line of the CRT trace is exactly parallel to the horizontal graticule lines.

4-16. IF Section Adjustments

- a. Adjust HORIZONTAL POSITION to center trace on CRT. Turn LOG REF LEVEL fully CCW. Then adjust VERTICAL POSITION so that the trace lies on or as close as possible to the center horizontal graticule line. Adjust HORIZONTAL POSITION to center the trace. Then adjust HORIZONTAL GAIN until trace is exactly 10 divisions wide.
- b. Adjust VERTICAL POSITION so that the horizontal base line of the CRT trace is exactly on the bottom 'horizontal graticule line of the CRT. Set LOG REF LEVEL to 0 dBm.
- c. Set SCAN WIDTH to 0-100 MHz. The display on the CRT now should be very similar to that shown in Figure 4-1. (The amplitudes of the signals may vary from those pictured.) d. Note the inverted marker below the bottom graticule line. This marker indicates the display center frequency of the ZERO and SCAN WIDTH PER DIVISION tuning modes. Adjust the FREQUENCY control to place this marker exactly under the signal two divisions from the left of center.
- e. This signal is the 30 MHz calibrator signal. Tune the marker carefully to null the signal.

NOTE

The other signals on the display are the 'zero frequency' First LO feed-through and the 60 MHz and 90 MHz harmonics of the calibrator signal.

- f. Set SCAN WIDTH PER DIVISION to .05 MHz and BANDWIDTH to 10 kHz.
- g. Switch the red SCAN WIDTH control to PER DIVISION. The BANDWIDTH, SCAN WIDTH PER DIVISION, and center frequency are now those selected in steps e and f. (The marker makes it easy to select any signal in 0100 MHz scan and to expand the display about that signal.)
- h. Adjust FREQUENCY tuning to center 30 MHz calibrator signal, if necessary. Then reduce SCAN WIDTH PER DIVISION to 10 kHz. Use FINE TUNE to center the signal on the display. (The First LO of the analyzer is automatically phase-locked to a crystal oscillator reference for the blue color-coded SCAN WIDTH positions (20 kHz or less), since the TUNING STABILIZER is turned on. Therefore, the FREQUENCY control, which tunes the First LO, should not be used to tune the analyzer; the frequency would tune in 100 kHz steps.)
- i. Set LOG REF LEVEL to 30 dBm.
- j. Adjust VERTICAL GAIN so that signal amplitude is exactly on the LOG REF (top) graticule line of the CRT.
- k. Set LOG/LINEAR switch to LINEAR. Set LINEAR SENSITIVITY to 1 mV/div (1 mV x 1). Since the 30 dBm calibrator output is 7.1 mV (across 50 ohms), the CRT deflection should be 7.1 divisions.
- l. Adjust AMPL CAL on 8553B for a 7.1 division CRT deflection, if necessary.
- m. Repeat steps i through l until no further adjustment is necessary.

ERRATA

- n. Adjust the LOG REF LEVEL controls so that the maximum signal amplitude is exactly on the -70 db graticule line. Rotate LOG REF LEVEL control seven steps in the clockwise direction. The amplitude of the signal should increase in increments of one division per 10-dB step. (See Figure 4-2.) Adjust VERTICAL GAIN to place maximum signal amplitude exactly on LOG REF (top) graticule line (Figure 4-2).
- p. Repeat steps n and o to obtain optimum adjustment of VERTICAL GAIN (increments as close as possible to one division per 10-dB step). Only slight readjustment of the VERTICAL GAIN should be necessary.

4.17. AMPL CAL Check for Linear Sensitivity Accuracy

4-18. In the LINEAR display mode the vertical display is calibrated in absolute voltage. For LINEAR measurements the LIN scale factors on the left side of the CRT and the blue color-coded scales of the LINEAR SENSITIVITY controls are used. The signal voltage is the product (note lighted 'x' lamp) of the CRT deflection and the LINEAR SENSITIVITY control settings. It is usually most convenient to normalize the LINEAR SENSITIVITY vernier by setting it to 'I' (blue scale).

- a. Set the LOG/LINEAR switch to LINEAR. Set LINEAR SENSITIVITY to 1 mV/div. Since the 30 dBm calibrator output is 7.1 mV (across 50 ohms), the CRT deflection should be 7.1 divisions.
- b. Adjust AMPL CAL on 8553B for a 7.1 division CRT deflection, if necessary. (The LINEAR display is more expanded than the compressed LOG display, so adjustment of the AMPL CAL control can be made with more resolution in LINEAR without noticeable effect on the LOG calibration.

The analyzer is now calibrated for the LIN display mode.

4-19. AMPL CAL Adjustment (RF Section)

- a. Set LOG REF LEVEL to 30 dBm.
- b. Adjust AMPL CAL so that the signal amplitude (-30 dBm) is exactly on the LOG REF (top) graticule line of the CRT.

The analyzer is now calibrated for both the LOG and LIN display modes.

NOTE

If measurements will be done primarily in LINEAR mode, perform the procedures in paragraph 4-19 before those in paragraph 4-17.

4-20. Front Panel Checks

4-21. Set controls as follows:

RANGE MHz.....	0-110
SCAN WIDTH.....	0-110 MHz
SCAN WIDTH PER DIVISION.....	10 MHz
BANDWIDTH.....	10 kHz
LOG - LINEAR.....	LOG
LOG REF LEVEL.....	- 10 dBm

Perform Front Panel Checks listed in Table 4-2.

APPENDIX C

MAINTENANCE ALLOCATION

Section I. INTRODUCTION

C-1. General

This appendix provides a summary of the maintenance operations for PL-1399/U. It authorizes categories of maintenance for specific maintenance functions on repairable items and components and the tools and equipment required to perform each function. This appendix may be used as an aid in planning maintenance operations.

C-2. Maintenance Function

Maintenance functions will be limited to and defined as follows:

a. Inspect. To determine the serviceability of an item by comparing its physical, mechanical, and/or electrical characteristics with established standards through examination.

b. Test. To verify serviceability and to detect incipient failure by measuring the mechanical or electrical characteristics of an item and comparing those characteristics with prescribed standards.

c. Service. Operations required periodically to keep an item in proper operating condition, i.e., to clean (decontaminate), to preserve, to drain, to paint, or to replenish fuel, lubricants, hydraulic fluids, or compressed air supplies.

d. Adjust. To maintain, within prescribed limits, by bringing into proper or exact position, or by setting the operating characteristics to the specified parameters.

e. Align. To adjust specified variable elements of an item to bring about optimum or desired performance.

f. Calibrate. To determine and cause corrections to be made or to be adjusted on instruments or test measuring and diagnostic equipments used in precision measurement. Consists of comparisons of two instruments, one of which is a certified standard of known accuracy, to detect and adjust any discrepancy in the accuracy of the instrument being compared.

g. Install. The act of emplacing, seating, or fixing into position an item, part, module (component or assembly) in a manner to allow the proper functioning of the equipment or system.

h. Replace. The act of substituting a serviceable like type part, subassembly, or module (component or assembly) for an unserviceable counterpart.

i. Repair. The application of maintenance services (inspect, test, service, adjust, align, calibrate, replace) or other maintenance actions (welding, grinding, riveting,

straightening, facing, remachining, or resurfacing) to restore serviceability to an item by correcting specific damage, fault, malfunction, or failure in a part, subassembly, module (component or assembly), end item, or system.

j. Overhaul. That maintenance effort (service/action) necessary to restore an item to a completely serviceable/operational condition as prescribed by maintenance standards (i.e., DMWR) in appropriate technical publications. Overhaul is normally the highest degree of maintenance performed by the Army. Overhaul does not normally return an item to like new condition.

k. Rebuild. Consists of those services/actions necessary for the restoration of unserviceable equipment to a like new condition in accordance with original manufacturing standards. Rebuild is the highest degree of materiel maintenance applied to Army equipment.

The rebuild operation includes the act of returning to zero those age measurements (hours, miles, etc.) considered in classifying Army equipments/components.

C-3. Column Entries

a. Column 1, Group Number. Column 1 lists group numbers, the purpose of which is to identify components, assemblies, subassemblies, and modules with the next higher assembly.

b. Column 2, Component/Assembly. Column 2 contains the noun names of components, assemblies, subassemblies, and modules for which maintenance is authorized.

c. Column 3, Maintenance Function. Column 3 lists the functions to be performed on the item listed in column 2. When items are listed without maintenance functions, it is solely for purpose of having the group numbers in the MAC and RPSTL coincide.

d. Column 4, Maintenance Category. Column 4 specifies, by the listing of a "work time" figure in the appropriate subcolumn(s), the lowest level of maintenance authorized to perform the function listed in column 3. This figure represents the active time required to perform that maintenance function at the indicated category of maintenance. If the number or complexity of the tasks within the listed maintenance function vary at

different maintenance categories, appropriate 'work time' figures will be shown for each category. The number of task-hours specified by the "work-time" figure represents the average time required to restore an item (assembly, subassembly, component, module, end item or system) to a serviceable condition under typical field operating conditions. This time includes preparation time, troubleshooting time, and quality assurance/quality control time in addition to the time required to perform the specific tasks identified for the maintenance functions authorized in the maintenance allocation chart. Subcolumns of column 4 are as follows:

- C—Operator/Crew
- O—Organizational
- F—Direct Support
- H—General Support
- D—Depot

e. Column 5, Tools and Equipment. Column 5 specifies by code, those common tool sets (not individual tools) and special tools, test, and support equipment required to perform the designated function.

f. Column 6, Remarks. Column 6 contains an alphabetic code which leads to the remark in section IV, Remarks, which is pertinent to the item opposite the particular code.

C-4. Tool and Test Equipment Requirements (Sec. III)

a. Tool or Test Equipment Reference Code. The numbers in this column coincide with the numbers used in the tools and equipment column of the MAC. The numbers indicate the applicable tool or test equipment for the maintenance functions.

b. Maintenance Category. The codes in this column indicate the maintenance category allocated the tool or test equipment.

c. Nomenclature. This column lists the noun name and nomenclature of the tools and test equipment required to perform the maintenance functions.

d. National/NATO Stock Number. This column lists the National/NATO stock number of the specific tool or test equipment.

e. Tool Number. This column lists the manufacturer's part number of the tool followed by the Federal Supply Code for manufacturers (5-digit) in parentheses.

C-5. Remarks (Sec. IV)

a. Reference Code. This code refers to the appropriate item in section II, column 6.

b. Remarks. This column provides the required explanatory information necessary to clarify items appearing in section II.

(Next printed page is C-3)

**SECTION II MAINTENANCE ALLOCATION CHART
FOR
SPECTRUM ANALYZER RF SECTION PL-1399/U (HP8553B)**

(1) GROUP NUMBER	(2) COMPONENT ASSEMBLY	(3) MAINTENANCE FUNCTION	(4) MAINTENANCE CATEGORY					(5) TOOLS AND EQUIPMENT	(6) REMARKS
			C	O	F	H	D		
00	SPECTRUM ANALYZER RF SECTION	Inspect Test Test Service Repair Overhaul		0.3		0.5		11 1-10 0.8 1-10 1.0 2.0	A
01	VOLTAGE CONTROL ASSEMBLY A5	Test Replace Repair				0.3 0.2		6,7,10 6,7,10 0.8 6,7,10	
02	AUTOMATIC PHASE CONTROL SAMPLER AMPLIFIER CIRCUIT A6	Test Replace Repair				0.3 0.2		3,6,7,10 3,6,7,10 0.8 3,6,7,10	
03	200-310 MHz VOLTAGE TUNED OSCILLATOR ASSEMBLY A7	Test Replace Repair				0.3 0.2		2,5,10 2,5,10 0.8 2,5,10	
04	1 MHz REFERENCE ASSEMBLY	As Test Replace Repair				0.3 0.2		6,7,9,10 6,7,9,10 0.8 6,7,9,10	
05	200 MHz IF ASSEMBLY A9	Test Replace Repair				0.3 0.2		2,5,10 2,5,10 0.8 2,5,10	
06	SECOND CONVERTER ASSEMBLY A10	Test Replace Repair				0.3 0.2		2,8,10 2,8,10 0.8 2,8,10	

**SECTION III. TOOL AND TEST EQUIPMENT REQUIREMENTS
FOR
SPECTRUM ANALYZER RF SECTION PL-1399/U (HP 8553B)**

TOOL OR TEST EQUIPMENT REF CODE	MAINTENANCE CATEGORY	NOMENCLATURE	NATIONAL/NATO STOCK NUMBER	TOOL NUMBER
1	H	VARIABLE VOLTAGE TRANSFORMER -16	5960-00-235-2086	
2	H	VOLTMETER, VECTOR ME-512	6625-00-929-1897	
3	H	VOLTMETER, ELECTRONIC HE-303	6625-00-967-1504	
4	H	HF SIGNAL GENERATOR AN/GRM-50	6625-00-868-8353	
5	H	VHF SIGNAL GENERATOR AN/USM-44	6625-00-669-4031	
6	H	OSCILLOSCOPE AN/USM-281C	6625-00-106-9632	
7	H	DIGITAL VOLTMETER A/USM-451	6625-01-060-6804	
8	H	FREQUENCY COUNTER AN/USM-459	6625-01-061-8928	
9	H	POWER SUPPLY (HP 6215A)	6130-00-489-9167	
10	H	SERVICE KIT (HP 11592A)	6625-00-217-0478	
11	O	COMMON TOOLS NECESSARY TO THE PERFORMANCE OF THIS MAINTENANCE FUNCTION ARE AVAILABLE TO MAINTENANCE PERSONNEL FOR THE MAINTENANCE CATEGORY LISTED.		

SECTION IV. REMARKS
SPECTRUM ANALYZER RF SUCTION PL-1399/U (HP 8553B)

REFERENCE CODE	REMARKS
A	<p>THE RF SECTION PL-1399/U (HP 8553B) IS A PLUG-IN FOR THE IP-1216 (WP 141T) SPECTRUM ANALYZER MAINFRAME. FOR TESTING THIS PLUG-IN, THE PL-1388/U (HP 8552B) SPECTRUM ANALYZER IF SECTION IS REQUIRED.</p>

APPENDIX D

OPERATOR'S, ORGANIZATIONAL, DIRECT SUPPORT
AND GENERAL SUPPORT MAINTENANCE
REPAIR PARTS AND SPECIAL TOOLS LIST

NOTE

Refer to Section VI, Reparable Parts, for all parts required for the operation and repair of the Spectrum Analyzer RF Section PL-1399/U.

APPENDIX E
MANUAL SUPPLEMENT

The following consists of supplements that were made after publication of the manual.

E-1

H23-8553B OPERATING AND SERVICE MANUAL SUPPLEMENT**GENERAL DESCRIPTION**

The H23-8553B is a modified version of the 8553B Spectrum Analyzer RF Section. The modification consists of an extra connector on the rear panel wired to allow existing circuitry to be remotely controlled. The H23-8553B is intended for use in an 85803A as part of the 8580A Automatic Spectrum Analyzer.

The H23- modification has been designed for use in the 8580A under computer control. With the exception of the Input Attenuator switch, the front panel controls operate as shown in the 8553B Operating and Service Manual when the system MANUAL mode is selected. The Input Attenuator is not switchable in the MANUAL mode. In the system AUTO mode, all front panel controls and indicators are disabled and their functions are controlled remotely by the computer.

CIRCUIT DESCRIPTION

The H23- modification allows remote operation of the various functions in the 8553B. Figure 1 shows the connections to the added connector P7 and a short description of each connection.

REPLACEABLE PARTS

The H23- modification requires some changes to the Parts List (Tables 6-3 and 6-4) in the 8553B Operating and Service Manual. The changes are as follows:

- a. Add A3CR1, Diode: Silicon, HP Part No. 1901-0025.

- b. Change A6C26 and A6C27 to C: fxd mylar, 0.1 μ F, 5%, 200 VDCW, HP Par, No. 0170-0019.
- c. Delete A8C20.
- d. Change A8C21 to C: fxd, elect, 0.15 μ F 10%, 35 VDCW, HP Part No. 0180-2127.

SCHEMATIC DIAGRAMS

This supplement contains replacement schematic diagrams for Service Sheets 2, 3, 6, 7, and 8 in the 8553B Operating and Service Manual. These replacement schematic diagrams show the changes made for the H23- modification.

MAINTENANCE

The Performance Tests and Adjustments sections of the 8553B Operating and Service Manual also apply to the H23- modification. However, the HP 11592-60015 Extender Cable Assembly called out in the 8553B manual should NOT be used. For this purpose the 85813-60013 and 85813-60014 Extender Cables, provided as part of the 85813P Service Kit should be used. These cables are compatible with either the 85803A/85802A or 140-series oscilloscope mainframe, when testing and repair are done in the field. When used with the 140-series mainframe, it will be necessary to provide +20 Vdc from an external source. If used with the 85803A, the external power supply is not necessary.

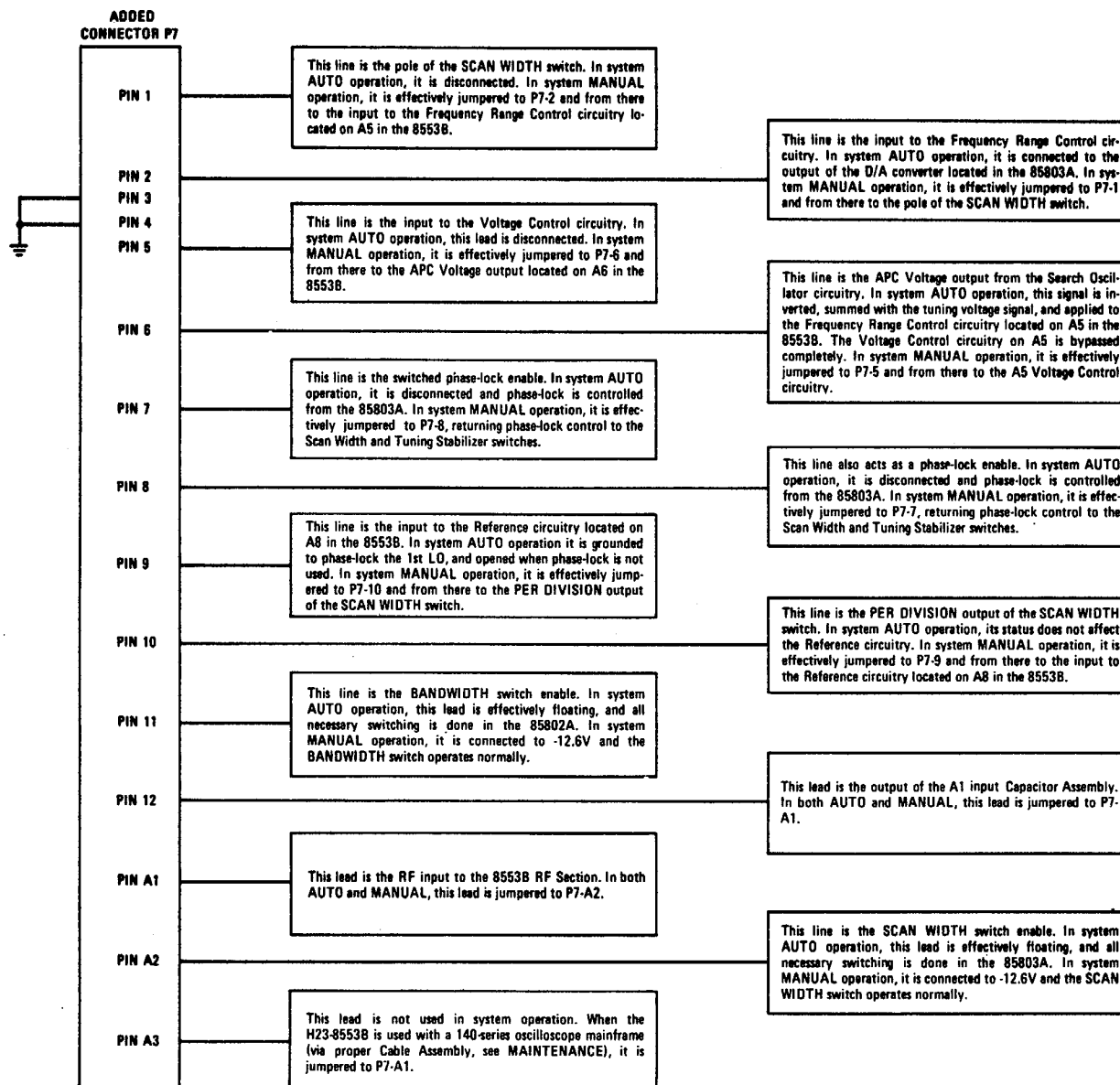

Figure 1. Connections to Added Connector P7

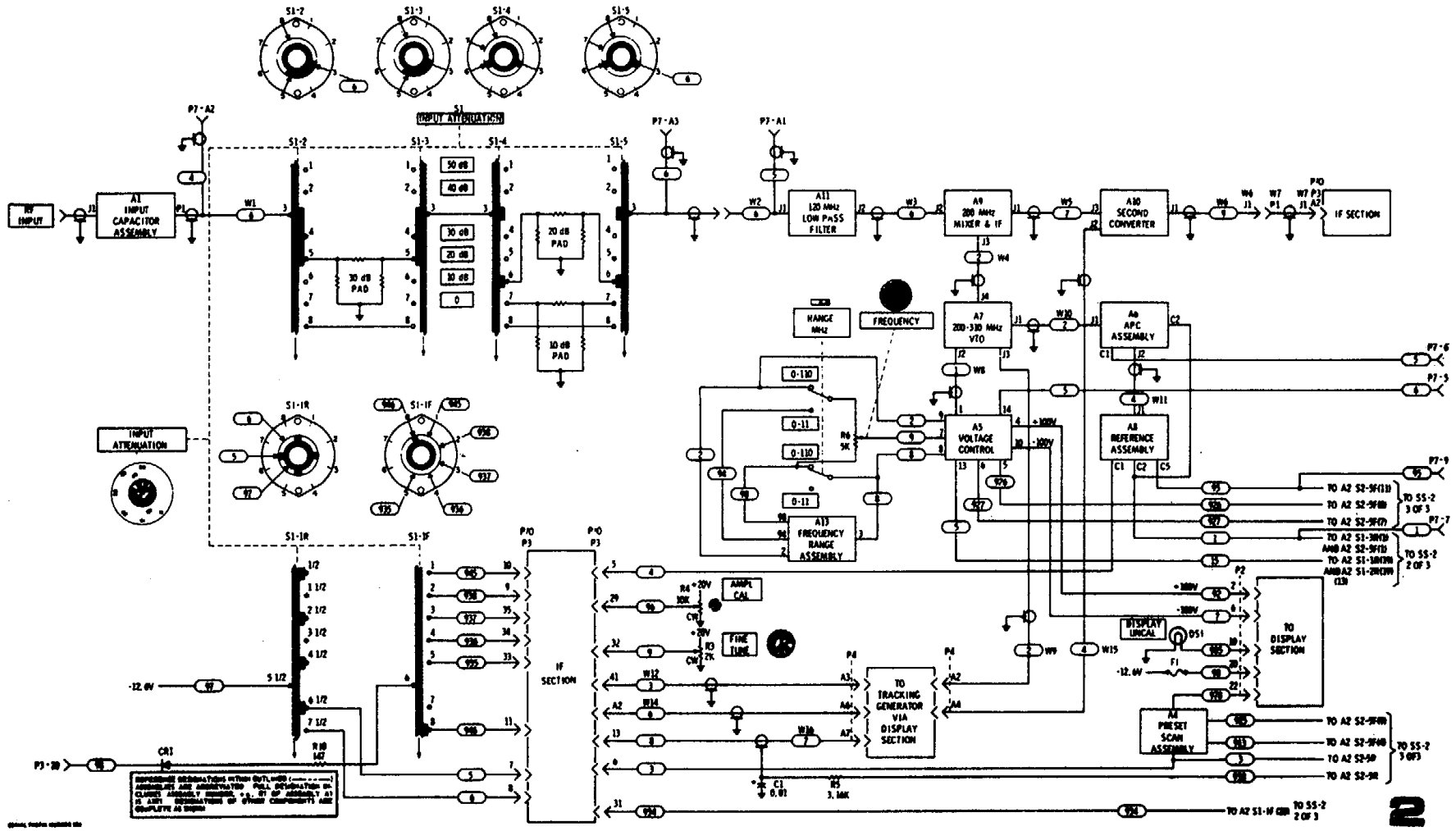

Figure 2. Overall Wiring and Switching Diagram (replacement for Service Sheet 2 (1 of 3) in 8553B Operating and Service Manual

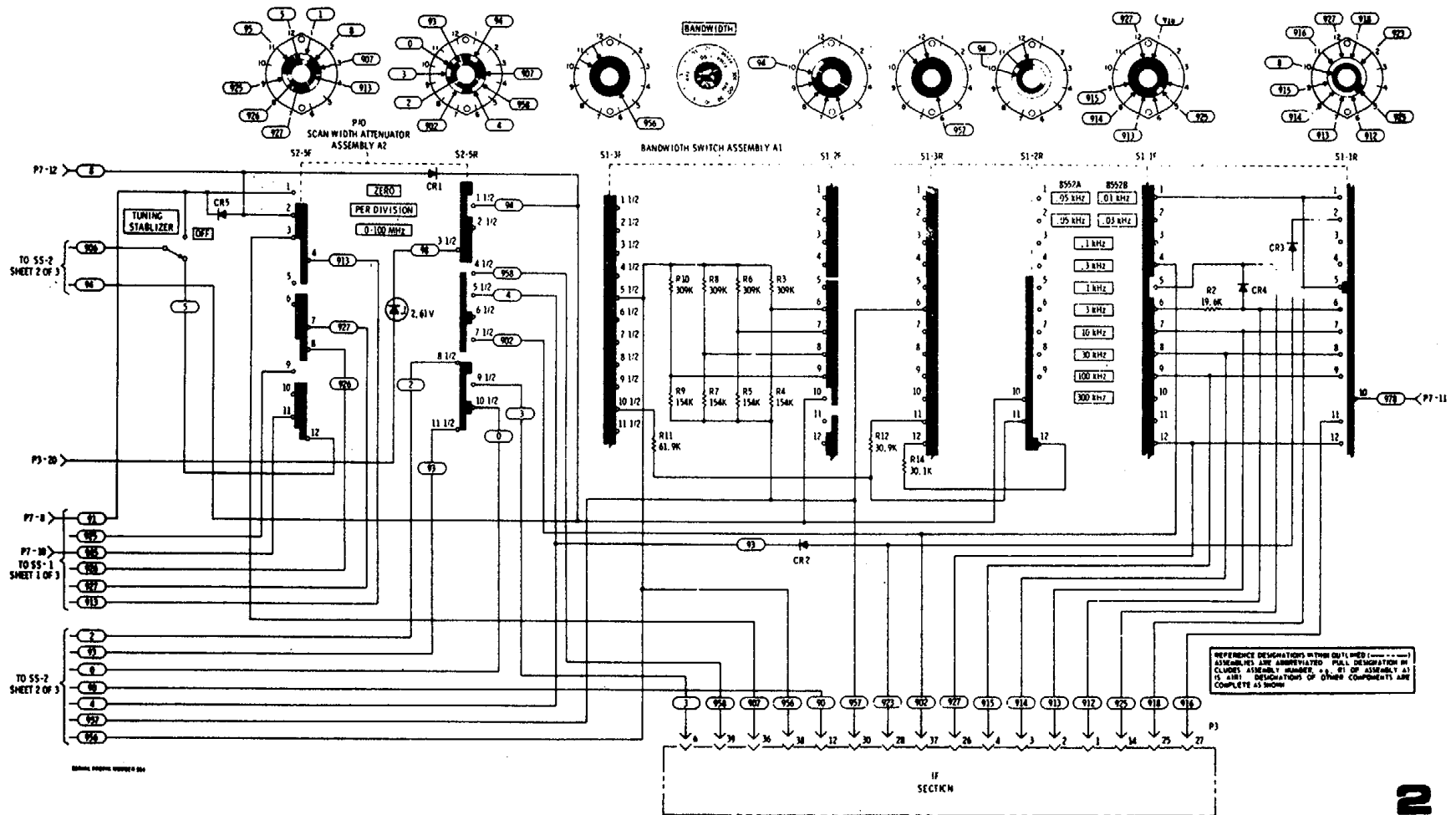

Figure 3. Overall Wiring and Switching Diagram (replacement for Service Sheet 2(3 of 3) in 8553B Operating and Service Manual)

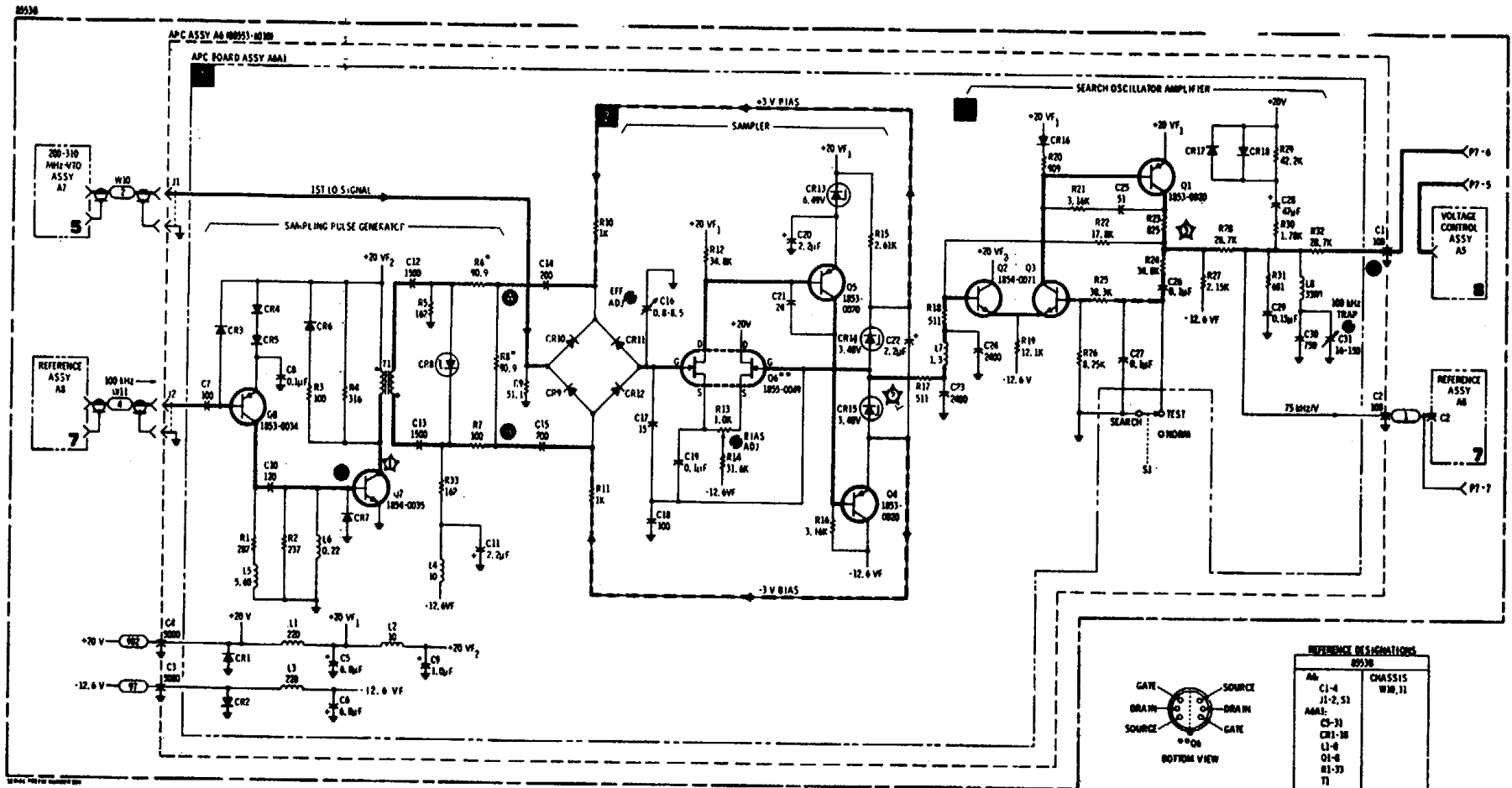

Figure 5. Automatic Phase Control and Sampler/Amplifier Circuits, Schematic Diagram (replacement for Service Sheet 6 in 8553B Operating and Service Manual)

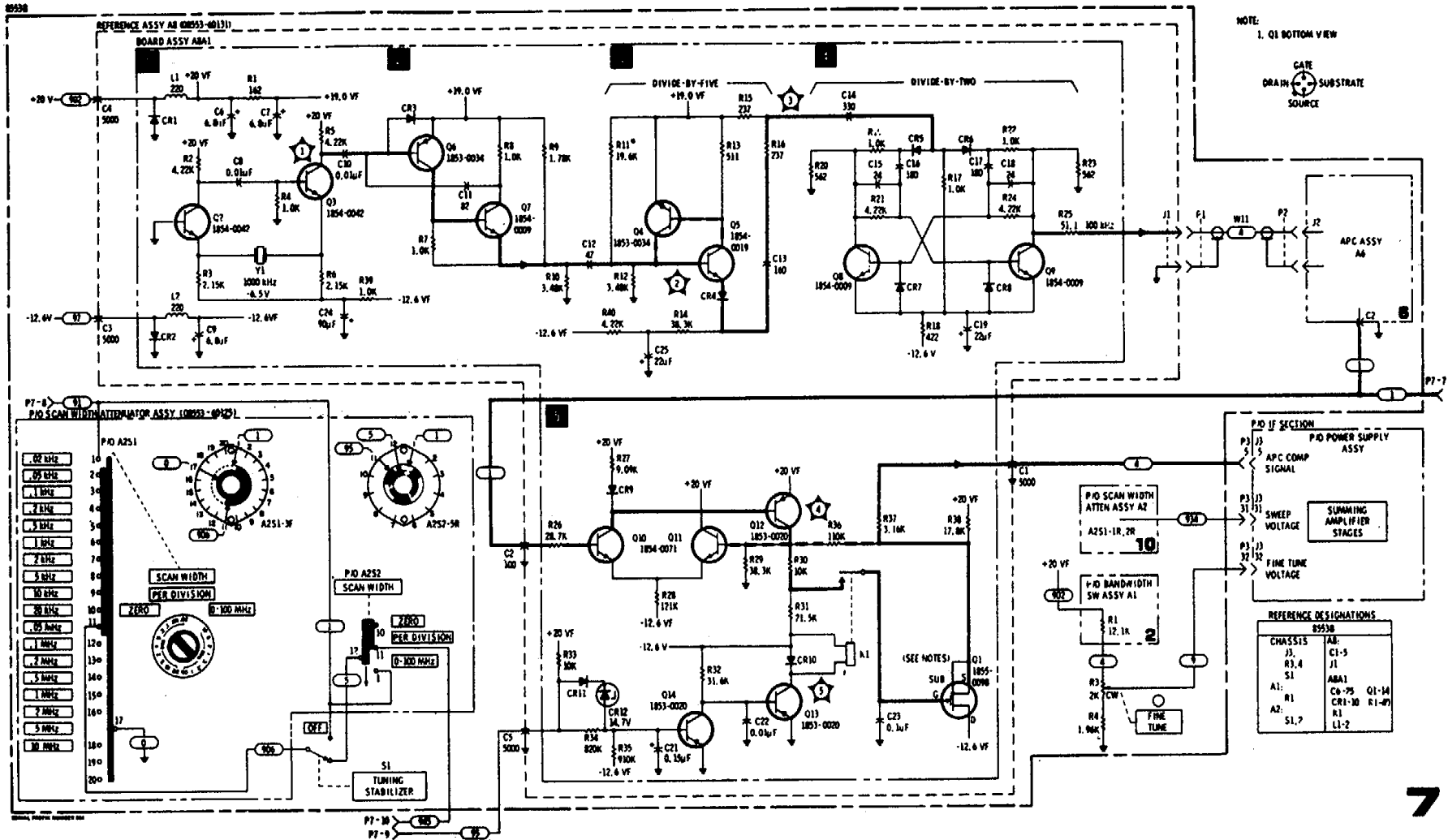

Figure 6. 1 MHz Crystal Oscillator, Frequency Divider and APC Compensation Circuits, Schematic Diagram (replacement for Service Sheet 7 in 8553B Operating and Service Manual)

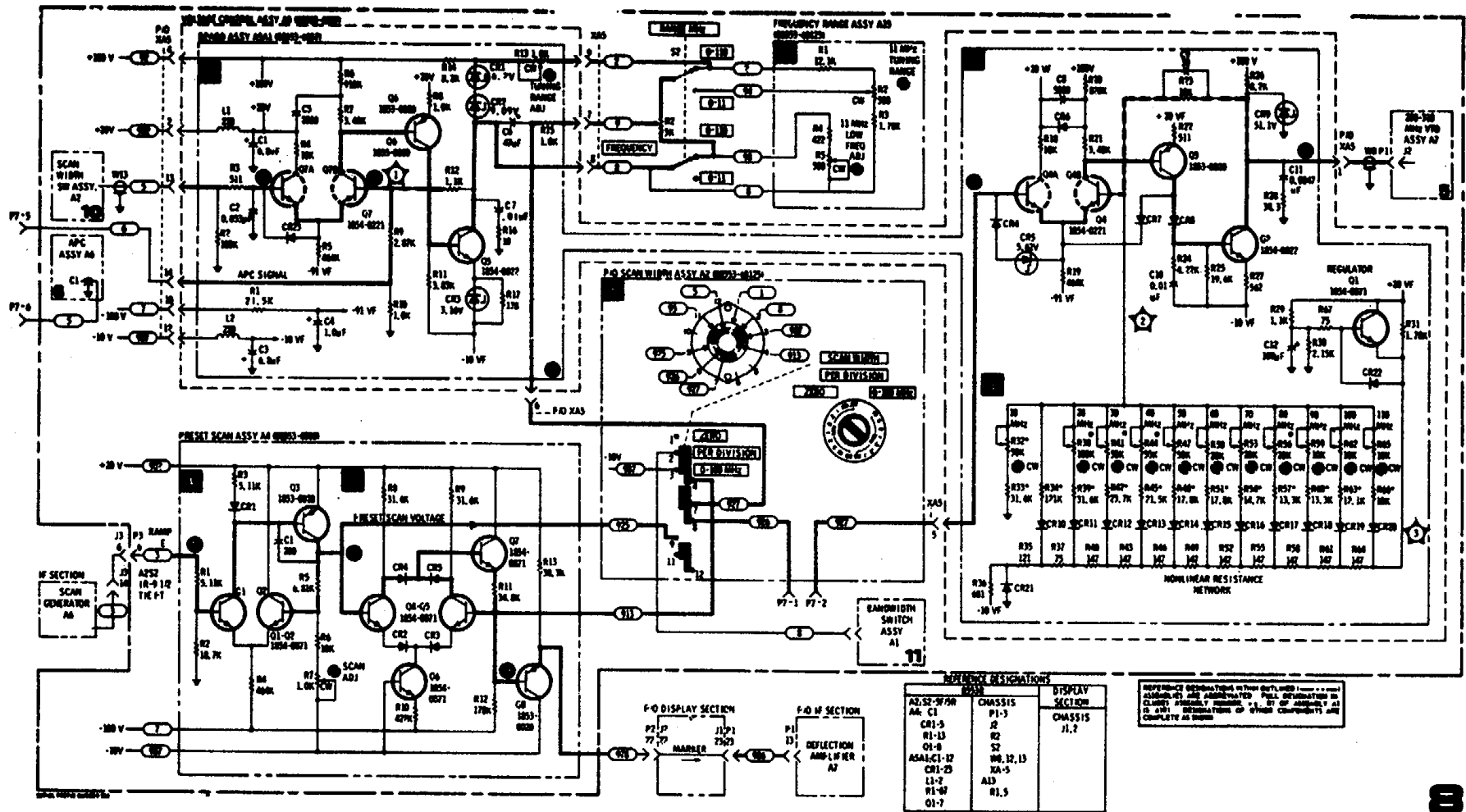

Figure 7. First LO Tuning Voltage, Marker Generator and Frequency Range Control Circuits, Schematic Diagram (replacement for Service Sheet 8 in 8553B Operating and Service Manual)

* U. S. GOVERNMENT PRINTING OFFICE : 1993 O - 342-421 (63249)

By Order of the Secretary of the Army:

Official:

ROBERT M. JOYCE
Brigadier General, United States Army
The Adjutant General

E.C. MEYER
General, United States Army
Chief of Staff

Distribution:

To be distributed in accordance with special mailing list.

PIN: 039665-000